



# ECC Report **359**

Coexistence between the radionavigation-satellite and the  
amateur services in the frequency range 1240-1300 MHz

approved 27 September 2024

## 0 EXECUTIVE SUMMARY

The frequency range 1240-1300 MHz is allocated on a primary basis to the RNSS and is used by the European Galileo system across the frequency range 1258.29-1299.21 MHz in RNSS sub-band E6 for the provisioning of radio navigation satellite services (RNSS). The frequency band 1240-1300 MHz is also allocated to the amateur service and partly to the amateur satellite service (1260-1270 MHz), both on a secondary basis in the ITU Radio Regulations. This band is further shared with primary allocations to the radiolocation (RLS), radionavigation (RNS) on a co-primary basis and with the Earth exploration-satellite service (EESS (active)) a co-secondary basis. Between 2019 and 2023, similar work within ITU-R studied the global set of RNSS systems in the range 1240-1300 MHz, including additionally the Russian Federation system GLONASS, the Chinese Beidou system and the Japanese QZSS. As a result of that work, Report ITU-R M.2513 [32] and Report M.2532 [33] were published, along with Recommendation ITU-R M.2164 [31].

With the implementation of the Galileo system in the E6 sub-band, it has become necessary to study the operating conditions for applications and operating modes in the amateur and amateur satellite services to assess their potential for interference into the terrestrial Galileo receivers and develop guidance to ensure the protection of these receivers whilst enabling continued use of this band by the amateur services and ensuring the continued long-term development of both amateur and amateur satellite services in this band.

For radio amateurs worldwide the allocation to the amateur service in the frequency band 1240-1300 MHz, known as the “23cm-band”, is an important band for both narrowband and wideband applications as an entry point for microwave frequency propagation monitoring and communication experiments. There is an established base of installed stations that have been in operation for 40 years or more.

Some cases of harmful interference caused by emissions from the stations in the Amateur Service into Radionavigation-Satellite Service (RNSS) (space-to-Earth) receivers of two Administrations are reported in this document.

The studies detailed in this report show that there is a potential for amateur station emissions in the range 1258-1300 MHz to be received in Galileo RNSS receivers at levels exceeding the receiver protection criteria defined by the Recommendation ITU-R M.1902-2 [37]. The amount of exceedance depends mainly on the power level of the amateur emissions and the separation distance. The power level of the amateur emissions may depend on the specific amateur service application and the type of station deployed. Certain characteristics of the amateur stations (e.g. antenna gain) and operation (e.g. activity factor) may influence the geographic extent of possible interference or the number of RNSS receivers that might receive signals above their protection criteria and for how long. It is noted that some studies in section 6 did not consider clutter, which is likely an added source of attenuation.

The measurement campaigns reported in section 7 provide more detail on the performance degradation of the Galileo receivers in the presence of amateur signals of various types. These campaigns provide more detail on how the receivers may be more or less susceptible depending on the nature and bandwidth of the amateur signal and where it is placed within the RNSS receiver operating band. These testing campaigns show potential interference between certain amateur applications and RNSS within the E6 band. This remains true almost for any of the considered receivers, and it was shown that the results seem almost independent from the specific GNSS receiver bandwidth. In addition, the specific receiver implementation may have some bearing on the susceptibility to interfering signals.

In order to minimise such cases of interference in the future, technical and operational measures to protect RNSS systems have been considered that can allow the amateur and amateur satellite services to continue to operate in part of the band 1258 to 1300 MHz in a way that can reduce the potential for interference into Galileo RNSS receivers. These are detailed in section 9.

## TABLE OF CONTENTS

<b>0</b>	<b>Executive summary .....</b>	<b>2</b>
<b>1</b>	<b>Introduction .....</b>	<b>7</b>
<b>2</b>	<b>AMATEUR SERVICES.....</b>	<b>8</b>
2.1	Amateur services in 1240-1300 MHz .....	8
2.1.1	Introduction .....	8
2.1.2	Characteristics of amateur signal emissions .....	8
2.1.3	IARU band plan.....	8
2.1.4	Amateur Station Categorisation .....	10
2.1.5	Typical Amateur Station Type Characteristics.....	12
2.1.6	Representative antenna heights .....	14
2.1.7	Typical Usage Patterns.....	14
2.1.8	Activity factors and operational considerations of amateur transmitting stations in the 1240-1300 MHz band .....	16
2.1.9	User density of amateur transmitting stations in the 1240-1300 MHz band.....	16
2.1.10	Impact of amateur station emissions .....	17
<b>3</b>	<b>RNSS systems.....</b>	<b>18</b>
3.1	Typical RNSS applications in the 1240-1300 MHz band.....	18
3.2	Galileo Emissions and Protection requirements.....	18
3.2.1	Galileo system description.....	18
3.2.2	Galileo E6 Signal Baseline .....	18
3.2.3	Galileo Protection requirements .....	21
<b>4</b>	<b>Scenarios for sharing evaluation .....</b>	<b>22</b>
4.1	Frequency overlap between, RNSS and amateurs .....	22
4.2	Propagation model.....	22
4.2.1	Time variability effects .....	23
4.2.2	Space variability effects .....	23
<b>5</b>	<b>Methodology.....</b>	<b>26</b>
5.1	Calculation of the interference exceedance level (IEL) .....	26
5.2	Computation of the gain of the amateur antenna station .....	26
5.3	Computation of the transmission losses.....	27
<b>6</b>	<b>Simulations.....</b>	<b>28</b>
6.1	Simulation results: minimum coupling loss studies .....	28
6.1.1	Home station 1 .....	29
6.1.2	Home station 2 .....	30
6.1.3	Permanent station.....	31
6.2	Galileo IEL extracted from the minimum coupling loss studies .....	32
6.2.1	Home station 1 .....	32
6.2.2	Home station 2.....	34
6.2.3	Permanent station.....	35
6.3	Simulation results: impact of certain amateur station emissions on a deployment simulation of a large number of co-frequency RNSS (space-to-Earth) receivers.....	37
6.3.1	Fixed home Station and fixed RNSS receiver Simulation .....	37
6.3.2	Fixed Amateur home Station and Mobile RNSS receivers.....	40
6.3.3	Permanent Amateur Station (Repeater output) and Mobile RNSS receivers.....	43
6.3.4	Summary.....	45
<b>7</b>	<b>Measurements .....</b>	<b>46</b>

<b>8</b>	<b>Results of studies .....</b>	<b>47</b>
<b>9</b>	<b>Interference Mitigation .....</b>	<b>48</b>
<b>10</b>	<b>Conclusions.....</b>	<b>49</b>
	<b>ANNEX 1: AMSS regulations and deployment in Switzerland .....</b>	<b>50</b>
	<b>ANNEX 2: Parameters of unmanned Amateur Radio Stations in Germany, Frequency Range 1240-1300 MHz.....</b>	<b>52</b>
	<b>ANNEX 3: A survey of the number of active (transmitting) amateur stations using the band 1240-1300 MHz at the busiest times in some countries within the CEPT region .....</b>	<b>56</b>
	<b>ANNEX 4: Amateur radio repeater and beacon stations using the band 1240-1300 MHz in some countries within the CEPT region-May 2020 .....</b>	<b>59</b>
	<b>ANNEX 5: Measurements made in Germany .....</b>	<b>65</b>
	<b>ANNEX 6: Measurements from EC JRC on interference event from Amateur stations to GNSS in Italy .....</b>	<b>82</b>
	<b>ANNEX 7: Study to Evaluate potential Interference Areas.....</b>	<b>91</b>
	<b>ANNEX 8: Study to Evaluate the possibility of using the bands 1293-1294 MHz or 1293.845-1294.345 MHz for amateur applications.....</b>	<b>107</b>
	<b>ANNEX 9: List of references.....</b>	<b>111</b>

## LIST OF ABBREVIATIONS

<b>Abbreviation</b>	<b>Explanation</b>
<b>ARNS</b>	Aeronautical Radionavigation Service (ITU RR)
<b>ATV</b>	Amateur television (usually analogue FM emissions)
<b>AWGN</b>	Additive white Gaussian noise
<b>BOC</b>	Binary Offset Carrier
<b>BPS</b>	Bits per second
<b>BPSK</b>	Binary phase shift keying
<b>C/NAV</b>	Commercial Navigation message (provided in E6-B signal)
<b>C/N<sub>0</sub></b>	Carrier to Noise ratio
<b>CAS</b>	Commercial Authentication Service (Galileo E6)
<b>CBOC</b>	Composite Binary Offset Carrier modulation
<b>CDMA</b>	Code Division Multiple Access
<b>cps</b>	Chips per second
<b>CRC</b>	Cyclic Redundancy Check
<b>CW</b>	Continuous wave (in amateur service also used for Morse telegraphy communication)
<b>DATV</b>	Digital Amateur TV (applying DVB-S and DVB-S2 Standards)
<b>ECC</b>	Electronic Communications Committee
<b>FDMA</b>	Frequency Division Multiple Access
<b>FEC</b>	Forward Error correction
<b>FSK</b>	Frequency Shift Keying
<b>GNSS</b>	Global Navigation Satellite Service
<b>HAS</b>	High-Accuracy Service (Galileo E6)
<b>IARU-R1</b>	International Amateur Radio Union ( <a href="#">Region 1</a> ) <sup>1</sup> ;
<b>ICD</b>	European Union, "Galileo Open Services Signal in Space Interface Control Document (OS SIS ICD)"; <a href="http://ec.europa.eu/growth/sectors/space/galileo/">http://ec.europa.eu/growth/sectors/space/galileo/</a>
<b>ISU</b>	Interference Suppression Unit
<b>ITU-R</b>	ITU Radiocommunications Sector
<b>MCL</b>	Minimum coupling loss
<b>MGM</b>	Machine Generated Mode
<b>OS</b>	Open Service (Galileo)

<sup>1</sup> Regions 2 and 3 comprise the same areas as Regions defined by the ITU; IARU coordinates the band plan for the frequency band <https://www.iaru-r1.org/wp-content/uploads/2021/03/UHF-Bandplan.pdf>

<b>PSA</b>	Precision Step Attenuator
<b>PSD</b>	Power Spectral Density
<b>RFI</b>	Radio Frequency interference
<b>RINEX</b>	Receiver Independent Exchange Format
<b>RNSS</b>	Radionavigation-Satellite Service (ITU RR)
<b>RR</b>	ITU-R Radio Regulations
<b>SIS</b>	Signal-In-Space
<b>sps</b>	Symbols per second

## 1 INTRODUCTION

The frequency range 1240-1300 MHz is allocated to the RNSS and is used by the European Galileo system across the frequency range 1258.29-1299.21 MHz in RNSS sub-band E6 for the provisioning of radio navigation satellite services (RNSS). The frequency band 1240-1300 MHz is also allocated to the amateur service and partly to the amateur satellite service (1260-1270 MHz), both on a secondary basis in the ITU Radio Regulations. This band is further shared with primary allocations to the radiolocation (RLS), radionavigation (RNS) on a co-primary basis and with the Earth exploration-satellite service (EESS) (active) on a co-secondary basis. Between 2019 and 2023, similar work within ITU-R studied the global set of RNSS systems in the range 1240-1300 MHz, including additionally the Russian Federation system GLONASS, the Chinese Beidou system and the Japanese Quasi-Zenith Satellite System (QZSS). As a result of that work, Report ITU-R M.2513 [32] and Report ITU-R M.2532 [33] were published, along with Recommendation ITU-R M.2164 [31].

Some cases of harmful interference caused by emissions from the stations in the Amateur Service into Galileo Radionavigation-Satellite Service (RNSS) (space-to-Earth) receivers operating in the E6 sub-band have been observed by two Administrations. An interference was documented few years ago at a Galileo reference receiver located in Munich (Germany) where one broadband amateur application caused harmful interference to the receiver in the frequency band 1260-1300 MHz. The signal was concluded to be an amateur TV emission (analogue and digital) from a station. A second interference has also been reported and documented in this report, where multiple events from a single source were observed in May/June 2021 in the region of Varese (Italy), and assessed by the Joint Research Centre (JRC) of the European Commission have been presented. It was found out that the interference was caused by a strong narrowband emission received at 1297.3 MHz and characterised by a strong power, being more than 40 dB above the noise floor. The emission was analysed, and it was identified to be an FM modulated signal transmitted by an Amateur Radio Repeater.

With the implementation of the Galileo system in the E6 sub-band, it has become necessary to study the operating conditions for applications and operating modes in the amateur and amateur satellite services to assess their potential for interference into the terrestrial Galileo receivers and develop guidance to ensure the protection of these receivers whilst enabling continued use of this band by the amateur services and ensuring the continued long-term development of both amateur and amateur satellite services in this band.

For radio amateurs worldwide the allocation to the amateur service in the frequency band 1240-1300 MHz, known as the "23cm-band", is an important band for both narrowband and wideband applications as an entry point for microwave frequency propagation monitoring and communication experiments. There is an established base of installed stations that have been in operation for 40 years or more.

This Report proposes theoretical studies to estimate the amplitude and geographic extent of potential interfering signal levels from amateur service transmissions set against the published receiver protection criteria identified for RNSS Galileo E6 receivers. The MCL simulations indicated interference areas around radio amateur stations with an extent of several km, depending on the nature of the amateur emission (from narrowband telegraphy and satellite uplink up to wideband digital television). Information from amateur service operations indicates a low density of actively transmitting amateur stations and further studies consider the relative number of impacted receivers compared to the overall number of deployed RNSS receivers assumed.

Additionally, it details two measurement campaigns using representative amateur emissions to understand the impact of the various modes of amateur service operation on the RNSS receivers.

The conclusions from the studies can be used to develop scenarios with conditions or limitations for administrations to help ensure the appropriate protection of RNSS receivers from transmissions from the amateur services.

## 2 AMATEUR SERVICES

### 2.1 AMATEUR SERVICES IN 1240-1300 MHz

#### 2.1.1 Introduction

The ITU Radio Regulations allocate the frequency band 1240-1300 MHz to the amateur service on a secondary basis. In addition, footnote No. 5.282 identifies the band 1 260-1270 MHz for the amateur satellite service subject to not causing harmful interference to other services operating in accordance with the table of allocations. No. 1.56 defines the amateur service as: "A radiocommunication service for the purpose of self-training, intercommunication and technical investigations carried out by amateurs, that is, by duly authorised persons interested in radio technique solely with a personal aim and without pecuniary interest." According to this, the amateur service incorporates a large portfolio of different applications in terms of signals and usage scenarios.

#### 2.1.2 Characteristics of amateur signal emissions

The characteristics of typical applications are shown in Table 1.

**Table 1: Amateur service applications and usage scenarios in the frequency range 1240-1300 MHz**

Application	Typical Bandwidth	Details	Remarks
Digital Voice	12.5 kHz (Tetra: 25 kHz)	DMR, D-Star DV, NXDN, Tetra, APCO 25, C4FM	simplex and repeaters (interconnected by the Internet), mobile/ handheld/ stationary usage DMR: TDMA Access (two timeslots – 50% duty cycle)
Digital Data	12.5-150 kHz	Packet Radio (AFSK 1k2, FSK 9k6), D-Star, Digital Data 128 kbit/s	signal bursts, automatic stations, mobile/ stationary usage
Morse Code	500 Hz	CW (100 WPM)	Moon bounce (high power), Beacons (24/7 automatic stations), Contests (Activity weekends), stationary usage
Analogue Wide	12.5 kHz	FM	simplex and repeaters (some interconnected by the Internet – Echolink), mobile/handheld/stationary usage
Analogue Narrow	2700 Hz	SSB	simplex and linear transponders, Contests (Activity weekends), stationary usage
MGM (machine generated mode)	6-2700 Hz	RTTY, SSTV, PSK31, WSPR	simplex, operator controlled (no automatic stations), Contests (Activity weekends), satellites (only CO-65 in space), stationary usage
Analogue ATV	16-18 MHz	FM-ATV	simplex and repeaters, stationary usage
Digital ATV	2-8 MHz	DATV (DVB-T, DVB-S)	simplex and repeaters, stationary usage

#### 2.1.3 IARU band plan

In accordance with the worldwide amateur service's self-administration, the International Amateur Radio Union (IARU) coordinates the interests of its Member Organisations. The three IARU Regions are organised to broadly mirror the structure of the ITU and its related regional telecommunications organizations. In any case, national regulatory provisions prevail and may lead to different regulations.



Currently IARU recommends the band plan shown in Table 2 for the amateur allocation in the frequency range 1240-1300 MHz in IARU Region 1.

The usage of the frequency range by the amateur and amateur satellite services is driven by the varied operational and experimental interests of the radio amateur users themselves. To support this, the regional band plan is developed to maintain order, avoid conflict and interference between applications, provide understanding of the frequencies for specific activities and form a basis for intra and inter service coordination when required. The regional band plan is not mandatory but is strongly recommended for adoption by the individual national societies. In some cases, it may be adopted to some extent in national regulations, and it may be adjusted on a national basis to facilitate national coordination and sharing with other services in the band. Respecting the band plan is common practice and necessary to facilitate successful radio contacts especially between countries and for inter-regional communications.

The band plan is reviewed periodically and may be adjusted to reflect new technologies and evolving applications. External influences driven by the requirements to share with other services can also be taken into account. The band plan is published by the IARU in the periodically updated IARU R1 VHF Handbook.

**Table 2: IARU Region 1 band plan for 1240-1300 MHz**

Frequency (MHz)	Max. Bandwidth	Mode	Usage
1240-1240.5	2700 Hz	All Mode	(reserved for future)
1240.5-1240.75	500 Hz	Telegraphy MGM	Beacons (reserved for future)
1240.75-1241	20 kHz	FM/Digital voice	(reserved for future)
1241-1243.25	20 kHz	All Mode	1240.000-1241.000 Digital communications 1242.025-1242.250 Repeater output, ch. RS1 -- RS10 1242.250-1242.700 Repeater output, ch. RS11 -- RS28 1242.725-1243.250 Packet radio duplex, ch. RS29 -- RS50
1243.25-1260	Bandwidth limits according to national regulations.	ATV Digital ATV	1258.150-1259.350 Repeater output, ch. R20 -- R68
1260-1270	Bandwidth limits according to national regulations.	Satellite Service	
1270-1272	20 kHz	All Mode	1270.025-1270.700 Repeater input, ch. RS1 -- RS28 1270.725-1271.250 Packet Radio duplex, ch. RS29 -- RS50
1272-1290.994	Bandwidth limits according to national regulations.	ATV Digital ATV	
1290.994-1291.481	20 kHz	FM Digital voice Repeater INPUT	RM0 (1291.000) -- RM19 (1291.475) 25 kHz spacing
1291.494-1296	Bandwidth limits according to national regulations.	All Mode	1293.150-1294.350 Repeater input, R20 (1291.475) - R68 (1294.350)
1296-1296.15	500 Hz	Telegraphy MGM	1296.00-1296.025 Moonbounce 1296.138 PSK31 centre of activity

Frequency (MHz)	Max. Bandwidth	Mode	Usage
1296.15-1296.8	2700 Hz	Telegraphy MGM SSB	1296.200 Narrowband centre of activity 1296.400-1296.600 Linear transponder input 1296.500 Image center (SSTV, FAX etc) 1296.600 Narrowband data center (MGM, RTTY ...) 1296.600-1296.700 Linear transponder output 1296.741-1296.743 experimental MGM (500 Hz) 1296.750-1296.800 Local Beacon (10 W ERP max)
1296.8-1296.994	500 Hz	Telegraphy MGM	BEACONS EXCLUSIVE (b)
1296.994-1297.481	20 kHz	FM Digital voice Repeater OUTPUT	RM0 (1297.000) -- RM19 (1297.475) 25 kHz spacing
1297.494-1297.981	20 kHz	FM Digital voice	1297.500-1297.975 SIMPLEX channels 25 kHz spacing SM20 - SM39 1297.500 FM activity centre 1297.725 Digital Voice Calling 1297.900-1297.975 Simplex FM Internet Voice gateways
1298-1299	20 kHz	All Mode	General mixed analogue or digital use 25 KHz spacing channels 1298.005 RS1 1298.9755 RS1
1299-1299.75	20 kHz	All Mode	Arranged as 5x150 kHz channels for high-speed Digital Data (DD) usage: Centers: 1299.075, 1299.225, 1299.375, 1299.525, 1299.675 MHz (+/- 75 kHz)
1299-1299.75	20 kHz	All Mode	8x25kHz channels (available for FM/DV use): Centers: 1299.775, 1299.975

#### 2.1.4 Amateur Station Categorisation

There are many applications in the amateur service, but the stations and their usage patterns can be broadly categorised into three types:

- i) Home Station.
- ii) Temporary "Portable" Station.
- iii) Permanent installations (away from an individual's home address).

**Table 3: Summarising the Amateur and Amateur Satellite Applications against the Station Types**

Application	Station Type				Comments
	Home	Temporary	Installation		
			Repeater	Beacon	
Voice (Analogue) SSB	Yes	Yes			Long distance tropospheric weak signal ops. (incl. EME)
Voice (Analogue) NBFM	Yes	Yes	Yes		Local neighbourhood communications Satellite comms
Voice (Digital)	Yes		Yes		Local neighbourhood communications
Telegraphy	Yes	Yes		Yes	Long distance tropospheric weak signal ops. (incl. EME)
Analogue Television	Yes	Yes	Yes		Legacy technology, deployments reducing
Digital Television	Yes	Yes	Yes		State of the art technology, deployments increasing
MGM	Yes	Yes		Yes	Long distance tropospheric weak signal ops. (incl. EME)
Data	Yes	Yes (Mobile)	Yes		Local neighbourhood communication links

The operational details are considered specific to the band 1240-1300 MHz as they are dependent upon the nature of the equipment needed and operator skills to operate in this band as well as the propagation characteristics.

It should also be kept in mind that often nationally specific conditions can lead to variations in the operating pattern in particular the frequencies used by permanent installations.

#### 2.1.4.1 Home Station

This would be installed at the usual station licence holder home location. The majority of home station usage is for narrowband terrestrial ad-hoc communications with other similarly equipped amateur stations. However, since the propagation characteristics are more challenging than those in lower UHF and VHF bands the band would not be the first choice for casual contacts or group/club on-air gatherings. Most stations are better equipped in the lower frequency bands for this type of operation. Casual random calls under flat propagation conditions are rare as high antenna gain and narrow beam widths preclude useful "broadcast" calls. The highest level of home station activity occurs during (usually competitive) scheduled activity periods that take place on a publicised regular basis during weekday evenings and a number of weekends throughout the year. Generally analogue narrowband Morse, SSB and MGM applications are used in the range 1296-1298 MHz.

Enhanced propagation conditions tend to be variable and can occur randomly throughout the year. They may last from minutes to days depending on the mechanism at work. These can encourage operation although activity levels will be less compared with the more popular lower UHF and VHF bands. Generally analogue narrowband Morse, SSB and MGM applications are used in the range 1296-1298 MHz.

In order to extend the communication distance that can be achieved, this band is popular amongst a few stations suitably equipped to overcome the losses inherent in an earth-moon-earth (EME) reflected path. Of course, these are only possible when the moon is visible and require high performance low noise stations with larger antenna systems that may not be compatible with all locations. These weak signal contacts most commonly use analogue narrowband Morse and MGM applications in the range 1296-1298 MHz. MGM applications are most commonly used for random contacts.

This band is a popular choice for Amateur TV (ATV) applications due to the bandwidth available. Nowadays digital ATV (DATV) is encouraged and becoming the most popular application. As discussed above, random activity is quite rare but again activity (and contest) periods are scheduled as a focus for operation and experimentation. Simplex TV operation tends to occur around 1255 MHz.

Operation through amateur satellites takes place within the uplink only band at 1260-1270 MHz and these can include tele-command activities as well as direct narrowband voice and low-rate data communications. There are four currently active in this band at present, but this is a lively area of interest.

#### *2.1.4.2 Temporary "Portable" Station*

Often the propagation constraints experienced for a home station (usually due to local clutter) can be overcome in part by temporarily siting a station in an advantageous position (usually high ground) away from the home location and usually in a rural setting. Again, the majority of usage is for terrestrial ad-hoc communications with other amateur stations for short duration narrowband contacts usually associated with scheduled (competitive) activity periods.

ATV activity is also possible, although random activity is rarely seen outside scheduled activity (and contest) periods which act as a focus for operation and experimentation.

EME activity is unlikely as there is no advantage to be gained.

#### *2.1.4.3 Permanent Installation*

Permanent installations include specific voice repeaters, ATV (and occasionally data) repeaters and propagation beacons. As permanent stations, these are licensed in their own right for their specific location, operating frequency and output power (as ERP). The licence is usually associated with a licensed "keeper" of the installation. Propagation beacons usually operate 24/7 and will typically emit a narrowband FSK signal with call sign ID and location information in the range 1296.8-1296.994 MHz.

Voice repeaters usually re-transmit narrowband analogue and digital voice traffic when activated with a signal on the input frequency and are mostly associated with extending mobile user coverage. Propagation at these frequencies does not lend itself to reliable wide area repeater coverage so activity is far less than in lower UHF and VHF bands (and fewer commercial radios are suitable for mobile installations). The most common installations transmit around 1297-1298 MHz although a few experimental systems may operate in other parts of the band.

Data and TV repeater stations transmit wider bandwidth amateur signals and often transmit test signals when not being accessed by a user station on the input channel. This band is the most popular for amateur TV repeaters which tend to operate with input and output frequencies in the range 1242-1260 MHz. Actual assignments can be nationally dependant. There are cases where alternative output frequencies are used to facilitate national inter-service coordination (e.g. UK TV repeater output frequencies are in the range 1300-1325 MHz).

### **2.1.5 Typical Amateur Station Type Characteristics**

There is no standard amateur station. The following antenna types and power levels are typical based on published information about the activity periods and operating contests. In general home and temporary stations would use highly directional antennas.

#### *2.1.5.1 Home Station*

Most Home Stations will use a single directional beam antenna, however in a few cases multiple beam antennas can be combined to increase the array gain. This is more usual for EME operators for whom high antenna gain is essential for overcoming the high path and reflection loss. A higher performance EME station might use a medium size dish antenna.

**Table 4: Home station parameters**

Antenna Type	Gain Typical	3 dB Beam width
Single Yagi beam (23 to 55 element)	18 to 21 dB	18 to 10 degrees
Multiple Yagi (for EME)	21 dB	10 degrees
Dish antenna (for EME)	(4m) 32 dB	4 degrees

Analysis of a typical activity period results (non EME) shows that around 15% of active stations used a multi-antenna array.

Analysis of the same activity period showed the following spread of transmitter power levels (NB: 100% = 34 stations only):

**Table 5: Home station power ranges**

Power Range (Watts)	% Stations
Up to 10	47% (Note 1)
11-25	9%
26-100	26%
101-300	12%
Over 300	6%
Note 1: This corresponded to 16 stations from the activity period surveyed.	

For EME operation experiences have shown that a minimum performance station could expect to make MGM based contacts using around 50 W of power into a multiple antenna beam array. Higher performance stations are likely to require at least around 10 dB more *e.i.r.p.* through a combination of power level and increased antenna gain.

#### 2.1.5.2 Temporary "Portable" Station

As with Home Stations there is a spread of the same antenna types that might be used. Similarly, an analysis of the same activity period as above shows that only 15% of stations use multi-antenna arrays. (The actual number was 3).

Analysis of the same activity period shows the following spread of transmitter power levels (NB: 100% = 13 stations only):

**Table 6: Temporary "Portable" station power range**

Power Range (Watts)	% Stations
Up to 10	61.5% (note 1)
11-25	7.5%
26-100	7.5%
101-300	15%
Over 300	7.5%
Note 1: This corresponded to 8 stations from the activity period surveyed.	

### 2.1.5.3 Permanent Installation

Most permanent installations (beacons and repeaters) are less directional and are generally intended to provide coverage over an area. They are usually licensed to operate at a specific ERP.

**Table 7: Permanent Installation types**

Antenna Type	Gain Typical	3 dB Beamwidth
Various (e.g. Alford slot, Colinear array, horn, flat panel, big wheel...)	Up to around 13 dB	Omni to 60 degrees

**Table 8: Permanent Installation ERP range ERP Range (Watts)**

ERP Range (Watts)	% NB Beacons	% Repeaters (ERP)
Up to 10	69%	16%
11-25	8%	76%
26-100	20%	8%
101-300	1%	0%
Over 300	1%	0%

### 2.1.6 Representative antenna heights

The following antenna heights are representative of typical amateur station installations:

- Typical antenna height for a home station = 12 m above ground level;
- Typical antenna height for a temporary station = 3 m to 15 m above ground level;
- Typical height for a permanent installation station = 25 m above ground level.

Permanent installation stations are often installed at an advantageous location to take advantage of elevated local terrain or tall structures in order to increase the effective antenna height.

### 2.1.7 Typical Usage Patterns

For all home and temporary “portable” station applications, narrowband or wideband, the highest number of actively transmitting amateur stations can be found during the scheduled operating and radio-sport contest periods. Table 9 summarises the total scheduled operating and contest periods scheduled in one region for a typical year. As these activities are usually formalised in the amateur operator calendars, the published national results<sup>2</sup> can be consulted to determine the number of transmitting stations that were active during any one activity or contest period.

<sup>2</sup> The analysed results were published by the national radio amateur societies in several European countries.

**Table 9: Scheduled operating periods and active operating station numbers**

Usage type	Annual scheduled operating periods	Total active stations per scheduled operating period	Active temporary stations per scheduled operating period
Narrowband activity period and radio-sport (in the 1296-1297 MHz portion)	Total, on average 108 hours over a year (1.2% of a year)	From 9 to 140 maximum depending on the country reviewed.	15 to 20 maximum depending on the country reviewed.
EME activity (in the 1296-1297 MHz portion)	5 × 24-hour contest periods (1.4% of a year)	Up to 10 maximum depending on the country reviewed. (Maximum < 70 across the European area)	None
Wideband (typically ATV) activity period and radiosport (in any portion identified for ATV applications)	Total, on average 120 hours over a year (1.4% of a year)	From 1 to 24 maximum depending on the country reviewed. (Maximum < 100 across the European area)	10 maximum depending on the country reviewed.

Figures presented in Table 9 identify the estimated amount of time over a one year period when certain parts of the band (depending on the activity) are at their busiest with the highest number of actively transmitting amateur stations.

Table 9 also shows that the number of active stations involved in the EME and wideband activities is considerably lower than those active for narrowband activities.

Permanent installation stations present a different scenario when considering the operational time. Unmanned amateur radio stations are more or less in continuous operation, while manned stations only transmit intermittently. Propagation beacon and repeater station directories from a representative region can be consulted to develop the summary presented in Table 10.

**Table 10: Permanent Installation station operating periods in a typical year**

Usage type	Annual operation	Active installations
Narrowband propagation beacons	Transmitting continuously usually.	From 4 to 20 depending on the country reviewed. Region 1 = 88 in total.
Narrowband repeaters	Low and only when activated on the input frequency by a user station. May transmit more regularly if a beacon mode is present.	From 9 to 19 depending on the country reviewed.
ATV repeaters (the users are usually home stations)	Low and only when activated on the input frequency by a user station in a random and sporadic manner. May transmit more regularly if a beacon mode is present.	From 10 to 18 depending on the country reviewed. 5 to 10 users within the local coverage area transmitting one at a time.

### 2.1.8 Activity factors and operational considerations of amateur transmitting stations in the 1240-1300 MHz band

Activity factor considers the amount of time that any particular station is transmitting during any operational period of activity. All applications involve two-way communication requiring periods of reception as well as transmission. It is usual practice for any home station or temporary portable station to spend more time receiving than transmitting.

Maximum Activity Factor for home station and temporary “portable” stations = 50% and typically less.

Information from national amateur associations suggests that activity periods for weak signal operating and radio-sport are scheduled outside normal business hours.

Any permanent installation station operating in a beacon mode will exhibit a 100% activity factor.

For Home Station applications the amateur radio transmitter is not active for 100% of time and the antenna direction is not fixed. Therefore, the following additional considerations could help to mitigate the potential for interference:

- Transmission time is not continuous. Usually, they will last just a few tens of seconds followed by an equal (but often longer) receiving period;
- The mean power of the most common analogue amateur transmissions in use for narrowband activity periods for weak signal operating and radio-sport (voice (analogue) SSB) is around 30% of the maximum capability of the equipment (i.e. the average power for a 100-watt capable transmitter in use for voice transmissions is around 30 W due to the time varying nature of the RF envelope. Only speech peaks will be at 100 watts);
- Any interference area around the home station is not uniform due to the antenna directivity. For around 80% of directions away from the amateur station any interfering signal will be considerably less than the main beam direction;
- Surveys suggest that only 12% of Home Stations have the capability to transmit at a maximum power of 100 Watts and even fewer have the capability to transmit at a maximum power of 300 W;
- Wideband transmissions (e.g. DATV) at power levels of 100 W and 300 W would require equipment with extremely high-power output capability beyond the reach of amateur radio operators.

For a home Station during narrowband activity periods and radio-sport over a one-year cycle in one country:

- Total hours of active operation: 108 hours = 1.23% of time/year/country/station p.a.;
- 50% active transmitting time = 0.62% of time/year/country/station p.a.

For a home Station during broadband activity periods and radio-sport over a one-year cycle in one country:

- Total hours of active operation: 120 hours = 1.37% of time/year/country/station p.a.;
- 50% active transmitting time = 0.68% of time/year/country/station p.a.

### 2.1.9 User density of amateur transmitting stations in the 1240-1300 MHz band

More details about the density of amateur stations in different countries can also be found in Annex 1, Annex 2, Annex 3 and Annex 4.

As identified above the scheduled national narrowband activity and contest (radio-sport) sessions attract the highest numbers of transmitting stations active on the band. Published national result tables can be analysed to obtain active amateur station locations. Having surveyed result data from five CEPT countries the following figures for station densities are derived based on the overall country land areas:

#### 1 Home station and temporary “portable” station:

- For narrowband activity periods the maximum density of transmitting stations = 0.0002 stations/km<sup>2</sup>;
- For wideband activity periods the maximum density of transmitting stations = 0.0001 stations/km<sup>2</sup>;
- For EME operations the maximum density of transmitting stations = 0.000 013 stations/km<sup>2</sup>.



Recognising that not all active stations may submit a record of their activities, a 33% uplift has been added to the total active stations per scheduled operating period.

**2** Permanent installation:

- For narrowband data and voice repeaters the average density of transmitting stations = 0.000 3 stations/km<sup>2</sup>;
- For wideband ATV repeaters, the average density of transmitting stations = 0.000 1 stations/km<sup>2</sup>;
- For propagation radio beacon stations, the average density of transmitting stations = 0.000 1 stations/km<sup>2</sup>.

In addition, it is noted that there is a tendency for more stations to be active in areas of higher population density. Therefore, a range of density values could be considered appropriate to more accurately reflect the pattern of activity across a country. Based on a more detailed analysis the following active station density can be observed:

**3** Home station and temporary “portable” station:

- For narrowband activity periods the maximum density of transmitting stations can range from 0.00006 to 0.0016 stations per km<sup>2</sup>.

### **2.1.10 Impact of amateur station emissions**

A study to assess the impact of certain amateur station emissions on a deployment simulation of a large number of one type of co-frequency RNSS (space-to-Earth) receivers can be found in section 6.3. A Monte-Carlo methodology is used in this study along with assumptions based on the data in the sections above.

Different methodologies or different assumptions may result in different calculation results.

### 3 RNSS SYSTEMS

RNSS systems are widely deployed around the globe for a wide range of applications. There are currently several systems that transmit signals within the frequency range 1240-1300 MHz. The band 1240-1260 MHz (sub-band G2) is currently used by the Russian Federation GLONASS system [24]-[25] while the band 1258-1300 MHz (sub-band E6) is used by the European Galileo system. Detailed technical information is provided for Galileo within section 3.2.

Systems and networks in the radionavigation-satellite service (RNSS) provide worldwide accurate information for many positioning, navigation and timing applications, including sensitive aspects for some frequency bands and under certain circumstances and applications. The two key RNSS systems developed in the CEPT region and providing global coverage are GLONASS and Galileo. The amateur services facilitate experimental radio communication activities that include transmission and reception of a range of signals providing narrowband voice, data and wideband TV applications.

#### 3.1 TYPICAL RNSS APPLICATIONS IN THE 1240-1300 MHZ BAND

RNSS provides several types of location and positioning services including new services such as high accuracy service<sup>3</sup> and authentication service<sup>4</sup>.

These new services<sup>5</sup> will provide high level of performances in automotive navigation, transportation, environmental management, agriculture, construction, civil engineering, surveying and mapping.

High accuracy and authentication applications are being supported in the E6 sub-band by the E6-B and E6-C signals as described in section 3.2.2 and need to be protected from any interference.

#### 3.2 GALILEO EMISSIONS AND PROTECTION REQUIREMENTS

##### 3.2.1 Galileo system description

The Galileo system consists of a constellation of 30 satellite positions (24 transmitting satellites and six in-orbit active spares) with ten satellites positioned on each of three 56° inclined in equally spaced orbital planes. Each satellite transmits navigation signals on three carrier frequencies. These signals are modulated with a structured bit stream, containing coded ephemeris data and navigation messages, and have sufficient bandwidth to produce the necessary navigation precision without recourse to two-way transmission or Doppler integration. The system provides accurate timing and position determination in three dimensions anywhere on or near the surface of the Earth. One of the three carrier frequencies is within the frequency band, 1258-1300 MHz, with a central frequency at 1278.75 MHz, and the signal baseline transmitted at that frequency is described in the following section.

##### 3.2.2 Galileo E6 Signal Baseline

The Galileo E6 signal baseline is transmitted at the carrier frequency 1278.75 MHz. The E6 signal baseline includes two different signals, the E6-A signal carrying the “Public Regulated Service (PRS)”, and the signal commonly known as “Commercial Service (CS)”, with the components E6-B and E6-C. The E6-B and E6-C signal, which is specified in [1] and [21], includes the newly defined High Accuracy Service (HAS) and Commercial Authentication Service (CAS), as described below. In the following table some basic parameters for the E6-BC signal baseline are provided.

---

<sup>3</sup> [https://www.gsc-europa.eu/sites/default/files/sites/all/files/Galileo\\_HAS\\_Info\\_Note.pdf](https://www.gsc-europa.eu/sites/default/files/sites/all/files/Galileo_HAS_Info_Note.pdf)

<sup>4</sup> [https://www.gsc-europa.eu/sites/default/files/sites/all/files/Galileo\\_HAS\\_SIS\\_ICD\\_v1.0.pdf](https://www.gsc-europa.eu/sites/default/files/sites/all/files/Galileo_HAS_SIS_ICD_v1.0.pdf)

<sup>5</sup> <https://www.euspa.europa.eu/eu-space-programme/galileo/>

**Table 11: Basic parameters for the E6-BC signal baseline**

Service	E6 HAS	E6 CAS
Carrier Frequency	1278.75 MHz	
Signal frequency range	1258-1300 MHz (1258.29-1299.21 MHz)	
Multiple Access Technique	CDMA	
Spreading Modulation	BPSK (5 Mchip/s)	
Code Frequency	5.115 MHz	
Primary PRN Code Length	5115	
Data Rate	1000 sps	-
Minimum Received Power (Note 1)	-155.25 dBW	
Polarisation	RHCP	

Note 1: The minimum received power on the surface of the Earth is measured at the output of an isotropic 0 dBi receiver antenna for any elevation angle equal or above 5°

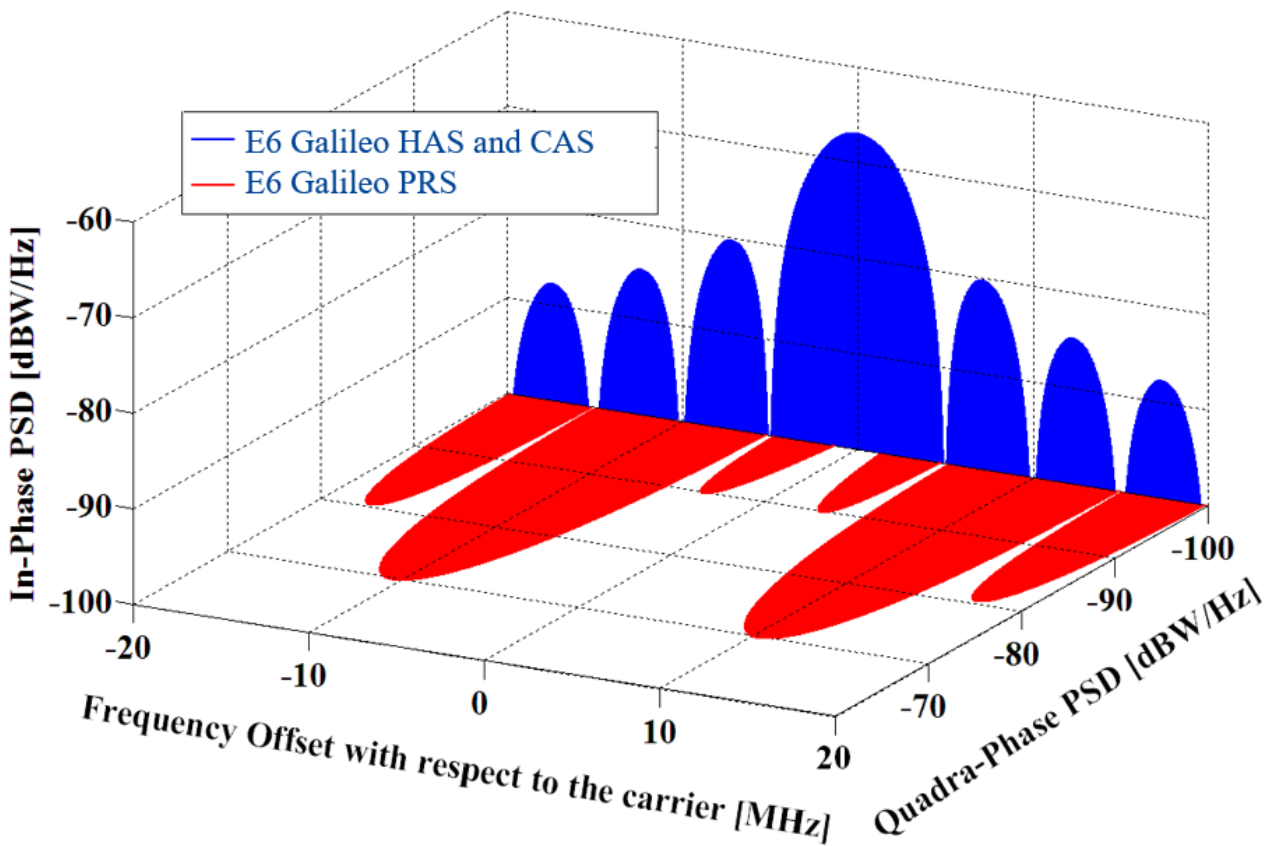

**Figure 1: Power Spectral Density (PSD) of the Galileo E6 signal baseline**

The signal component E6-B carrier the C-NAV data message supporting the High-accuracy service (HAS) and the Commercial Authentication Service (CAS), while E6-C is a data-less pilot component, implementing CAS. The multiplexing of the two signal components is represented in Figure 2.

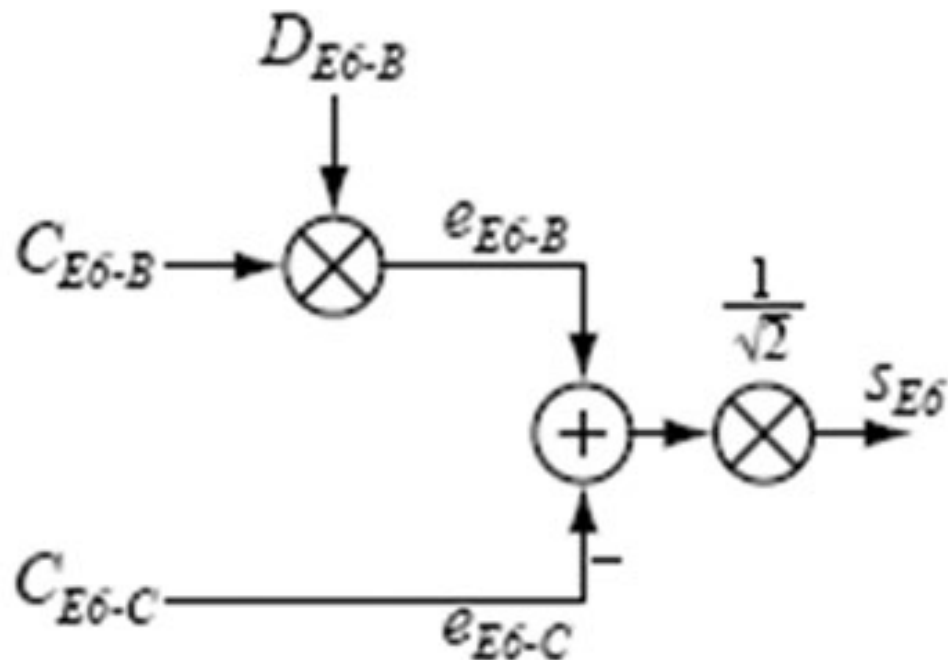

**Figure 2: Multiplexing of the Galileo E-6B+C signal**

### 3.2.2.1 High Accuracy Service (HAS)

The Galileo High Accuracy Service (HAS) is transmitted on the E6-B signal component in the frequency band 1258-1300 MHz, as described above. HAS is aimed at market applications requiring higher accuracy performance than that offered by the Open Service [1], and provides added value services targeting 20 cm accuracy or better, with content and format of data publicly and openly available on a global scale.

The High Accuracy Service complements the current offer of high accuracy solutions for demanding transport-related applications such as automated driving and drones. It also represents a strong entry level solution in precision agriculture and a useful service for mapping and GIS related applications.

### 3.2.2.2 Commercial Authentication Service (CAS)

The Galileo Commercial Authentication Service (CAS) is transmitted on the E6-C component in the frequency band 1258-1300 MHz, as described above. CAS provides the highest level of robustness for RNSS users by fully encrypting the E6-C component to protect against most spoofing attacks by helping to detect the occurrence of spoofing and allowing equipment and users to take mitigating action. The provision of E6-C can also support the adoption of triple-frequency receivers which are more resilient to interference.

Galileo CAS is therefore contributing to ensuring the safety and the security of several applications, such as transport and automotive, which are progressively evolving towards higher digitalization, automation and connectivity. Similarly, the synchronization of critical infrastructures, as well as the mobile-based transaction leveraging on RNSS for user authentication, will benefit from using such a secure signal.

### 3.2.3 Galileo Protection requirements<sup>6</sup>

The Galileo receiver which has to be protected is a ground-based receiver that will track the E6-B and E6-C signals. The function of this receiver is to track either or both the wide-band E6-B (data) and E6-C (pilot) signal components. In the case E6-B is concerned, the receiver will also demodulate data transmitted on this signal component which provides, among other information, Precise Point Positioning (PPP) corrections. In the case the E6-C is processed, the receiver will implement advanced authentication, including the decryption of the spreading code.

The characteristics of this type of receiver that processes the E6-BC signal are provided in Table 12.

**Table 12: Characteristics of a Galileo receiver**

Parameter	Value
Signal frequency range (MHz)	1 278.75 ± 21
Maximum receiver antenna gain in upper hemisphere (dBi)	3 (circular)
Maximum receiver antenna gain in lower hemisphere (dBi)	-6 (circular) (Note 1)
RF filter 3 dB bandwidth (MHz)	40.92
Pre-correlation filter 3 dB bandwidth (MHz)	40.92
Receiver system noise temperature (K)	722
Note 1: The maximum lower hemisphere gain value applies for 5° elevation	

Within Table 13, the technical characteristics and protection criteria (maximum aggregate interference thresholds) for the above receiver are provided, both for narrowband and wideband interference (narrowband continuous interference is considered to have a bandwidth less than 1 kHz, wideband continuous interference is considered to have a bandwidth greater than 1 MHz).

**Table 13: Technical characteristics and protection criteria of a Galileo receiver**

Tracking mode threshold power level of aggregate narrowband interference at the passive antenna output (dBW)	-134.5
Acquisition mode threshold power level of aggregate narrowband interference at the passive antenna output (dBW)	N/A (Note 1)
Tracking mode threshold power density level of aggregate wideband interference at the passive antenna output (dB(W/MHz))	-140
Acquisition mode threshold power density level of aggregate wideband interference at the passive antenna output (dB(W/MHz))	N/A (Note 2)
Note 1: Signal acquisition is performed using the E1-BC signal. The E1-BC signal is in the 1559-1610 MHz RNSS frequency band. Further details for these signals are provided in Annex 3 (Galileo) of Recommendation ITU-R M.1787 [5]. Appropriate acquisition threshold are provided in Recommendation ITU-R M.1903, annex 2, table 2-2, "High-precision" column.	
Note 2: The maximum lower hemisphere gain value applies for 5° elevation	

<sup>6</sup> The Galileo protection requirements are those provided in Recommendation ITU-R M.1902-2 [37]

## 4 SCENARIOS FOR SHARING EVALUATION

### 4.1 FREQUENCY OVERLAP BETWEEN, RNSS AND AMATEURS

Figure 3 shows the spread Galileo E6-signal and the corresponding portions with applications of the amateur service. Except the very wide-band modes of FM-ATV and various options for D-ATV (DVB-T/DVB-S) the remainder of applications falls into three categories which may show different grades of impact, if at all, on the reception and decoding of the Galileo signals.

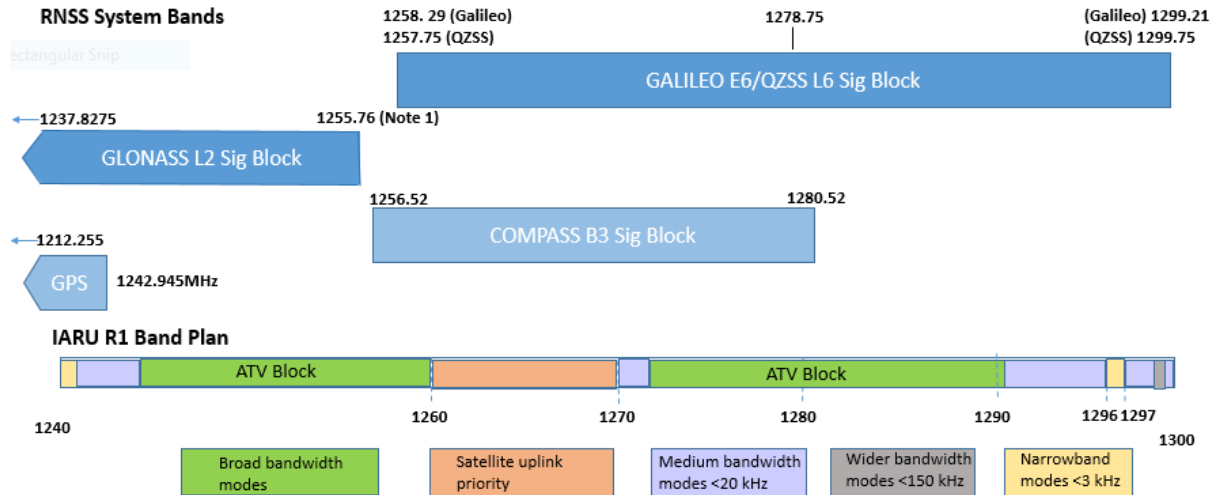

Figure 3: Frequency overlap between, RNSS systems and amateur services applications

### 4.2 PROPAGATION MODEL

The goal is to estimate the dimension of interference areas. For doing so, several propagation models can be used; such as Recommendation ITU-R P.452 [39], Recommendation ITU-R P.1546 [35] or other models used for mobile radio planning, such as Okumura-Hata. The CEPT Monte-Carlo analysis SEAMCAT tool (see ECC Report 252, annex 17 [36]) includes these models and additionally the Extended Okumura-Hata model.

For each of the models cited above, the following considerations can be made:

- Okumura-Hata is relatively easy to use and it is well known for its general reliability, but it has the limitation that ideally the transmitting station should be at least 30 m above the ground. The model is intended to calculate the median loss over a pixel of terrain at distance  $d$  from the transmitter. Because of this, if the model is used to calculate interference area, a margin factor should be inserted in the analysis in order to take into account the spatial variability of the electromagnetic field. If one applies Okumura-Hata, he must be aware of the limitations on its parameters, including a maximum distance of 10 km, a minimum BS antenna height of 30 m. On the other side, since Okumura-Hata is conceived for frequencies up to 1500 MHz, its frequency range suites the case at hand. Within the ECO SEAMCAT tool this is implemented as "Extended Okumura-Hata" and can typically be used for mobile services and other services working in non-LOS/cluttered environments up to 3 GHz, for link lengths preferably below 40 km;
- Recommendation ITU-R P. 1546 [35] does not have the limitation on antenna height of the TX (it can be as low as 10 m), but it has a limitation on the minimum distance, that should be at least 1 km. This model has the advantage of having built in location and time probabilities, so that it can be directly used for the analysis of interference areas;
- On the other side, Recommendation ITU-R P. 1812 [34] is more versatile because it does not have significant limitations on the TX antenna height and the minimum distance, and it considers antenna probability. The minimum distance at which it can be used is 250 m.

For the models in Recommendation ITU-R P. 1546 [35] and in Recommendation ITU-R P. 1812 [34] a tested MATLAB implementation is available to ITU members.

The ECO hosts a Wiki page<sup>7</sup> that provides useful information on the models implemented in the SEAMCAT tool.

A useful comparison of the Recommendation ITU-R P. 1546 [35] model and the Extended Hata model<sup>8</sup>.

For reference, Figure 4 gives the curves of propagation loss, along a path of 100 km, over rural terrain at 1300 MHz, for a transmitting antenna height of 10 meters, a receiving antenna height of 1.5 meters, and a rural terrain. The two curves refer to two location probabilities, namely of 50% and 1%.

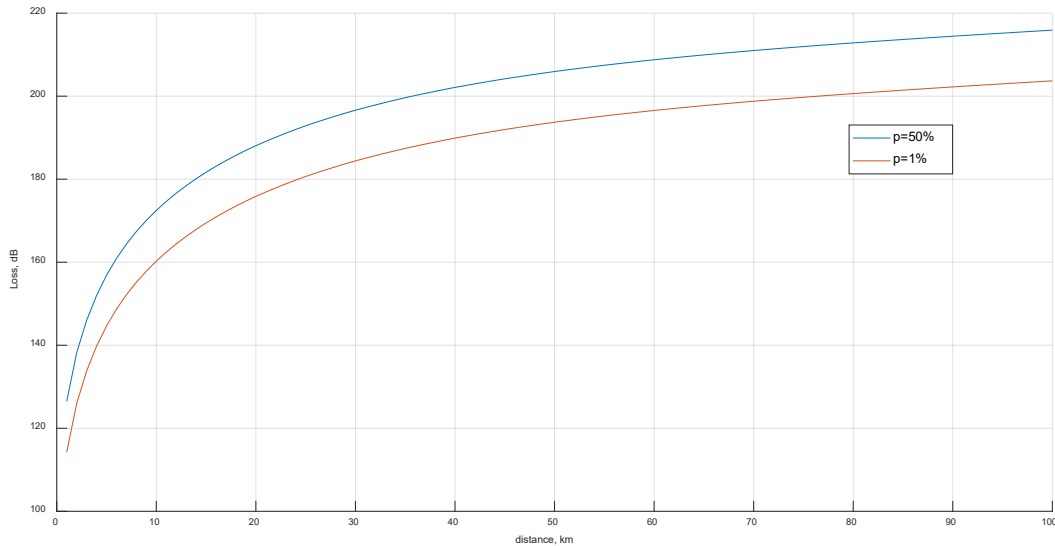

**Figure 4: Curves of propagation loss along a path of 100 km over rural terrain at 1300 MHz for a transmitting antenna height of 10 meters, a receiving antenna height of 1.5 meters and a rural terrain**

If one is interested in the magnitude of interference at very short distances, in the order of magnitude of a few hundreds of meters, more detailed analyses should be conducted, where the case of light of sight and free space propagation is also considered.

#### 4.2.1 Time variability effects

Due to the variation in the atmospheric conditions and propagation conditions, such as ducting, the interfering signal can show time variability. These phenomena are taken into account by the models Recommendation ITU-R. P. 1546 [35] and in Recommendation ITU-R. P. 1812 [34], however, these time effects are mostly relevant over long distances, while at short distances they tend to be negligible.

#### 4.2.2 Space variability effects

The other aspect to be considered is the space variability of the electromagnetic field. By the way it is conceived, a propagation model such as Okumura-Hata gives the estimated median value of the received power in a given pixel of terrain. Inside this pixel of terrain, you can still have slow fading and fast fading. The effect of local statistical variations of the EM field also needs to be taken into account.

In order to appreciate this fact, consider a pixel of terrain 50x50 meters wide. Assume that the maximum tolerable interfering power for the RNSS receiver is  $P_{int}^{MAX}$ . In order to declare that the pixel is free from interference it is not sufficient to verify that the interfering received power from the radio amateur station,

<sup>7</sup> <https://wiki.cept.org/display/SH/A17+Propagation+models>

<sup>8</sup> <https://wiki.cept.org/display/SH/A17.1.3+Using+the+Extended+Hata+vs.+P.1546+models>

calculated with the chosen propagation model, is equal or below  $P_{int}^{MAX}$ . For instance, when its value is exactly equal to  $P_{int}^{MAX}$  this means that 50% of the locations inside the pixel will still be above this value. For this reason, the analysis of interference shall be conducted in such a way that, for a given pixel to be declared interference free, the interfering EM field shall be below the reference threshold for, say, X=99% of its locations.

It is therefore necessary to have a statistical model of the spatial variability of the EM field for a given pixel. In general, such a variation is composed of a slow variation (shadow fading) and fast variation (fast fading), that its due to multipath effects<sup>9</sup>.

A characterization of the spatial variability of the field strength in various frequency band and for different propagation scenarios (the clutter at the location of the RX plays a fundamental role), is implicitly contained in the curves of Recommendation ITU-R P. 1546 [35] and it is also treated in Recommendation ITU-R. P. 1812 [34], but it is excluded by Hata. Should one use Hata, an additional margin for fading should be added, in the same way it is added when Hata is used for mobile radio planning.

If one considers, for instance Recommendation ITU-R. P.1812 [34], for an outdoor location, at 1.5 meters, in the frequency band 1300 MHz, the standard deviation of spatial variation of the received power (that is assumed to be lognormal) is 5.5 dB for the 1300 MHz (see Recommendation ITU-R. P.1812, section 4.8 and table 6). A value of 5.5 dB and the assumption of a lognormal fading clearly refer to the slow variation of the field, while the fast variation is not considered.

Table 14 gives a comparison of the propagation models presented above.

**Table 14: Comparison of propagation models**

Model	Scope	Limitations	Clutter loss consideration	Advantages	Drawbacks
Recommendation ITU-R P.1546 [35]	Point to area	Tx height ∈ [10; 3000] m Distance ∈ [1; 1000] m	The clutter heights around the transmitter and the receiver are represented by two parameters	Can be used without specific terrain data. Works with sea paths. Implemented in SEAMCAT.	
Recommendation ITU-R P.1812 [34]	Point to area	Distance > 250 m	1) At each point on the profile between the transmitter and receiver point a clutter height is added to the terrain height. This profile is used in the diffraction calculation (the antenna heights are also adjusted depending on the clutter at each end). 2) A terminal clutter correction is also applied, dependant on the clutter at the transmit and receiving end; this is the same as in Recommendation ITU-R P. 1546 [35]	Representative of terrain, works with sea paths	Requires detailed terrain height data along the path. Not implemented in SEAMCAT

<sup>9</sup> A comprehensive discussion of fast and slow fading can be found, for instance, in Parsons, *The Mobile Radio Propagation Channel*, 2<sup>nd</sup> Edition, Wiley.



Model	Scope	Limitations	Clutter loss consideration	Advantages	Drawbacks
Okumura-Hata	PtP, broadcast	Tx height > 30 m Mobile station height $\in$ [1; 10] m Distance $\in$ [1; 10] km	Fit on measured data from urban environment, not terrain specific	Easy to use	Not path specific
Extended Okumura-Hata in SEAMCAT	Mobile services and other services working in non-LOS/cluttered environment . Urban, sub-urban and open area environments considered.		Statistical variation of path loss included	Easy to use and implemented in SEAMCAT. Low-height mobile terminals moving in cluttered environment.	Not path specific

## 5 METHODOLOGY

In this section, a description of the analytical methodology used for the sharing and compatibility studies between the RNSS characterised in section 3 and the amateur stations identified in section 2 are detailed. This primary deals with the computation of the amateur antenna radiation pattern listed in Recommendation ITU-R F.1336 [38] as well as the interference exceedance level (IEL) quantity stipulated from the link budget.

### 5.1 CALCULATION OF THE INTERFERENCE EXCEEDANCE LEVEL (IEL)

The IEL metric is the primary focus of the coexistence studies as defined below:

$$P_{RX} = 10\log_{10}(P_{TX}) + G_{RNSS}(\theta) + G_{amateur}(\theta) - L_b - X_{pol} \quad \text{for narrowband signals}$$

$$P_{RX} = 10\log_{10}(P_{TX}) + G_{RNSS}(\theta) + G_{amateur}(\theta) - L_b - X_{pol} - 10\log_{10}(BW) \quad \text{for wideband signals}$$

$$IEL = P_{RX} - RNSS \text{ protection criterion}$$

Where:

- IEL: interference exceedance level (dB);
- $P_{TX}$ : power of the amateur station (W);
- $P_{RX}$ : power at the receiver (dBW);
- $G_{amateur}(\theta)$ : gain of the amateur antenna station calculated using Recommendation ITU-R F.1336 [38] (dBi);
- $G_{RNSS}(\theta)$ : gain of the RNSS antenna given in Recommendation ITU-R M.1902 (dBi);
- $L_b$ : transmission losses calculated using Recommendation ITU-R P.1546 (dB) [35];
- $X_{pol}$ : polarisation loss (dB);
- $BW$ : bandwidth of wideband signal (MHz).

In this setting, a  $P_{RX}$  value should be compared with the protection criteria specified in Recommendation ITU-R M.1902 [37] and the IEL can be determined using the equations above.

### 5.2 COMPUTATION OF THE GAIN OF THE AMATEUR ANTENNA STATION

Following the procedures set forth in Recommendation ITU-R F.1336-5 [38], in the case of average side-lobe patterns referred to in considering c), the gain of the amateur antenna station  $G_{amateur}(\theta)$  from equations above can be calculated as follows:

$$G_{amateur}(\theta) = \begin{cases} G_0 - 12 \left(\frac{\theta}{\theta_3}\right)^2 & \text{for } 0 \leq |\theta| < \theta_3 \\ G_0 - 15 + 10 \log(k + 1) & \text{for } \theta_3 \leq |\theta| < \theta_5 \\ G_0 - 15 + 10 \log \left[ \left(\frac{|\theta|}{\theta_3}\right)^{-1.5} + k \right] & \text{for } \theta_5 \leq |\theta| \leq 90^\circ \end{cases}$$

With:

$$\theta_5 = \theta_3 \sqrt{1.25 - \frac{1}{1.2} \log(k + 1)}$$

Where  $\theta$ ,  $\theta_3$ ,  $G_0$  and  $k$  are defined and expressed in Recommendation ITU-R F. 1336-5, recommends 2.1 [38]. For the studies considered in this report because they are typical antennas that operate in the 400 MHz to 3 GHz range, the parameter  $k$  is defined as 0.7.

All other parameters involved in the calculation of the amateur antenna station  $G_{amateur}(\theta)$  as described in the equation above can be determined from Recommendation ITU-R F.1336-5 [38].

### 5.3 COMPUTATION OF THE TRANSMISSION LOSSES

From Recommendation ITU-R P.1546 [35], the basic transmission loss can be determined from the field strength for 1 kW e.r.p. as follows:

$$L_b = 139.3 - E + 20 \log f$$

Where:

- $L_b$ : basic transmission loss (dB);
- $E$ : field strength (dB( $\mu$ V/m)) for 1 kW e.r.p.;
- $f$ : frequency (MHz).

The basic transmission loss  $L_b$  and field strength  $E$  in equation above can be determined starting from:

- $f$  [MHz]: Desired frequency;
- $t$  [%]: Required percentage of time
- $h_{eff}$  [m]: effective height of the transmitting antenna;
- $h_2$  [m]: receiving antenna height above the ground;
- $R_2$  [m]: representative clutter height above ground;
- Area: Area around receiver
- Dist [km]: Vector of horizontal path lengths over different path zones starting from the transmitter terminal;
- Path: Path zone for each given path length;
- $q$  [%]: Location variability;

The transmission loss ( $L_b$ ) can be determined using the equation above and Recommendation ITU-R P.1546, annex 5 [35].

## 6 SIMULATIONS

In Annex 6, a study that provides the assessment of the geographical extent of the interference caused by transmitting station of the amateur service into Galileo E6 receivers is presented. The annex considers several types of transmitting amateur radio stations and calculates the area around them where the received interference would exceed the protection criterion of the Galileo E6 receivers.

From the simulation studies in Annex 6 some initial aspects were extracted and they are presented below. Firstly, in section 6.1, the maximum distance where the Galileo protection criteria was not respected was determined for different amateur stations and for Region 1. This determination has been performed depending on the amateur application, bandwidth and frequency band.

Secondly, in section 6.2, for specific chosen distances, it was determined in the direction of the maximum amateur antenna gain the exact value of the Galileo IEL.

Both studies have been performed for the following amateur stations:

**Table 15: Amateur antenna characteristics used in sections 6.1 and 6.2**

	Home station 1 (also for Satellite Uplink)	Permanent installation	Home station 2 (only for EME signals)
Antenna	Single Yagi, 18 dBi gain, 18° 3 dB aperture	13 dBi gain, 60° 3 dB beam width	Dish (4m), 32 dBi gain, 4° 3 dB aperture
TX power	1 mW - 300 W	1 mW - 15 W	1 mW - 300 W
Antenna height above ground	12 meters	25 meters	3 meters
Polarisation	Linear	Linear	Linear

Furthermore:

- No cluttering has been considered, which might be considered as a worse-case scenario;
- On the RNSS side, an antenna with a gain of -6 dBi located at 1.5 meters from the ground has been used;
- The polarisation loss used was 3 dB;
- The receiver noise figure used was 3 dB;
- The studies have been done only in a suburban area with a location probability of 50%.

The analysis below is based on the results from Annex 7 where the Galileo protection criteria was chosen to be -134.5 dBW for narrowband amateur applications and -140 dBW/MHz for broadband amateur applications as specified in Recommendation ITU-R M.1902 [37].

### 6.1 SIMULATION RESULTS: MINIMUM COUPLING LOSS STUDIES

Using the amateur antennas presented above various amateur applications were studied depending on the frequency band as it can be seen in the Table below. The following settings were considered as it is also shown in Figure 3:

**Table 16: Amateur applications characteristics in Region 1 depending on frequency band and protection criteria for Galileo system**

Frequency [MHz]	1260-1270	1270-1271	1271-1290	1290-1296	1296-1297	1297-1300
Amateur application mode	Wider bandwidth mode	Medium bandwidth mode	Broad bandwidth mode	Medium bandwidth mode	Narrowband mode (including EME)	Medium and wider bandwidth mode
Amateur antenna	Home Station 1 (Satellite uplink)	Home Station 1 Permanent Station		Home Station 1, Home Station 2 (EME) Permanent Station		Home Station 1 Permanent Station
Bandwidth	128 kHz or less		1.7 MHz	128 kHz or less		
RNSS protection criteria	-134.5 dBW		-140 dBW/MHz	-134.5 dBW		

**6.1.1 Home station 1**

From Table 15, an amateur antenna with a gain of 18 dBi, an aperture of 18° and located 12 meters above ground was used. Also, the values from Table 16 were used for different amateur transmission powers.

The results in Figure 5 were obtained by taking the maximum distance, in the direction of the maximum amateur antenna gain, where the protection criteria of the RNSS are exceeded.

The highest interference distance is obtained in the frequency band 1271-1290 MHz assuming broadband amateur applications. In this study, for a broadband amateur transmission power of 300 W (See note in section 2.1.8 regarding DATV) the maximum interference distance can reach 18 km in this specific frequency band. It is also important to mention that for narrowband amateur applications (example: in the frequency band 1260-1271 MHz) the maximum interference distance was of 15.65 km. By reducing the transmission power to 5 mW, for narrowband amateur applications the maximum interference distance is reduced to 1.55 km and for broad band amateur applications to 1.9 km although no amateur application would be viable at this power level. From the results obtained for the broadband bandwidth assumed it is clear to see that the frequency bands where there is the highest interference distance could be for broadband band amateur applications. With respect to the choice of the frequency band, it was seen that for some amateur applications in different bands the results coincided.

The conclusion of this first study is that the amateur application impact on the interference distance towards Galileo receivers varies depending on the choice of parameters, and on whether there is narrowband or wideband operation in the band.

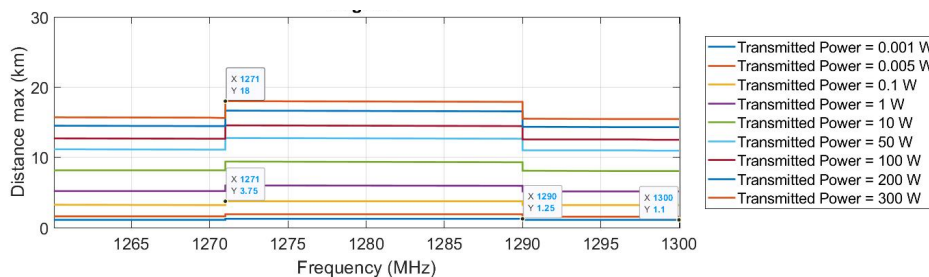

**Figure 5: Home station 1, maximum distance on antenna main beam up to which the Galileo protection criteria is not satisfied, transmission power from 1mW to 300 W**

### 6.1.2 Home station 2

The amateur station called 'Home station 2' is only used for EME transmissions and in only specific frequency bands because the antenna gain for this amateur station is of 32 dBi. In the E6 frequency band EME amateur transmissions only occur in between 1296-1297 MHz so this is why we have only done the study in this frequency band and the results can be observed below in Figure 6.

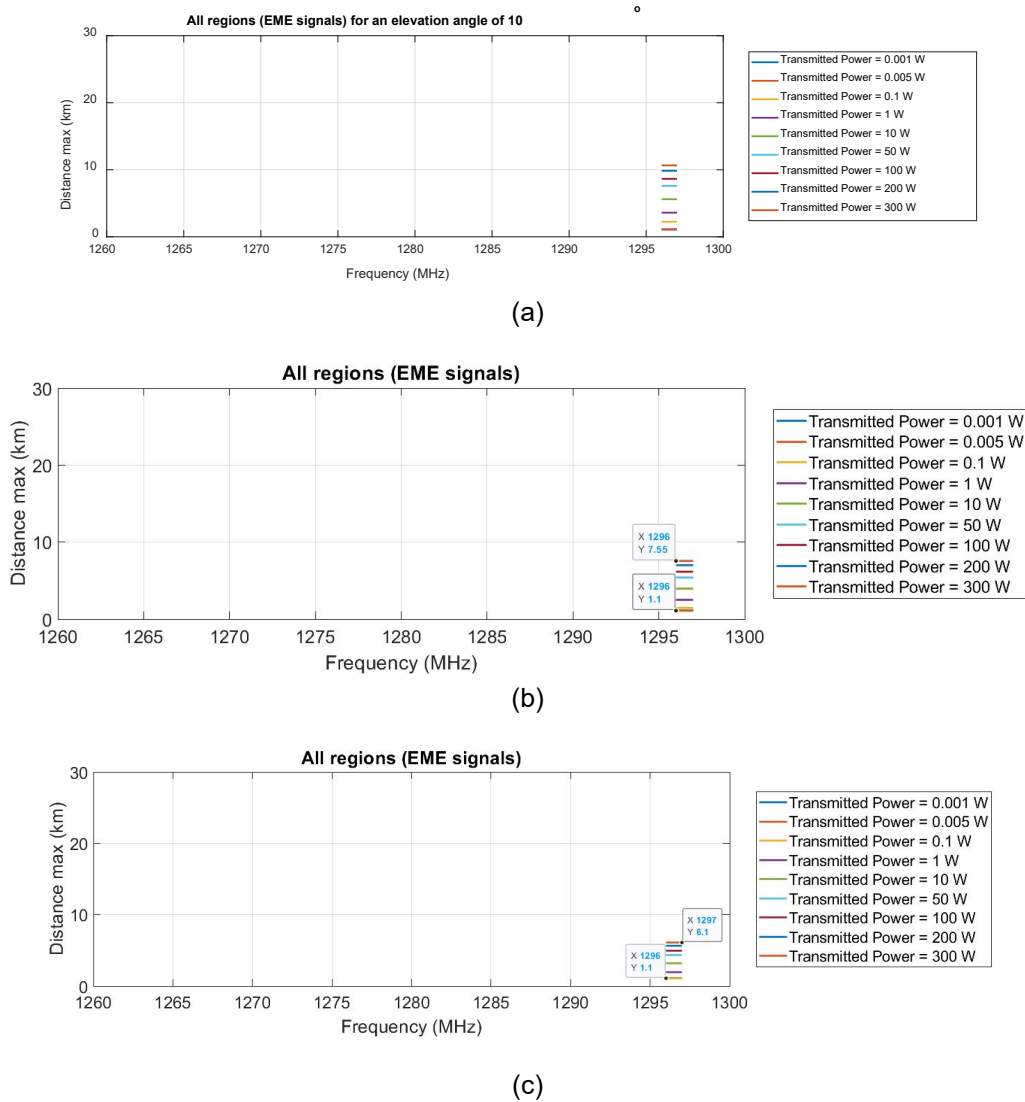
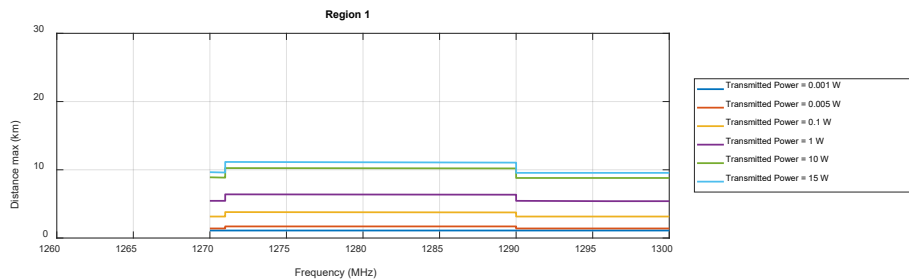

**Figure 6: Home station 2, maximum distance on antenna main beam up to which the Galileo protection criteria is not satisfied, transmission power from 1mW to 300 W for an amateur antenna elevation angle of: (a) 10 degrees, (b) 45 degrees and (c) 90 degrees**

It was considered for the Home station 2 case different transmission powers from 1mW till 300 W. It can be seen that the maximum distance where the Galileo protection criteria is not respected is of 10.65 km for a transmission power of 300 W and an elevation angle of 10 degrees. It is also important to mention that for EME transmissions, the amateur antenna will not be oriented towards the horizon under normal operating conditions, so two other elevation angles were also studied (45 degrees and 90 degrees). As it was expected, when the elevation angle is different from 0 degrees, the maximum interference distance has decreased drastically from 10.65 km till 7.55 km at 45 degrees and 6.1 km at 90 degrees for a power of 300 W. Even with a low transmission power (ex. 5 mW), the protection criteria of Galileo are exceeding till a distance at 10 and 45 degrees of 1.1 km. At 90 degrees, the protection criterion was completely respected at 1 km for low transmission power (5 mW). Note EME communications are not viable with this power level.

### 6.1.3 Permanent station

The same type of study has been done for another type of amateur station that has a slightly different antenna gain lower than 'Home station 1', of 13 dBi, and is also less directive.



**Figure 7: Permanent station, maximum distance on antenna main beam up to which the Galileo protection criteria is not satisfied, transmission power from 1 mW to 15 W**

In conclusion, from the study using a Permanent amateur station it was determined that the highest interference distance of 11 km is obtained in the frequency band 1271-1290 MHz for broad band amateur applications and for 15 W.

Using a transmission power of 5 mW a maximum interference distance of 1.7 km is obtained for broad band amateur applications and a maximum of 1.4 km for narrowband amateur applications. At these distances, without accounting for clutter, with this type of antenna, the protection criteria was not met in the simulations even for a transmission power of 5 mW for the two types of amateur applications.

In conclusion, from this study a table has been extracted that gives the maximum distance where the Galileo protection criteria was exceeded depending on transmission power, region and type of amateur antenna. The studies in this section, which are partially summarised in the two tables below, show that the protection criteria are exceeded for all transmission powers studied.

**Table 17: Maximum distance where the protection criteria of Galileo were not satisfied for broad band amateur applications**

Power	Maximum interference distance		
	Region 1		
	HS1	HS2 at 10 deg	PS
1 mW	1.25 km	-	1.1 km
5 mW	1.9 km	-	1.7 km
0.1 W	3.75 km	-	3.75 km
1W	5.95 km	-	6.35 km
10 W	9.3 km	-	10.2 km
15 W	-	-	11.15 km
50 W	12.65 km	-	-
100 W	14.35 km	-	-
200 W	15.5 km	-	-
300 W	18 km	-	-

**Table 18: Maximum distance where the protection criteria of Galileo were not satisfied for narrowband amateur applications**

Power	Maximum interference distance		
	Region 1		
	HS1	HS2 at 10 deg	PS
1 mW	1.1 km	-	1.1 km
5 mW	1.55 km	1.1 km	1.4 km
0.1 W	3.25 km	2.25 km	3.15 km
1W	5.15 km	3.6 km	5.45 km
10 W	8.15 km	5.6 km	8.9 km
15 W	-	-	9.55 km
50 W	10.95 km	7.6 km	-
100 W	12.7 km	8.65 km	-
200 W	14.3 km	9.85 km	-
300 W	15.7 km	10.65 km	-

## 6.2 GALILEO IEL EXTRACTED FROM THE MINIMUM COUPLING LOSS STUDIES

From the studies presented in Annex 8, it was also extracted the level of protection criteria exceedance for different distances from the amateur station, different amateur antenna stations and different amateur applications depending on the frequency band.

The same amateur antenna stations presented in Table 15 were used here in order to have consistency over the results.

### 6.2.1 Home station 1

For the amateur 'Home station 1' antenna, 3 distances were chosen and the Galileo IEL was determined depending on the type of amateur application.

The minimum distance where the interference exceedance level was able to be calculated was of 1.05 km because of the limits of the proposed propagation model from Recommendation ITU-R P.1546 [35].



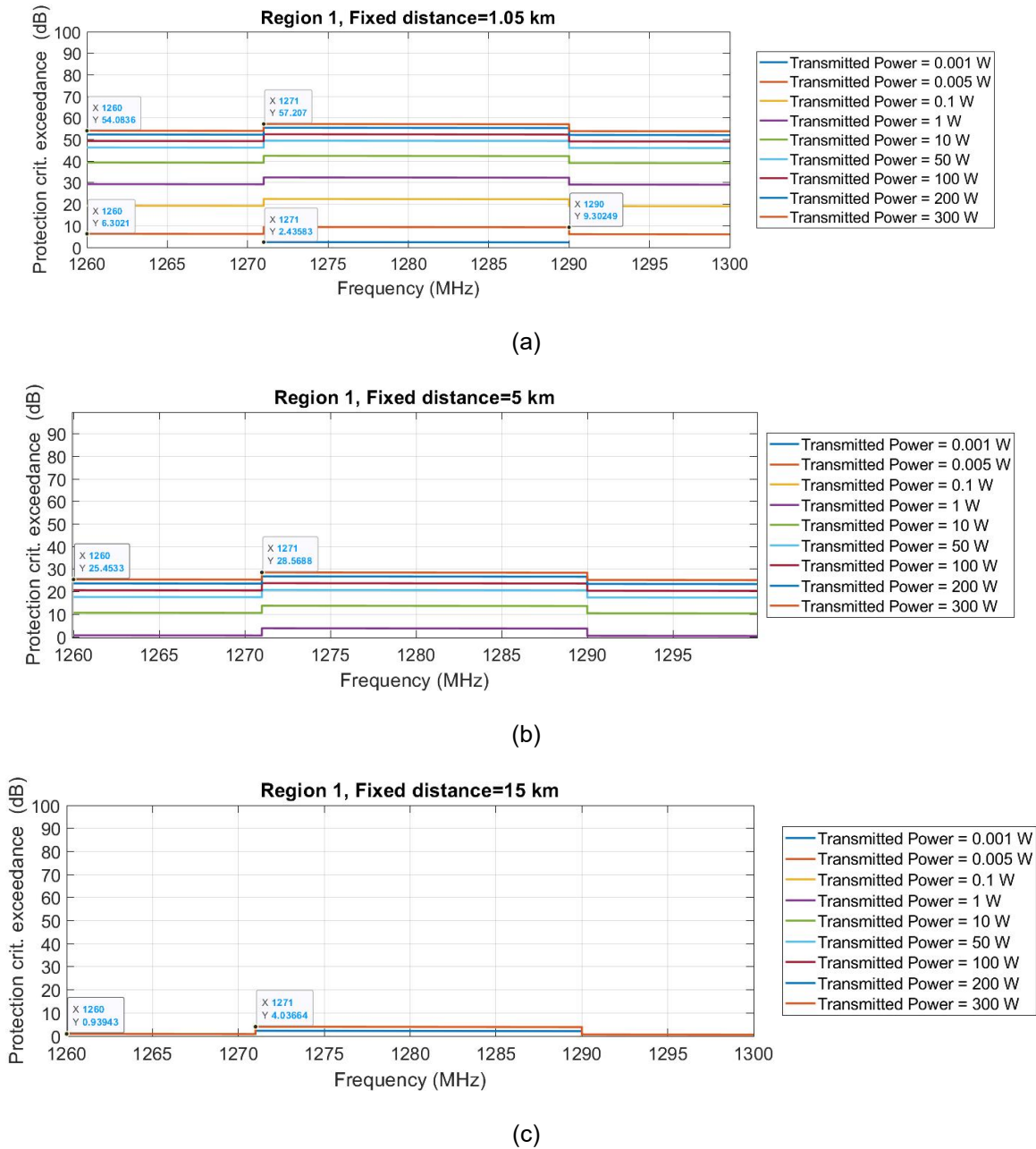

**Figure 8: Galileo IEL extracted from the minimum coupling loss studies for Home station 1 at: (a) 1.05 km, (b) 5 km, (c) 15 km**

In Figure 8, the Galileo IEL for 'Home station 1' was determined depending on 3 chosen distances: 1.05 km, 5 km and 15 km.

In order to consider the worst-case scenario, the determination has been done at boresight (18 dBi) and from the results it is clear to see that the highest interference exceedance has been obtained for the frequency band 1271-1290 GHz for the 3 distances with a maximum 57.2 dB IEL at 1.05 km from the amateur station and using a transmission power of 300 W. For narrowband amateur applications, the maximum IEL was of 54.08 dB using 300 W at 1.05 km from the amateur station. The higher the distance the lower the IEL.

It is also important to mention that for 5 mW transmission power, at 5 km and 15 km, the protection criteria were not exceeded in the frequency band 1260-1300 MHz.

6.2.2 Home station 2

Table 19: Galileo IEL extracted from the minimum coupling loss studies for Home station 2

IEL									
	Region 1 (Home Station 2)								
Distance between Galileo receiver and amateur station (km)	1.05			5			15		
	10	45	90	10	45	90	10	45	90
Elevation angle (degrees)	IEL								
Power	IEL								
1 mW	-	-	-	-	-	-	-	-	-
5 mW	0.3 dB	-	-	-	-	-	-	-	-
0.1 W	13.32 dB	6.5 dB	1.4 dB	-	-	-	-	-	-
1W	23.31 dB	16.5 dB	11.4 dB	-	-	-	-	-	-
10 W	33.32 dB	26.5 dB	21.4 dB	2.5 dB	-	-	-	-	-
50 W	40.3 dB	33.5 dB	28.4 dB	9.5 dB	2.64 dB	-	-	-	-
100 W	43.31 dB	36.5 dB	31.4 dB	12.5 dB	5.66 dB	0.58 dB	-	-	-
200 W	46.32 dB	39.5 dB	34.4 dB	15.5 dB	8.66 dB	3.6 dB	-	-	-
300 W	48.9 dB	41.25 dB	36.2 dB	17.26 dB	10.43 dB	5.35 dB	-	-	-

In Table 19, it was determined the Galileo IEL for 'Home station 2' depending on 3 chosen distances: 1.05 km, 5 km and 15 km.

For an amateur station transmission power of 300 W, for narrowband applications the maximum IEL of 48.9 dB has been obtained at 1.05 km from the amateur station.

For 5 mW transmission power, at 5 km and 15 km, the protection criteria was not exceeded in the entire E6 frequency band. Note EME communications would not be feasible with this power level.

### 6.2.3 Permanent station

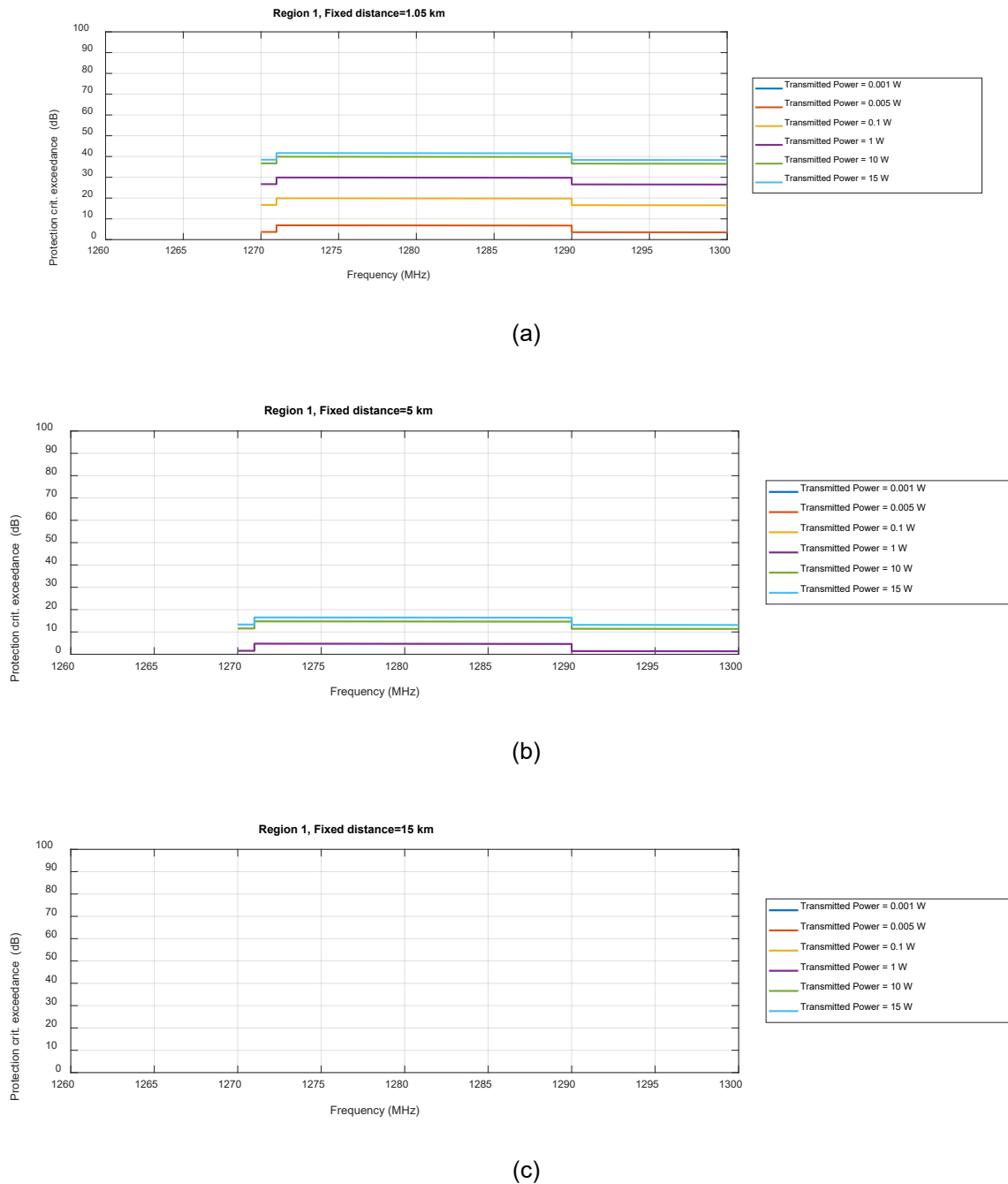

**Figure 9: Galileo IEL extracted from the minimum coupling loss studies for Permanent station: (a) at 1.05 km, (b) at 5 km, (c) at 15 km**

The maximum IEL has also been obtained in this case for broadband amateur applications with a value of 41.5 dB at 15 W transmission power. For narrowband amateur applications, an IEL of 38.3 dB has been obtained.

For 5 mW transmission power, the protection criteria were not exceeded in the frequency band 1260-1300 MHz.

**Table 20: IEL for Galileo for broad band amateur applications at 1.05 km from the amateur station**

Power	IEL		
	Region 1		
	HS1	HS2 at 10 deg	PS
1 mW	2.3 dB	-	-
5 mW	9.3 dB	-	6.9 dB
0.1 W	22.31 dB	-	19.9 dB
1W	32.31 dB	-	29.9 dB
10 W	42.31 dB	-	39.9 dB
15 W	-	-	41.5 dB
50 W	49.3 dB	-	-
100 W	52.31 dB	-	-
200 W	55.32 dB	-	-
300 W	57.2 dB	-	-

**Table 21: IEL for Galileo for narrowband amateur applications at 1.05 km from the amateur station**

Power	IEL		
	Region 1		
	HS1	HS2 at 10 deg	PS
1 mW	-	-	-
5 mW	6.3 dB	0.3 dB	3.7 dB
0.1 W	19.31 dB	13.32 dB	16.7 dB
1W	29.31 dB	23.31 dB	26.7 dB
10 W	39.31 dB	33.32 dB	36.7 dB
15 W	-	-	38.3 dB
50 W	46.3 dB	40.3 dB	-
100 W	49.31 dB	43.31 dB	-
200 W	52.32 dB	46.32 dB	-
300 W	54.08 dB	48.09 dB	-

In conclusion, from this second IEL study two tables have been extracted that give the IEL for Galileo at 1.05 km from the amateur station depending on transmission power, and type of amateur antenna. The study has shown that the maximum IEL obtained was of 32.31 dB for broadband amateur applications and of 29.31 dB for narrowband amateur applications using a transmission power of 1 W. Furthermore, from the studies in this section which are partially summarised in Table 20 and Table 21 show that the protection criteria are exceeded

no matter the transmission power at 1.05 km from the amateur station. However, at 5 km from the amateur station the Galileo protection criteria was respected for all cases using a transmission power of 5 mW. Note that section 9 describes options for RFI mitigation that could be used if the protection criterion is exceeded.

### 6.3 SIMULATION RESULTS: IMPACT OF CERTAIN AMATEUR STATION EMISSIONS ON A DEPLOYMENT SIMULATION OF A LARGE NUMBER OF CO-FREQUENCY RNSS (SPACE-TO-EARTH) RECEIVERS

This study provides one way to quantify the extent of interference occurring between a station of the amateur service and a population of RNSS receivers around that station. Simulations assuming the following scenarios have been carried out:

- a) Fixed narrowband amateur "Home" station and static RNSS receivers in fixed locations where the number of receivers is based on the population density and an estimated RNSS receiver "ownership" factor.
- b) Fixed narrowband amateur "Home" station and mobile RNSS receivers, onboard moving cars.
- c) Fixed broadband amateur "Home" station (ATV) and mobile RNSS receivers, on board moving cars.
- d) Fixed narrowband amateur "Permanent" station (e.g. voice repeater output channel) and mobile RNSS receivers, on board moving cars.
- e) Fixed broadband amateur "Permanent" station (e.g. ATV repeater output channel) and mobile RNSS receivers, on board moving cars.

Each simulation calculates the signal level received at the individual RNSS receivers from an amateur station transmitter. The simulation area depends upon the amateur station density and the number of RNSS receivers placed in the area is based on assumptions about the population and ownership factor.

In case a) above the RNSS receivers remain fixed but are re-positioned for each run of the simulation. In cases b) and c), the mobile RNSS receivers are moved between each set of calculations according to a vehicle speed and trajectory across the simulation area. For each simulation run a new set of vehicles starting positions and speed assignments are made.

The received levels are compared to the protection criteria and if above this level the receiver is labelled "impacted" so that the statistics of the impacted receivers can be collated to determine the mean percentage of impacted receivers from the simulation population.

Similar to other studies in this Report, these simulations consider only amateur transmissions co-frequency with RNSS receivers. Furthermore, these simulations do not consider any impact of frequency offset from the RNSS system centre frequency.

#### 6.3.1 Fixed home Station and fixed RNSS receiver Simulation

In this simulation fixed amateur home stations and fixed RNSS receivers are considered. The number of receivers is based on the population density and an estimated "ownership" factor. RNSS receivers are considered to be in fixed locations and the number of receivers is based on the population density and an estimated RNSS receiver "ownership" factor.

##### 6.3.1.1 *Simulation areas and propagation model parameters*

The amateur station (stn) densities determine the simulation areas from a range from 0.00006 to 0.0016 stations/km<sup>2</sup> with an average of 0.0002 stations/km<sup>2</sup>.

The amateur station density assumed in all simulations:

- Average Home Station and Portable station density = 1 stn / 5000 km<sup>2</sup>;
- Minimum Home Station and Portable station density = 1 stn / 16,700 km<sup>2</sup>;
- Maximum Home Station and Portable station density = 1 stn / 625 km<sup>2</sup>.

The simulation area according to each amateur station density:

- Average Home Station and Portable station density = 70.71 x 70.71 km;

- Minimum Home Station and Portable station density = 129.228 x 129.228 km;
- Maximum Home Station and Portable station density = 25 x 25 km.

The propagation model parameters are:

- Recommendation ITU-R P. 1546 [35] MATLAB code provided by ITU. Latest update (3 May 2019) is available from <https://www.itu.int/md/R15-WP3K-C-0289/en>;
- Location variability: 50%;
- Required percentage time: 1%.

The simulation areas were populated with RNSS receivers in accordance with Table 22 for each propagation model area parameter (Rural, Urban or Dense Urban):

**Table 22: Number of RNSS receivers placed in each simulation area**

	Minimum amateur station density	Average amateur station density	Maximum amateur station density
Rural	96,860	29,000	3,625
Urban	198,730	59,500	7,438
Dense Urban	1,706,740	511,000	63,875

In order to check the appropriateness of these figures, population was consulted<sup>10</sup> and three different population densities can be identified:

- 1 “Rural”, with a density of 58 inhabitants / km<sup>2</sup>;
- 2 “Dense Urban”, with a density of 1022 inhabitants / km<sup>2</sup>;
- 3 “Urban”: average is 119 inhabitants / km<sup>2</sup>.

The RNSS receiver numbers in Table 22 can be attained assuming just 10% active receivers across the population which might be pessimistic. The actual percentage of active receivers in final deployments may be higher and is yet to be determined.

The population of RNSS receivers for the simulation (**N**) = (Simulation area) \* (Population density) \* (Active Receivers).

### 6.3.1.2 Simulation Parameters

The following parameters were assumed for the amateur home station and the RNSS receivers:

- Transmitter frequency: 1297 MHz;
- Transmitter Antenna gain: 18 dBi;
- Transmitter power: 150 Watts;
- Effective height of the amateur station antenna: 12 meters;
- Receiver antenna height: 1.5 meters;
- Receiver max interference threshold: -134.5 dBW for narrowband applications (Ref: Recommendation ITU-R M.1902-2, Table 1, receiver type 3b [37]);
- Receiver antenna gain: -6 dBi (Ref: Recommendation ITU-R M.1902-2, table 1, receiver type 3b), 0 dBi and 3 dBi (Ref: Recommendation ITU-R M.1902-2, table 1, receiver type 3b), omnidirectional;
- Polarisation loss: 3 dB;
- Recommendation ITU-R P. 1546 [35] ‘area’ parameter: rural, urban and dense urban;

<sup>10</sup> Based on the National Institute for Statistics (INSEE) of France. “Rural” is based on data for the region of Bourgogne, “Dense Urban” on data from Île-de-France and “Urban” on the average for urban areas.

- Recommendation ITU-R P. 1546 clutter height: 10 m, 20 m and 30 m (according to rural, urban or dense urban area parameter respectively). Note that a different clutter height of 0 m is also used in other analyses such as those in ANNEX 7;
- Recommendation ITU-R P. 1546 Location variability: 50%;
- Recommendation ITU-R P. 1546 Required percentage time: 1%.

### 6.3.1.3 Simulation Method

At each simulation iteration step (one run), the victim receivers are randomly placed in the simulation area. The (x,y) coordinates of each receiver are initialised from two distinct random uniform distributions.

For each receiver we compute:

- Distance to the transmitter;
- Angle to the main lobe of the transmitter antenna.

From the angle to the main lobe, the antenna gain is estimated according to ITU-R Recommendation F.1336-5 [38]. Then the received level is computed as:

- Received level = (transmitter power)+(transmitter antenna gain)+(receiver antenna gain)-(path loss).

Where the path loss value is provided by the Recommendation ITU-R P.1546 MATLAB code.

Each time the received level is above the RNSS receiver interference threshold the receiver is counted as “**impacted**”.

At the end of one simulation step, we have  $m$  receivers impacted from a potential number of victim receivers  $N$ .

The percentage of impacted receivers from the simulation step is then defined as  $100 * (m / N)$ .

The simulation is performed 1000 times and ends with 1000 distinct values for the percentage of impacted receivers. From these the mean percentage of impacted RNSS receivers can be calculated.

### 6.3.1.4 Simulation Results

Mean percentage of fixed RNSS receivers within the simulation area impacted by one static amateur station operating as defined above:

**Table 23: Mean Percentage of impacted fixed RNSS receivers and Standard Deviation**

Area setting and population density	Minimum amateur station density			Average amateur station density			Maximum amateur station density		
	% Impacted RNSS Rx	Standard Deviation		% Impacted RNSS Rx	Standard Deviation		% Impacted RNSS Rx	Standard Deviation	
Rural	0.06%	58 out of 96,860	0.01%	0.20%	58 out of 29,000	0.03%	1.62%	59 out of 3,625	0.21%
Urban	0.02%	40 out of 198,730	0.004%	0.08%	48 out of 59,500	0.01%	0.65%	48 out of 7,438	0.09%
Dense urban	0.02%	341 out of 1,706,740	0.001%	0.06%	307 out of 511,000	0.001%	0.454 %	290 out of 63,875	0.02%

**Table 24: RNSS receiver antenna gain = -6 dBi**

Area setting and population density	Minimum amateur station density			Average amateur station density			Maximum amateur station density		
	% Impacted RNSS Rx		Standard Deviation	% Impacted RNSS Rx		Standard Deviation	% Impacted RNSS Rx		Standard Deviation
Rural	0.118 %	114 out of 96,860	0.011%	0.396 %	115 out of 29,000	0.039%	3.177%	115 out of 3,625	0.306%
Urban	0.048 %	95 out of 198,730	0.005%	0.161 %	96 out of 59,500	0.017%	1.287%	96 out of 7,438	0.134%
Dense urban	0.033 %	563 out of 1,706,740	0.001%	0.111 %	567 out of 511,000	0.005%	0.889%	568 out of 63,875	0.037%

**Table 25: RNSS receiver antenna gain = 0 dBi**

Area setting and population density	Minimum amateur station density			Average amateur station density			Maximum amateur station density		
	% Impacted RNSS Rx		Standard Deviation	% Impacted RNSS Rx		Standard Deviation	% Impacted RNSS Rx		Standard Deviation
Rural	0.163%	158 out of 96,860	0.013%	0.544%	158 out of 29,000	0.043%	4.385%	158 out of 3,625	0.35%
Urban	0.067%	133 out of 198,730	0.006%	0.224%	133 out of 59,500	0.019%	1.779%	131 out of 7,348	0.154%
Dense urban	0.047%	802 out of 1,706,740	0.002%	0.157%	802 out of 511,000	0.005%	1.249%	798 out of 63,875	0.042%

**6.3.2 Fixed Amateur home Station and Mobile RNSS receivers**

In this section, the impact on moving RNSS receivers located in cars is considered. Both the amateur service narrowband emission and amateur service broadband emission with the appropriate interference threshold value are considered.

*6.3.2.1 Simulation Method*

The first simulation step selects random locations for each car according to the vehicle density and simulation area, assigning them a random speed (from 10 to 50 km/h in urban area) and a random heading direction. Each car then moves along the selected heading for 15 minutes (maximum assumed amateur transmission duration). Every 5 seconds (180 individual time steps in 15 minutes), the received level is computed and compared to the RNSS receiver maximum interference threshold.

Number of simulations: 100, each simulating 180 individual time steps (15 minutes/5 seconds).



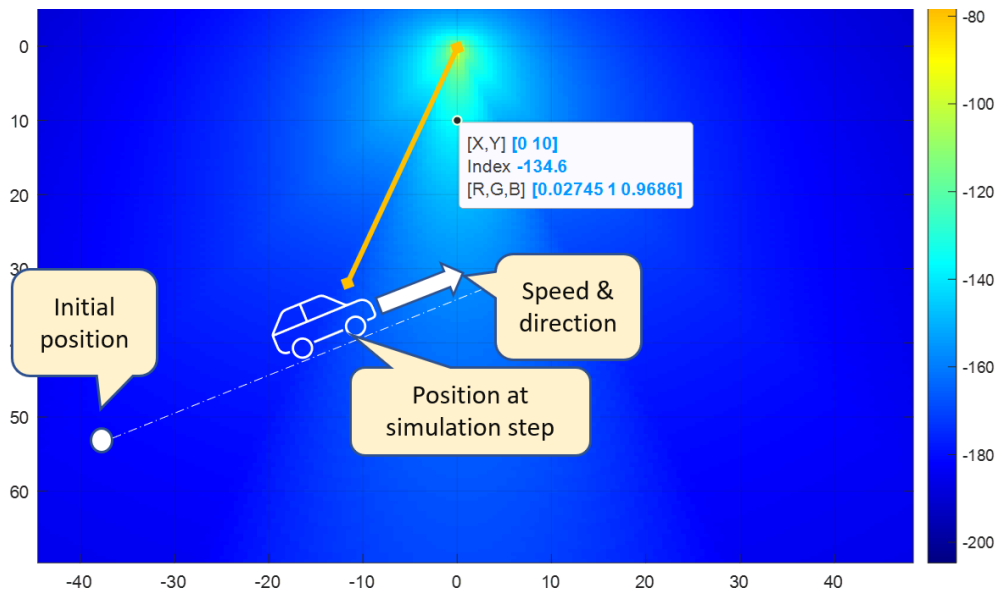

**Figure 10: Mobile RNSS receiver simulation scenario**

At the end of each simulation step we compute:

The percentage of “impacted” RNSS receivers that have faced interference above the protection threshold.

This process is repeated 100 times and the mean percentage and standard deviation are calculated and presented in the results.

### 6.3.2.2 NarrowBand Amateur Home Station

#### Simulation Parameters

The same section 6.3.1.3 simulation parameters were used here with RNSS antenna gain equal to -6 dBi, 0 dBi and 3 dBi. The following vehicular assumptions were made:

- Car density: 330 vehicles/km<sup>2</sup> (according to ECC Report 351 for the urban case);
- Percentage of cars having an active RNSS receiver during the simulation: 50%;
- Speed distribution: uniform, from 5 to 50 km/h;
- Simulated drive path duration for each simulation step: 15 minutes;
- Time step for the drive path: 5 seconds, leading to 180 steps for 15 minutes.

Note: In this simulation, if a RNSS receiver moves outside of the simulation area, it turns around back into the area. Thus, the number of RNSS receivers inside the simulation remains constant.

**Table 26: Number of mobile RNSS receivers placed in each simulation area**

Minimum amateur station density	Average amateur station density	Maximum amateur station density
2755500	825000	103125

The RNSS receiver numbers in Table 26 can be attained assuming 50% active receivers across the population of vehicular receivers which might be pessimistic. The actual percentage of active receivers in final deployments may be higher and is yet to be determined. However, the actual number is relevant only to ensure that enough potential victim receivers are considered in the simulation to achieve stable results.

6.3.2.3 Simulation Results

Mean Percentage of mobile RNSS receivers impacted by one fixed narrowband amateur home station.

**Table 27: Narrowband Amateur Home Station: Mean percentage of Impacted Mobile RNSS receivers and Standard Deviation (RNSS Receiver Antenna Gain = -6 dBi)**

Area Setting Parameter	Minimum amateur station density			Average amateur station density			Maximum amateur station density		
	% Impacted RNSS Rx		Standard Deviation	% Impacted RNSS Rx		Standard Deviation	% Impacted RNSS Rx		Standard Deviation
Rural	0.15%	4133 out of 2755500	0.002%	0.50%	4125 out of 825000	0.008%	3.94%	4063 out of 103,125	0.058%
Urban	0.079%	2176 out of 2755500	0.001%	0.27%	2228 out of 825000	0.006%	2.10%	2166 out of 103,125	0.046%
Dense urban	0.060%	1653 out of 2755500	0.0015%	0.21%	1733 out of 825000	0.0047%	1.67%	1722 out of 103,125	0.038%

**Table 28: Narrowband Amateur Home Station: Mean percentage of Impacted Mobile RNSS receivers and Standard Deviation (RNSS Receiver Antenna Gain = 0 dBi)**

Area Setting Parameter	Minimum amateur station density			Average amateur station density			Maximum amateur station density		
	% Impacted RNSS Rx		Standard Deviation	% Impacted RNSS Rx		Standard Deviation	% Impacted RNSS Rx		Standard Deviation
Rural	0.24%	6613 out of 2755500	0.003%	0.81%	6683 out of 825000	0.01%	6.375%	6574 out of 103,125	0.077%
Urban	0.123%	3389 out of 2755500	0.002%	0.425%	3506 out of 825000	0.007%	3.33%	3434 out of 103,125	0.057%
Dense urban	0.096%	2645 out of 2755500	0.002%	0.332%	2739 out of 825000	0.006%	2.60%	2681 out of 103,125	0.051%

**Table 29: Narrowband Amateur Home Station: Mean percentage of Impacted Mobile RNSS receivers and Standard Deviation (RNSS Receiver Antenna Gain = 3 dBi)**

Area Setting Parameter	Minimum amateur station density			Average amateur station density			Maximum amateur station density		
	% Impacted RNSS Rx		Standard Deviation	% Impacted RNSS Rx		Standard Deviation	% Impacted RNSS Rx		Standard Deviation
Rural	0.302%	8321 out of 2755500	0.003%	1.04%	8580 out of 825000	0.01%	8.163 %	8418 out of 103,125	0.08%
Urban	0.156%	4299 out of 2755500	0.003%	0.537%	4430 out of 825000	0.009%	4.21%	4342 out of 103,125	0.065%

Area Setting Parameter	Minimum amateur station density		Average amateur station density		Maximum amateur station density				
	% Impacted RNSS Rx	Standard Deviation	% Impacted RNSS Rx	Standard Deviation	% Impacted RNSS Rx	Standard Deviation			
Dense urban	0.12%	3307 out of 2755500	0.002%	0.417%	3440 out of 825000	0.008%	3.285 %	3388 out of 103,125	0.055%

For the mobile RNSS receiver case, the percentages are higher for the maximum amateur station density case. However, in the most likely combinations of area setting and station density, the percentage of impacted receivers in the simulation area population is mostly less than 1%.

#### 6.3.2.4 Broadband Amateur Home Station

The same simulation parameters and vehicular assumptions were used as detailed in section 6.3.2.2.1 but in this case using the RNSS receiver broadband interference threshold:

For the amateur service broadband emission:

- Broadband emission bandwidth: 2 MHz (DATV signal);
- Broadband RNSS receiver max interference threshold: -140 dBW/MHz (Ref: Recommendation ITU-R M.1902-2, table 1, receiver type 3b [37]).

The number of RNSS receivers in the simulation = 825,000 assuming a simulation area consistent with the average amateur station density (see Table 23).

#### 6.3.2.5 Simulation Results

Mean percentage of mobile RNSS receivers impacted by one fixed broadband amateur home station:

**Table 30: Broadband Amateur Home Station: Mean Percentage of impacted mobile RNSS receivers and Standard Deviation (RNSS Receiver Antenna Gain = -6dBi)**

Area Setting Parameter	Average amateur station density		
	% Impacted RNSS Rx	Standard Deviation	
Rural	0.612%	5049 out of 825,000	0.008%
Urban	0.325%	2681 out of 825,000	0.006%
Dense urban	0.26%	2145 out of 825,000	0.01%

For an amateur station with an assumed broadband emission, the mean percentage of impacted RNSS receivers for an average amateur station density (based on narrowband station density) remains below 1%.

### 6.3.3 Permanent Amateur Station (Repeater output) and Mobile RNSS receivers

In this simulation, the amateur station parameters are changed to those appropriate for a fixed permanent station (repeater station output channel) and the impact on vehicular RNSS receivers is considered from both a narrowband amateur emission and a broadband amateur emission.

The same simulation method was followed as used in the mobile RNSS receiver scenario in section 6.3.2.1.

### 6.3.3.1 Narrowband amateur Permanent Station

#### Simulation parameters

The following parameters were assumed for the amateur permanent station and the RNSS receivers:

- Average permanent station density = 1 stn / 3333 km<sup>2</sup>;
- Simulation area: According to the station density = 57.7 x 57.7 km;
- Transmitter frequency: 1297 MHz;
- Transmitter antenna gain: 13 dBi;
- Transmitter *e.i.r.p.*: 25 Watts;
- Effective height of the amateur station antenna: 25 meters;
- Receiver antenna height: 1.5 meter;
- Narrowband Receiver max interference threshold: -134.5 dBW (Ref: ITU-R M.1902-2, Table 1, receiver type 3b [37]);
- Receiver antenna gain: -6 dBi, omnidirectional;
- Polarisation discrimination: 3 dB;
- Recommendation ITU-R P. 1546 [35]: 'area' parameter: Rural, Urban and Dense Urban;
- Clutter height values of 10 m, 20 m and 30 m were assumed (available values in variable R2 in the ITU-R MATLAB code, according to rural, urban or dense urban area parameter respectively). Note that a different clutter height of 0 m was used in other analyses such as those in Annex 8. Recommendation ITU-R P. 1546 [35]: Location variability: 50%;
- Recommendation ITU-R P. 1546: Required percentage time: 1%.

Vehicular assumptions:

- Car density: 330 vehicles/km<sup>2</sup>;
- Percentage of cars having an active RNSS receiver during the simulation: 50%;
- Number of mobile RNSS receivers placed in the simulation area = 549 945;
- Speed distribution: uniform, from 5 to 50 km/h;
- Simulated drive path duration for each simulation step: 15 minutes;
- Time step for the drive path: 5 seconds, leading to 180 steps for 15 minutes.

**Note:** Again, if a RNSS receiver moves outside of the simulation area, it turns around back into the area. It means that the number of RNSS receivers inside the simulation remains constant.

The RNSS receiver numbers of 549 945 can be attained assuming 50% active receivers across the population of vehicular receivers which might be pessimistic. The actual percentage of active receivers in final deployments may be higher and is yet to be determined. However, the actual number is relevant only to ensure that enough potential victim receivers are considered in the simulation to achieve stable results.

#### Simulation Results

Mean percentage of mobile RNSS receivers impacted by one fixed permanent narrowband amateur station:

**Table 31: Amateur Permanent Station and Impacted Mobile RNSS receiver results (RNSS Receiver Antenna Gain = -6 dBi)**

Area Setting Parameter	% Impacted RNSS Rx		Standard Deviation
Rural	0.24%	1320 out of 549,945	0.01%
Urban	0.13%	715 out of 549,945	0.005%
Dense urban	0.1%	550 out of 549,945	0.005%

For the permanent narrowband amateur station and mobile RNSS receiver case only a single average density figure is available. All the mean percentage results for impacted RNSS receivers are less than 1%.

### 6.3.3.2 Broadband Amateur Permanent Station

#### Simulation Parameters

The same simulation parameters and vehicular assumptions were used as detailed in section 6.3.3.1.1 but in this case using the RNSS receiver broadband interference threshold:

For the amateur service broadband emission:

- Broadband emission bandwidth: 2 MHz (DATV signal);
- Broadband RNSS receiver max interference threshold: -140 dBW/MHz (Ref: Recommendation ITU-R M.1902-2, Table 1, receiver type 3b [37]).

#### Simulation Results

Mean percentage of mobile RNSS receivers impacted by one fixed broadband amateur permanent station:

**Table 32: Broadband Amateur Permanent Station: Mean Percentage of impacted mobile RNSS receivers and Standard Deviation (RNSS Receiver Antenna Gain = -6 dBi)**

Area Setting Parameter	% Impacted RNSS Rx		Standard Deviation
Rural	0.68%	3740 out of 549,945	0.01%
Urban	0.34%	1870 out of 549,945	0.01%
Dense urban	0.26%	1430 out of 549,945	0.01%

For the permanent broadband amateur station and mobile RNSS receiver case only a single average density figure is available. All the mean percentage results for impacted RNSS receivers are less than 1%.

### 6.3.4 Summary

This study presents results from a simulation methodology to quantify the impact of amateur station emissions on a deployment of a large number of co-frequency Galileo RNSS (space-to-Earth) receivers. In all cases a sufficiently large population of RNSS receivers is considered to ensure stable simulation results. Scenarios are considered with either static or mobile RNSS receivers.

## 7 MEASUREMENTS

This chapter presents a discussion of the results of measurements presented in Annex 5 and Annex 6.

A first measurement campaign was performed in Germany, after some amateur applications caused harmful interference to an RNSS reference receiver located near Munich (Germany) operating in the frequency range 1260-1300 MHz in 2018. Representative amateur emissions were inserted at antenna input port of a 30 MHz bandwidth RNSS receiver, at Galileo E6 centre frequency and with frequency offsets dependent on the type of amateur emission considered in accordance with IARU band plan. Measurements of the post-correlation  $C/N_0$  degradation led to the conclusion that the worst case occurs when an interfering signal is applied on the E6 centre frequency, while frequency separation from centre frequency yields significantly higher tolerable levels for the interfering signal, in particular when this interfering signal falls out of the 30 MHz receiver bandwidth. A non-constant envelope of the interfering signal leads to high scattering of the receivers observed  $C/N_0$ . And a special Interference Suppression Unit (ISU) used for some of the tests can significantly reduce the impact of certain interfering signals, particularly for narrowband signals ( $B < 150$  kHz), but did not lead to strong receiver immunity against the wider amateur television signals.

A second measurement campaign was performed in the region of Varese (Italy) in 2021, after an FM modulated signal transmitted by an Amateur Radio Repeater has caused harmful interference to Galileo E6 receivers multiple times. The effect of amateur emissions with different power levels and different central frequencies was considered on a set of representative RNSS receivers characterised by different front-end bandwidth spanning approximately from 30 MHz to the full 40 MHz. Results show that the two amateur applications which show the highest compatibility potential with RNSS, provided that power levels remain below certain thresholds, are narrowband FM and digital data. On the other hand, amateur television wideband applications caused harmful interference even at relatively low power and therefore offer little compatibility potential, a result which seems almost independent from the considered RNSS receiver bandwidth.

The measurement campaigns have shown that the impact of narrowband or wideband emissions can differ for the same transmitter power level and that relationship between the amateur transmissions and the RNSS receiver centre frequency can also have some impact on the sensitivity to amateur interference. Generally, for narrowband transmissions, if a larger separation between the amateur transmissions and the RNSS system centre frequency can be assured then the impact of the amateur transmissions is reduced. The effectiveness of this may depend on the receiver implementation. Separation is also effective with wideband transmissions but in this case the opportunity for separation may be more limited due to the wider bandwidths. Reducing the bandwidth of wideband modes can improve the situation.

## 8 RESULTS OF STUDIES

The minimum coupling loss studies detailed in section 6 show that there is a potential for amateur station emissions in the range 1258-1300 MHz to be received in Galileo RNSS receivers at levels exceeding the receiver protection criteria defined in Recommendation ITU-R M.1902-2 [37]. The amount of exceedance depends mainly on the power level of the amateur emissions and the separation distance. The power level of the amateur emissions may depend on the specific amateur service application and the type of station deployed. Certain characteristics of the amateur stations (e.g. antenna gain) and operation (e.g. activity factor) may influence the geographic extent of possible interference or the number of RNSS receivers that might receive signals above their protection criteria and for how long. Another study in section 6 uses a Monte Carlo style methodology to evaluate the percentage of Galileo RNSS receivers that might experience received levels exceeding the receiver protection criteria from various amateur station emissions. It is noted that some studies in section 6 did not consider clutter, which is likely an added source of attenuation.

The measurement campaigns reported in section 7 provide more detail on the performance degradation of the Galileo receivers in the presence of amateur signals of various types. These campaigns provide more detail on how the receivers may be more or less susceptible depending on the nature and bandwidth of the amateur signal and where it is placed within the RNSS receiver operating band. In addition, the specific receiver implementation may have some bearing on the susceptibility to interfering signals.

## 9 INTERFERENCE MITIGATION

The results of the studies in this report show that interference into the Galileo RNSS receivers in the range 1258.29-1299.21 MHz could be minimised by the following technical and operational measures:

- Consideration of amateur radio station transmitter power levels;
- Offsetting amateur transmitting frequencies from the most sensitive parts of the Galileo receiver operating band;
- Consideration of amateur service band planning to avoid certain applications in the most sensitive parts of the Galileo receiver operating band;
- Receiver characteristics may differ depending on user needs and performances. Some receivers could therefore benefit from improved characteristics.

In the ITU-R study groups similar work has been carried out in the context of the World Radio Conference instigated by ITU-R Resolution 774 (WRC-19). Amongst other deliverables this resulted in publication of ITU-R Recommendation M.2164-0 [31] which includes a technical annex that takes into account the bullets listed above and proposes resultant guidance.

Recommendation ITU-R M.2164-0 provides guidance on technical and operational measures for administrations authorizing stations operating in the amateur and amateur-satellite services to protect the various RNSS(space-to-Earth) system receivers in differing parts of the frequency band 1240-1300 MHz. The relevant measures for protecting the Galileo receivers in the range 1258.29-1299.21 MHz are contained in the Annex to this Recommendation.

The effect of the technical conditions in the Annex to ITU-R M.2164-0, would be to concentrate medium and higher power narrowband amateur applications in the range 1296 to 1300 MHz, at the top of the band. The usable amateur satellite service frequency range would be restricted to 1 260- 1 262 MHz only from the 10 MHz allocated.

However, no practical amateur radio applications operate at an e.i.r.p. as low as -17 dBW as recommended in the Annex to Recommendation ITU-R M.2164-0, therefore it is not possible to operate any viable narrowband amateur service activity between 1258 and 1296 MHz, no amateur satellite activity between 1 262 and 1270 MHz or any broadband (including ATV) across the entire range 1258 to 1300 MHz.

In conclusion, the annex in Recommendation ITU-R M.2164-0 provides technical and operational measures to be used as guidance by administrations wishing to allow or continue the operation of the amateur and amateur-satellite services across their territory in all or parts of the frequency band 1240-1300 MHz in order to protect RNSS; recognizing that other measures to protect RNSS may be implemented by administrations based on their national circumstances. Following, in the Provisional Final Acts of WRC-23, it was agreed to add a footnote to Article 5 of the Radio Regulations, that mentions Recommendation ITU-R M.2164 and that proposes to ensure that the amateur and amateur-satellite services do not cause harmful interference to radionavigation-satellite service (space-to-Earth) receivers in accordance with No. 5.29. Furthermore, this footnote also mentions that an authorising administration, upon receipt of a report of harmful interference caused by a station of the amateur or amateur-satellite services, shall take all necessary steps to rapidly eliminate such interference.

For the protection of Galileo receivers that operate in the range 1 258-1 300 MHz the relevant necessary technical and operational measures from the annex of Recommendation ITU-R M.2164-0 would be:

- Item 1 points d), e) and f);
- Item 2 points a) and b);
- Item 3 point d);
- Items 4 and 5 may need consideration as required.



## 10 CONCLUSIONS

The frequency range 1240-1300 MHz is allocated on a primary basis to the RNSS and is used by the European Galileo system across the frequency range 1258.29-1299.21 MHz in RNSS sub-band E6 for the provisioning of radio navigation satellite services (RNSS). The frequency band 1240-1300 MHz is also allocated to the amateur service and partly to the amateur satellite service (1260-1270 MHz), both on a secondary basis in the ITU Radio Regulations. This band is further shared with primary allocations to the radiolocation (RLS), radionavigation (RNS) on a co-primary basis and with the Earth exploration-satellite service (EESS (active)) a co-secondary basis. Between 2019 and 2023, similar work within ITU-R studied the global set of RNSS systems in the range 1240-1300 MHz, including additionally the Russian Federation system GLONASS, the Chinese Beidou system and the Japanese QZSS. As a result of that work, Report ITU-R M.2513 [32] and Report ITU-R M.2532 [33] were published, along with Recommendation ITU-R M.2164 [31].

Some cases of harmful interference caused by emissions from the stations in the Amateur Service into Radionavigation-Satellite Service (RNSS) (space-to-Earth) receivers of two Administrations are reported in this document.

The studies detailed in this report show that there is a potential for amateur station emissions in the range 1258-1300 MHz to be received in Galileo RNSS receivers at levels exceeding the receiver protection criteria defined by the Recommendation ITU-R M.1902-2 [37]. The amount of exceedance depends mainly on the power level of the amateur emissions and the separation distance. The power level of the amateur emissions may depend on the specific amateur service application and the type of station deployed. Certain characteristics of the amateur stations (e.g. antenna gain) and operation (e.g. activity factor) may influence the geographic extent of possible interference or the number of RNSS receivers that might receive signals above their protection criteria and for how long. It is noted that some studies in section 6 did not consider clutter, which is likely an added source of attenuation.

The measurement campaigns reported in section 7 provide more detail on the performance degradation of the Galileo receivers in the presence of amateur signals of various types. These campaigns provide more detail on how the receivers may be more or less susceptible depending on the nature and bandwidth of the amateur signal and where it is placed within the RNSS receiver operating band. These testing campaigns show potential interference between certain amateur applications and RNSS within the E6 band. This remains true almost for any of the considered receivers, and it was shown that the results seem almost independent from the specific GNSS receiver bandwidth. In addition, the specific receiver implementation may have some bearing on the susceptibility to interfering signals.

In order to minimise such cases of interference in the future, technical and operational measures to protect RNSS systems have been considered that can allow the amateur and amateur satellite services to continue to operate in part of the band 1258 to 1300 MHz in a way that can reduce the potential for interference into Galileo RNSS receivers. These are detailed in section 9.

## ANNEX 1: AMSS REGULATIONS AND DEPLOYMENT IN SWITZERLAND

In 2019, Switzerland had 8570146 residents in an area of 41285 km<sup>2</sup>. In the frequency range 1240-1300 MHz, there are 41 unmanned amateur radio stations registered in OFCOM's database (see attached spreadsheet below). It is possible that other such facilities are in operation due to ancient permits. The database does not contain systems that were put into operation before 1998 and have not been changed since, or the changes have not been approved by OFCOM. However, the number of such systems is expected to be very small.

**Table 33: Unmanned amateur radio stations in Switzerland in the frequency range 1240-1300 MHz**

Unmanned Amateur Radio Stations	
Ratio of unmanned amateur radio stations to the total population	4.784·10 <sup>-6</sup> 4.8 per million residents
Unmanned amateur radio station density	1.0 per 1 000 km <sup>2</sup>

Unmanned stations are more or less in continuous operation, while manned stations only transmit sporadically. However, there is no database about the manned stations.



Parameters of  
Unmanned Amateur

In Switzerland, the frequency range 1240-1300 MHz is assigned to the amateur and amateur-satellite service on a secondary basis with the following additional restrictions:

- 1240-1260 MHz: Special permissions<sup>11</sup> are required. The use of this band by the amateur-satellite service is prohibited;
- 1260-1270 MHz: The use of this band by the amateur-satellite service is limited to the Earth-to-space direction (according to RR 5.282);
- 1270-1300 MHz: Special permissions<sup>11</sup> are required. The use of this band by the amateur-satellite service is prohibited.
- The maximum power of the amplifier is 1 000 W peak envelope power (PEP) in all cases. Amateur radio equipment sold in Switzerland has to be compliant to ETSI EN 301 783.

The amateur radio parameters cover a wide range. It is very difficult, if not impossible, to make statements about their distributions due to their non-normal and asymmetrical behaviour. Thus, descriptive statistics is more helpful. In Table 34, some of the content in OFCOM's database is summarised to "five-number summaries":

- the sample minimum (smallest observation);
- the first quartile (Q1) or 25<sup>th</sup> percentile;
- the median or 50<sup>th</sup> percentile;
- the third quartile (Q3) or 75<sup>th</sup> percentile;
- the sample maximum (largest observation).

<sup>11</sup>Authorisations in this frequency range are only granted on an individual basis after evaluation by OFCOM (CH).

**Table 34: Parameters of unmanned amateur radio stations in Switzerland in the frequency range 1240-1300 MHz**

Parameters of Unmanned Amateur Radio Stations in the Frequency Range 1240-1300 MHz	Min	Q1 (25th)	Median (50th)	Q3 (75th)	Max
Tx frequency [MHz]	1240.025	1 255.000	1 260.300	1 298.725	1 299.875
Rx frequency [MHz]	1240.025	1240.763	1270.750	1 294.100	1 299.600
Tx power [dBW]	-3.0	10.0	13.0	16.0	23.0
Antenna gain [dBi]	2.2	8.1	11.2	12.7	21.2
Losses [dB]	0.0	0.0	2.0	2.8	3.0
Bandwidth [kHz]	0.5	16.0	16.0	37.5	20 000.0
Height above ground [m]	2.0	7.5	12.0	20.0	50.0
Height above sea level [m]	257	739	946	1 464	3 574

Linear polarisations are mainly used, but occasionally circular polarisations can also be found. The information available on the antenna types used is only very general and can be seen in Table 35.

**Table 35: Antenna types of unmanned amateur radio stations in Switzerland in the frequency range 1240-1300 MHz**

Antenna Types of Unmanned Amateur Radio Stations in the Frequency Range 1240-1300 MHz	
Directional antennas	53.7%
Non-directional antennas	46.3%

OFCOM's database also contains information about the types of traffic modes used (Table 36).

**Table 36: Traffic modes of unmanned amateur radio stations in Switzerland in the frequency range 1240-1300 MHz**

Traffic Modes of Unmanned Amateur Radio Stations in the Frequency Range 1240-1300 MHz	
Semi-duplex	75.6%
Simplex	14.6%
Duplex	4.9%
Broadcast	4.9%

## ANNEX 2: PARAMETERS OF UNMANNED AMATEUR RADIO STATIONS IN GERMANY, FREQUENCY RANGE 1240-1300 MHz

### A2.1 NATIONAL OVERVIEW

At the end of 2019 Germany had 83 166 711 residents in an area of 357 582 km<sup>2</sup>. Approximately 64 000 citizens possess an amateur license (licenses for stations not included, as club stations, unmanned stations need a separate license) although only a small proportion of those amateurs will be active and transmitting in the band 1240-1300 MHz.

308 licences for automatic stations in the band 1240-1300 MHz existed at the end of July 2020. Several licenses may be issued for the same location, one for each transmitting station. Naturally, the frequency usage is spatially dense in areas where many people reside.

**Table 37: Unmanned amateur stations in Germany, frequency range 1240-1300 MHz**

Parameter	Value
Ratio of unmanned amateur radio stations to the total population	3,703 x 10 <sup>-6</sup>
Unmanned amateur station density	0,861 per 1000 km <sup>2</sup>

### A2.2 ASSIGNMENT PROCEDURES FOR UNMANNED STATIONS IN THE 23 CM RANGE

According to the regulations in Germany, any automated or remote-controlled station (unmanned station) of the amateur service has to be licensed. Each of those stations gets an individual callsign (on a single site, several stations can exist). On course of this assignment, a site-specific examination is done to check the availability of the assigned frequencies by the regulator, thus identifying and preventing interferences by co-/ or adjacent channel use (either by other amateur stations or other frequency users). Individual obligations can be made to ensure interference-free operation.

Following specific regulations apply:

- The responsible operator for unmanned controlled stations needs a license equivalent to the CEPT full-license.
- For unmanned controlled stations: maximum equivalent radiated power (ERP) of 15 W PEP.
- For manned stations: maximum equivalent radiated power (ERP) of 750 W PEP.
- Maximum occupied bandwidth is 2 MHz, except:
  - 7 MHz for television emissions, digital or amplitude modulated;
  - 18 MHz for television emissions, frequency modulated;
  - The term 'occupied bandwidth' refers to the 99% bandwidth.
- No unmanned operation in the frequency range 1247-1263 MHz.
- Maximum *e.i.r.p.* of 5 Watt in the frequency range 1247-1263 MHz (manned stations).
- Frequency range 1260-1270 MHz is allowed for amateur satellite service on a secondary basis (other secondary assignments have priority above the amateur satellite service), link direction: earth to space.

The frequencies are checked for conformance with the radio amateur's own band plan during the application phase; exceptions are only accepted in well-founded cases. In the case of ATV applications, the centre frequency affects the available bandwidth: while operation in the middle of the sub-band (1280 MHz) can be

granted with a bandwidth up to 16 MHz, on the centre frequency 1288 MHz one only applies for up to 8 MHz and on centre frequency 1291 MHz the operation is limited to a maximum bandwidth of 6 MHz.

The mandatory license for a new station is limited to one year. This gives some additional flexibility in case of issues. After the first year, the license holder can apply for a renewal of the license which is then given for three years. The licenses can be renewed on application.

### A2.3 STATIONS PARAMETERS

The following sections summarise the key parameters that can be derived from the electronic part of the database.

#### A2.3.1 Frequency band usage

The illustration in Figure 11 and the corresponding numbers in Table 38 show the distribution of amateur stations sorted by the sub-bands as given in the radio amateur’s band plan.

One can see that the most interest leans toward the band’s edge. Nonetheless, a certain interest can be noted in the sub-band for the digital links (1291.494-1296 MHz).

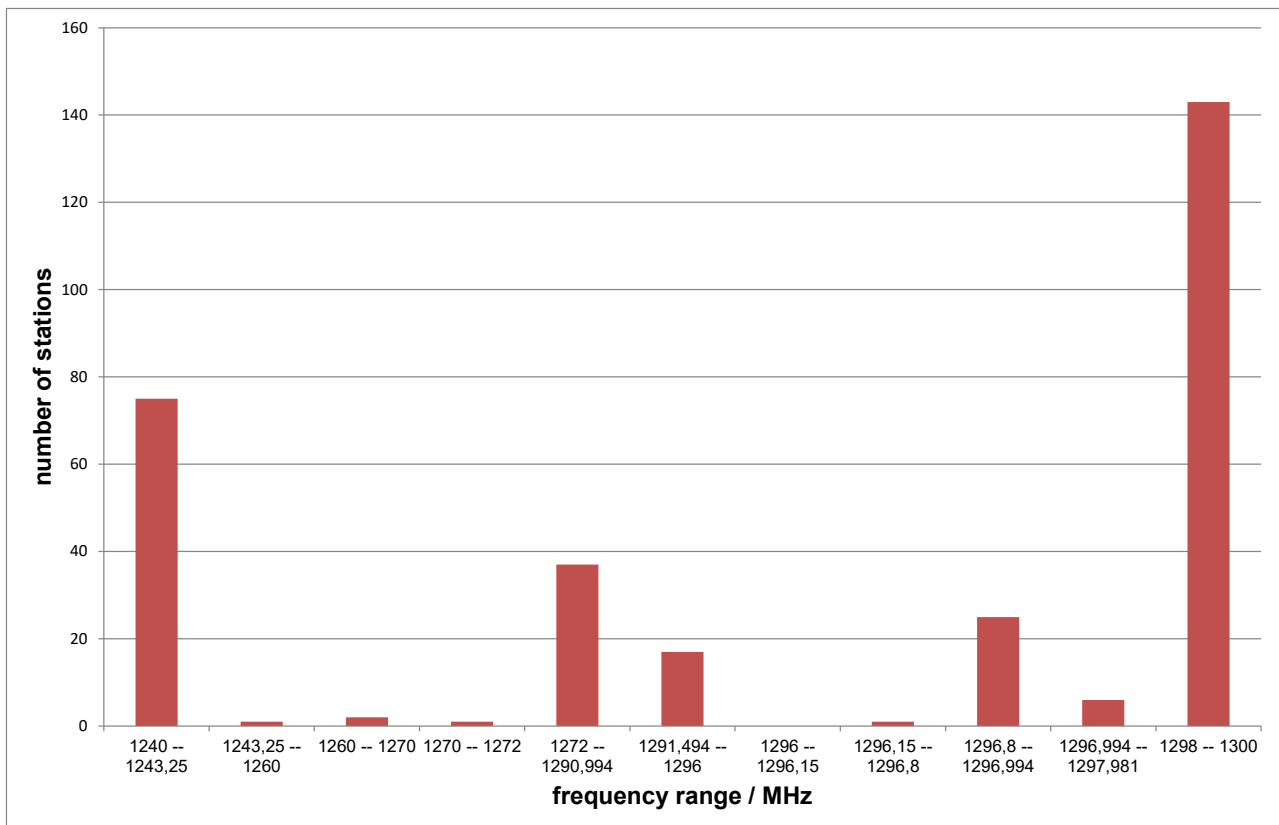

**Figure 11: Number of unmanned amateur stations grouped by sub-band in the 23 cm frequency range**

**Table 38: Number of unmanned station (frequency range 23 cm) grouped by frequency sub-band**

Frequency range / MHz	Count
1240-1243.25	75
1243.25-1260	1
1260-1270	2
1270-1272	1
1272-1290.994	37
1291.494-1296	17
1296-1296.15	0
1296.15-1296.8	1
1296.8-1296.994	25
1296.994-1297.981	6
1298-1300	143

**A2.3.2 Occupied bandwidth**

Another issue of interest is the occupied bandwidth. As already implicit stated by the frequency band usage, most stations focus on bandwidth conservative usages. The number show that more than 80% of the issued licenses have applied for up to 150 kHz. The data is given in Table 39 and illustrated in Figure 12.

**Table 39: Cumulative bandwidth distribution of unmanned amateur stations in the 23 cm range**

Bandwidth class / kHz	Count	Cumulated	Percentage
≤ 1	18	18	6%
1 ... 6.25	15	33	11%
6.25 ... 12,5	40	73	24%
12.5 ... 25	128	201	65%
25 ... 50	42	243	79%
50 ... 150	11	254	82%
150 ... 6000	18	272	88%
6000 ... 12000	12	284	92%
12000 ... 16000	24	308	100%

Note: the class 150 ... 6000 seems an odd choice, considering the huge frequency range involved. Actually, it contains: 1x250 kHz; 1x2000 kHz; 16x6000 kHz

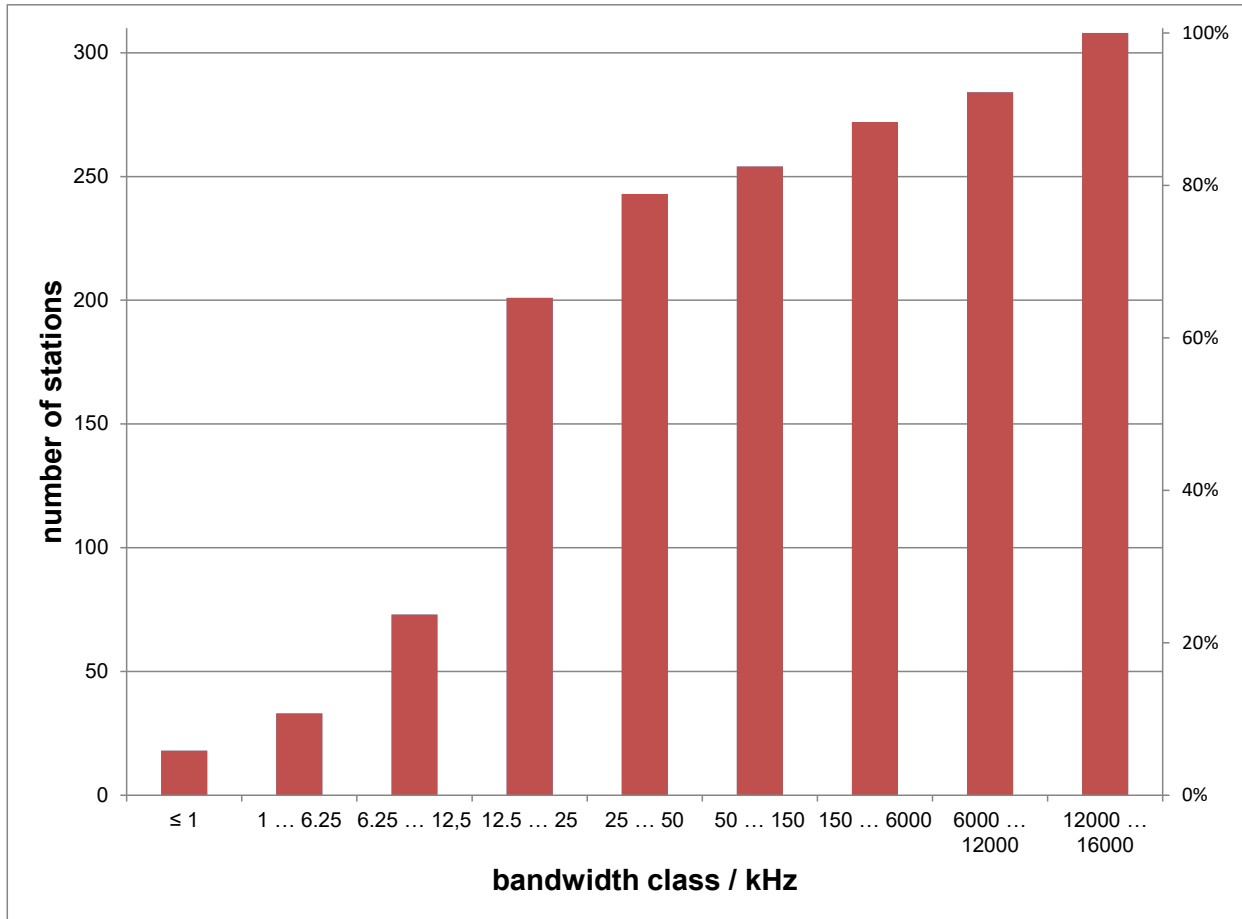

**Figure 12: Unmanned amateur stations, 23 cm frequency range: bandwidth distribution Licensed Equivalent radiated power**

The values for the equivalent radiated power (ERP) in dBW are summarised below. The majority of licensees (approx. 60%) have applied for the maximum ERP of 11,76 dBW (15 W).

**Table 40: unmanned amateur station, 23 cm frequency range: ERP distribution**

ERP range / dBW	Count
≤ 0	4
5	49
10	69
11.76	186

## ANNEX 3: A SURVEY OF THE NUMBER OF ACTIVE (TRANSMITTING) AMATEUR STATIONS USING THE BAND 1240-1300 MHZ AT THE BUSIEST TIMES IN SOME COUNTRIES WITHIN THE CEPT REGION

### A3.1 INTRODUCTION

As well as taking into account the technical parameters associated with the amateur transmitters, it will be key to consider the number and geographical spread of active amateur transmitters that could interfere with the Galileo service users at any specific time. Although there are many tens of thousands of licensed amateurs in most large European countries and many hundreds that take an interest or may be equipped for the 23 cm band, only a fraction of those are actively transmitting in the band at any one specific time.

This paper refers to published information and surveys the number of active transmitting stations recorded from the perspective of home and temporary portable simplex stations using narrowband and wideband modes. It does not deal with operation into repeater stations or the output signals from repeater stations (both narrowband and wideband ATV).

Readily available data from a number of CEPT countries has been consulted but of course stations are operational in all CEPT countries.

#### A3.1.1 Amateur Activity Periods in 1240-1300 MHz

In order to incentivise radio station development, regular national and regional contests and activity periods are organised throughout the year by the local national societies and interest groups. These activity periods are identified for narrowband terrestrial simplex communication applications as well as for more specialised activities like earth-moon-earth communications or broadband amateur TV.

These contest and activity periods attract by far the largest number of simultaneous users (and therefore transmissions) onto the 23cm band compared with other times when random transmissions might occur.

As contests require adjudication, the active station logs are submitted to a central source (usually the national radio society or contest organiser) and summaries are published in result tables. These summary tables can be consulted to estimate the number of active stations (and therefore transmitters) over the activity period.

#### A3.1.2 Narrowband Activity in the range 1296-1298 MHz

In many countries monthly activity periods are scheduled during a specific weekday evening usually lasting around 2.5 hours. In addition, there are two main Europe-wide contest sessions scheduled during the spring and autumn time that last for 24 hours. The results from these periods can be surveyed to identify the busiest sessions in order to evaluate the maximum number of stations active on the band.

Active stations during the busiest period in some CEPT countries:

**Table 41: Active stations during the busiest period in some CEPT countries**

Country	Active Stations
UK	100
Germany	139
France (note 1)	88-127
Italy	36
Netherlands	19
Switzerland	9
Note 1: Over each of the last 5 years. Power level data not available.	



However not every active station will submit their activity log for adjudication and by way of an example:

The 23 cm UK society contest manager reported that 155 different callsigns were active throughout 2019 at some point.

The Dutch society VHF manager indicated that 87 different callsigns were active during 2019 as a whole.

To be conservative the numbers in the table above could be increased by 50%.

### A3.1.3 Resources consulted

GB - <https://www.rsgbcc.org/cgi-bin/vhfresults.pl?Contest=1.3GHz%20UKAC&year=2019>

CH - <https://www.uska.ch/amateurfunkpraxis/contest/schweizer-contest-uhfvhf/>

IT - [http://www.ari.it/index.php?option=com\\_content&view=article&id=6051&Itemid=352&lang=it](http://www.ari.it/index.php?option=com_content&view=article&id=6051&Itemid=352&lang=it)

DE - <https://www.darc.de/der-club/referate/conteste/ukw-conteste-start/archiv-ukw-conteste/>

### A3.1.4 Earth-Moon-Earth (EME) Activity in the range 1296-1298 MHz

There are five major activity contest periods scheduled each year by interest groups in Europe, USA and Italy. Each scheduled period is 24 hours although the moon will only be visible for around 15 hours from any single location.

Again, these activity periods are the focus for activity and result in the busiest times on the band.

Active 23 cm EME stations in the CEPT countries represented in the results:

**Table 42: Active 23cm EME stations in the CEPT countries**

Country	Active Stations
Czech Republic	5
Sweden	5
Germany	4
France / Italy/ Poland	3 each
+ 8 more countries	1 each

In total 38 active stations across the CEPT region are noted for the specific event analysed. In addition, another 19 stations across the CEPT region are noted as “multiband”. These stations will be active on frequencies in the lower VHF and UHF ranges as well as the 23 cm band.

### A3.1.5 Resource

<https://contests.arrl.org/ContestResults/2018/EME-2018-FinalFullResults.pdf>

### A3.1.6 Wide Band Activity (ATV) around 1260 MHz

There is one major regional activity contest period scheduled each year by the amateur TV community in Europe. This is a 30-hour event over a weekend. In addition, some national societies organise scheduled activity weekends once a month.

Again, these activity periods are the focus for activity and represent the busiest times on the band.

Recorded number of active stations by CEPT country:

**Table 43: Recorded number of active stations by CEPT country**

Country	Active Stations
Italy	24
Netherlands	24
UK	15
Sweden	5
Spain	4
France / Germany	2 each
Switzerland	1

In total, 77 active stations across the CEPT region are noted for the 30 hours regional activity contest. Using UK as an example, the published results show that 8 of the 15 active stations were temporary “portable” stations.

#### **A3.1.7 Resource**

[IARU Region 1 ATV Contest 2018 Results \(batc.org.uk\)](http://batc.org.uk)

## **ANNEX 4: AMATEUR RADIO REPEATER AND BEACON STATIONS USING THE BAND 1240-1300 MHZ IN SOME COUNTRIES WITHIN THE CEPT REGION-MAY 2020**

The IARU consulted the national amateur radio society VHF/Microwave Managers in a sample of CEPT countries for national information about the number of repeater and beacon stations assigned frequencies in the band 1240-1300 MHz.

This annex presents that information against the backdrop of the IARU Region 1 band plan [27].

### **A4.1 AMATEUR RADIO REPEATER AND BEACON STATIONS**

As well as individual radio amateur stations the band 1240-1300 MHz is also occupied by stations operating as repeaters or beacons. These are always individually licensed for a particular location and operating frequency. Their assignment is coordinated on a national basis. In general, a repeater station is established at an advantageous radio location to receive surrounding less well sited individual stations on a specific input frequency and relay (i.e. re-transmit) their traffic on an alternative specific output frequency from the better site. This increases the range for less well-sited individual stations. Repeaters may relay voice, amateur TV or data traffic. Voice and TV repeaters might carry either analogue or digital traffic.

Beacons are established for the purposes of monitoring propagation conditions in the band and providing a reliable off-air signal for test purposes.

### **A4.2 LICENSING AND ASSIGNMENT PROCEDURES**

Repeater or beacon stations are usually licensed in their own right as an extension or addition to a specific radio amateur's personal licence who then becomes the designated "keeper" for that station acting as the official point of contact. Importantly, the keeper (and designated deputies) has the responsibility to close down the transmitting station in a timely manner at the request of the authorities. Repeater station assignments are co-ordinated within the amateur service at a national level by the interested amateur parties usually before the application for a licence is submitted to the national regulatory body. Propagation beacons may additionally be co-ordinated regionally.

National regulatory bodies are often responsible for co-ordinating a licence application with other primary service spectrum users in the band with whom the amateur service is already sharing. This can lead to departures from the generic IARU band plan to take account of other national spectrum services.

### **A4.3 VOICE AND DATA REPEATERS**

Repeater stations generally operate in a paired frequency duplex mode. There is an input frequency for the receiver and an output frequency for the transmitter. When not relaying traffic (in stand-by) the repeater output is silent apart from a periodic identification signal. However, some stations do revert to a beacon mode when in stand-by. The transmitter is usually activated on receipt of an appropriate signal on the repeater input frequency. Other features can include "watch-dog" timers to time-out the transmissions if a signal persists on the input channel for longer than a specified time (usually a few minutes at the most).

The legacy analogue voice narrowband FM mode remains common but digital mode usage is expanding. Certain manufacturers and other groups have developed a small number of digital voice modes with varying degrees of popularity. For the 23 cm band the most common mode is 'D-STAR' (voice at 4800bps MSK) ([2]). Other modes are DMR [3] and Fusion [4] but these two were not evident in the survey sample.

#### **A4.3.1 Repeater frequencies in 1240-1300 MHz**

The IARU R1 band plan includes the following sub-bands (identified here as sub-bands 'a' to 'f') that may be used for repeater operation. Not all frequencies are assigned in every country and the actual frequencies assigned can vary on a national basis.

All Mode (max bandwidth 20 kHz):

Sub-Band a

- 1242.025-1242.700 MHz Repeater output, ch. RS1-RS28 paired with:
- 1270.025-1270.700 MHz Repeater input, ch. RS1 -- RS28

Sub-Band b

- 1242.725-1243.250 MHz Digital communications, ch.RS29 - RS50 paired with:
- 1270.725-1271.250 MHz Digital communication, ch.RS29 – RS50

Sub-Band c

- 1293.150-1294.350 MHz Repeater input, paired with:
- 1258.150-1259.350 MHz Repeater output, ch.R20 - R68

FM Voice / Digital Voice (max bandwidth 20kHz with 25 kHz channel spacing):

Sub-Band d

- Repeater input – ch.RM0 (1291.000 MHz) - RM19 (1291.475 MHz) paired with:
- Repeater output – ch.RM0 (1297.000 MHz) - RM19 (1297.475 MHz)

Additionally - All Mode, General mixed analogue or digital use in 25 kHz channels:

Sub-band e

- 1298.025 MHz (RS1) to 1298.975 MHz (RS39)

#### **A4.3.2 Data Repeater frequencies**

Amateur non-voice data 'Packet Radio' modes operate through narrow bandwidth traffic nodes and repeaters having similar bandwidth requirements to voice repeater stations. The digital voice mode 'D-STAR' has an associated 'DD mode' for higher rate data traffic (128kbs - TDD) that requires a single wider channel of 150 kHz.

The IARU band plan includes these options in different sub-bands in the 'all mode' section from 1298 MHz to 1300 MHz for digital mode usage depending on bandwidth.

Sub-band f

- 1298.000 MHz to 1299.000MHz in 25 kHz channels;
- 1299.000 MHz to 1299.750 MHz in 150 kHz channels;
- 1299.750 MHz to 1300.000 MHz in 25 kHz channels.

#### **A4.3.3 Voice and Data Repeater assignments – a survey of some CEPT countries**

The data in the table below summarises the information received from a sample of IARU Region 1 VHF managers on the number of voice and data repeater stations licensed to operate in the IARU band plan repeater sub-bands in a number of countries. Whether the repeater stations are actually in-service at the time of the survey would require deeper analysis.

**Table 44: Voice and Data Repeater assignments – in some CEPT countries**

Sub-Band	Voice and Data Repeaters											
	a		B		c		d		e		f	
Direction (Note 1)	Tx	Rx	Tx	Rx	Tx	Rx	Tx	Rx	Tx	Rx	Tx	Rx
Belgium	-	4	-	-	-	-	1	1	4	-	3	3
Denmark	-	-	-	-	-	-	4	4	-	-	-	-
France	-	1	-	-	-	-	5	5	-	-	2	2
Italy (note 2)	4	12	-	-	-	-	35	18	-	-	-	-
Netherlands (note 3 and note 4)	3	11	1	-	-	-	-	-	13	-	2	2
Switzerland (note 5 and note 6)	-	3	1	2	6	7	-	-	4	-	9	7
UK	-	-	-	-	-	-	9	9	-	-	-	-

Note 1: Direction: Tx indicates a repeater transmitting output frequency and Direction Rx indicates a repeater receive input frequency

Note 2: Two voice repeaters are transmitting on the input frequency in sub-band a (Rx) not in alignment with the IARU plan. One voice repeater is transmitting in 1258.900 MHz, not aligned with the IARU band plan

Note 3: National database doesn't indicate the input receiving frequency or the duplex split. Online resources for the specific repeater stations consulted. Four remain unknown

Note 4: In addition two repeaters receive in channels above 1297.700 MHz

Note 5: Source ANNEX 1.

Note 6: In addition seven repeaters are transmitting and eight are receiving on frequencies that are at variance with the IARU band plan including the 'All Mode' sections, the satellite section and the beacon section

## A4.4 AMATEUR TV (ATV) REPEATERS

### A4.4.1 ATV Repeater frequencies in 1240-1300MHz

The IARU R1 band plan identifies the following sub-bands for analogue and digital TV repeaters. Not all frequencies are assigned in every country and the actual usage varies on a national basis:

- 1243.250 -1260.000 MHz - Identified here as 'Sub-band a';
- 1272.000 -1290.994 MHz - Identified here as 'Sub-band b'.

In some cases, for national reasons, frequencies outside these ranges may be assigned for ATV repeater operation.

### A4.4.2 Repeater Architecture

There is no standard TV repeater station and the architecture complexity and mode(s) of operation (e.g analogue or digital standard) are a free choice for the station proposer (unless prohibited by national licence conditions). The features can be chosen to support the interests of local groups of amateur station operators. However, the licence might reflect the technology choice in which case regulatory action might be needed if the mode of operation is changed.

An ATV repeater station may exhibit any of the following operational characteristics and features:

- Input and output frequencies that are either in-band or cross-band with input or output frequencies in other bands (e.g. commonly 2.3 GHz or 10 GHz);
- The repeater station may have more than one input frequency and more than one output frequency;
- Older technology analogue ATV repeaters employ frequency modulation;
- Analogue TV repeaters are assigned a wider bandwidth channel – usually 12 to 16 MHz;
- Newer technology digital ATV repeaters are usually based on adaptations of commercially standardised air interfaces (see trends below);
- Digital TV repeaters are assigned narrower channels as low as 6 or 8 MHz;
- The repeater station may handle only analogue TV signals or digital TV signals (or both);
- The repeater may re-modulate analogue TV signals onto a digital carrier;
- The repeater may support control functions (e.g. access request, output mode...) signalled in other frequency bands (e.g. VHF amateur bands);
- The repeater station may be flexible to handle various digital TV modes (e.g. symbol rate, coding, error correction etc.);
- The repeater may operate in a beacon mode when not in use (e.g. a test card or video loop);
- The repeater may be completely de-activated when activity is unlikely (e.g. overnight) to reduce power consumption.

#### **A4.4.3 Repeater Trends**

Legacy analogue TV repeaters continue to operate but modern installations deploy spectrally efficient digital TV repeaters transmitting DVB-S/MPEG-2 signals (usually 2Msym/sec or 4Msym/sec). This is actively encouraged by the most forward-looking national interest groups who work hard to develop the appropriate hardware and operating practices. Use of these air interfaces reduces the transmission bandwidth and improves the inter-service co-ordination potential. Further experimentation continues to increase the spectrum efficiency of amateur TV signals and it has been shown possible to transmit HD MPEG-4 signals with symbol rates less than 333kSym/sec in a reduced bandwidth (500 kHz).

#### **A4.4.4 Repeater Assignments – a survey of some CEPT countries**

The data in the table below summarises the information received from a sample of IARU Region 1 VHF managers on the number of ATV repeater stations licensed to operate in the ATV repeater sub-bands identified in the IARU band plan for a sample of CEPT countries. Whether the repeater stations are actually in-service at the time of survey would require deeper analysis.

**Table 45: ATV Repeater Assignments in some CEPT countries**

Sub-Band	ATV Repeaters			
	a		b	
	Tx	Rx	Tx	Rx
Belgium	-	5	6	3
Denmark	-	-	-	-
France	20	1	4	5
Germany (note 2 and note 3)	-	N/K	53	N/K
Italy (note 4)	11	1	-	1
Netherlands	1	4	8	1
Switzerland	4	1	2	-
UK (note 5)	-	21	-	4

Note 1: Direction Tx indicates a repeater transmitting output frequency and Direction Rx indicates a repeater receive input frequency  
Note 2: In Germany 16 digital ATV repeaters are transmitting on a centre frequency of 1291 MHz and these are included in "sub-band b"  
Note 3: Receiver input frequencies not provided in data.  
Note 4: In addition, seven TV repeaters are transmitting between 1240 MHz and 1243 MHz just below sub-band a and one is transmitting at 1267 MHz between sub-bands a and b. Ten TV repeaters are receiving just below sub-band a in 1240- 1243 MHz.  
Note 5: In the UK there are 25 TV repeaters transmitting outside the band between 1304 MHz and 1322 MHz. This is a national agreement.

## A4.5 PROPAGATION BEACONS

### A4.5.1 Propagation Beacon Frequencies in 1240-1300 MHz

Propagation beacons are built and installed at a remote location by radio amateurs to provide stable and accurate off-air signal sources for receiver system testing and importantly to provide an indication of the radio propagation conditions over longer paths. The beacon might be installed to operate with an omni-directional or directional antenna. Usually, the beacon emits a narrowband continuous wave signal with an identification (call sign) and location information message repeated on a regular basis using closely spaced FSK. In some cases, amateur digital mode signals are employed enabling automated monitoring of the beacon reception. Most beacons are transmitting continuously.

The IARU R1 band plan identifies the following frequency sub-bands for propagation beacons:

- 1296.750-1296.800 Local Beacon (10 W ERP max.);
- 1296.800 – 1296.994 Beacons exclusive.

The data in the table below summarises the number of beacon stations licensed to operate in the IARU band plan propagation beacon sub-bands for a sample of CEPT countries.

**Table 46: Beacon Station Numbers in some CEPT countries**

	Beacons
Belgium	5
Denmark	3
France	15
Germany	20
Italy	13
Netherlands	4
Switzerland	2
UK	11

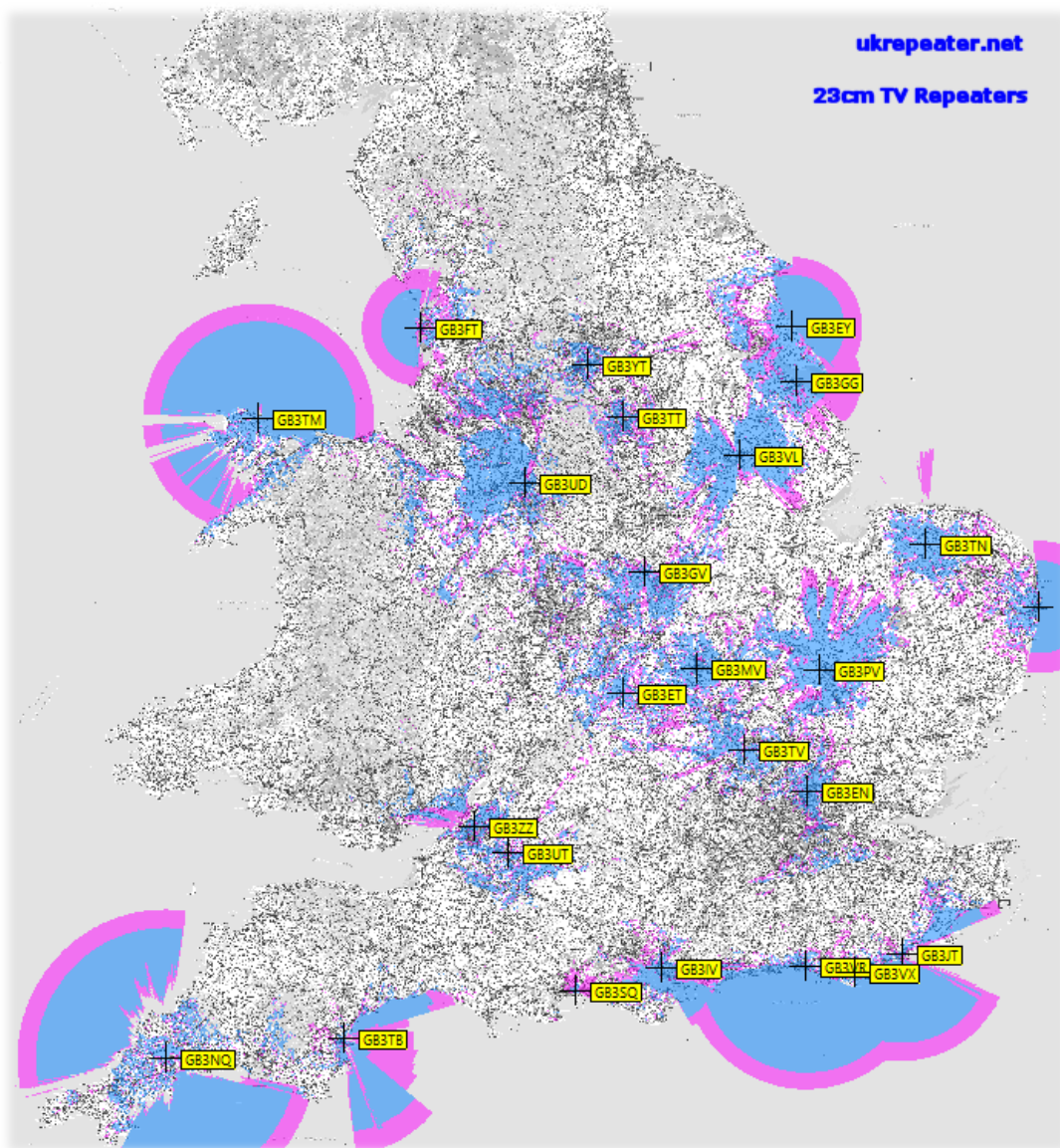

**Figure 13: An example coverage map for 23 cm band ATV Repeaters in the UK**



## ANNEX 5: MEASUREMENTS MADE IN GERMANY

### A5.1 METHODOLOGY AND MEASUREMENT SETUP

Galileo E6 was represented by a constellation of ten E6 signals. One signal served as the victim while the other nine were considered as system internal noise, as they are discriminate by the spreading codes within the receiver.

Instead of performing go/no-go tests to a given threshold, the measurements were performed parametrically by applying a wider range of RFI power level while measuring the decrease of the post-correlation  $C/N_0$  of the used GNSS receiver.

The measurement setup is shown in Figure 14. One can see two separate signal paths, one for the Galileo E6-B/C signal and one for the currently tested amateur radio signal. The RFI signals were applied separately, one after the other. Victim and interfering signals from both sides are added at controlled power level and fed into the GNSS receiver.

All receiver input signals are also available to a set of monitoring and measurement equipment (devices 11, 12 and 13). The receiver, like all other active elements in the test set-up, except the RSA (device 11), are interconnected and controlled via LAN. Some test cases include a special Interference Suppression Unit (ISU, device number 24) which is then inserted in front of the GNSS receivers' input. Precision step attenuators in both paths enable controlled setting of signal levels. This concept was preferred as it assures reproducible test conditions of the RF power levels. This allowed to compensate the power loss due to the ISU insertion, making sure that the victim receiver is always supplied with the same  $C/N_0$ .

The amateur radio equipment was located in a separate room about 10 m apart from the laboratory hosting the GNSS test set-up. All parts involved in the generation of the amateur radio signals were real life devices (no measurement signal generators involved). All signals were delivered to the main measurements room via high performance coaxial cables to enable unambiguous RF power level conditions at the GNSS receiver input. This separation proofed successfully the rejection of radiation that was measurable in the close vicinity of some transmitters.

Details on each source of amateur signals are provided in [4]. A commercial GNSS simulator generates 10 Galileo E6-B/C-signals and 10 GPS-L1-C/A signals. The GPS L1-signal is used as a time marker. The simulator also adds controlled noise to simulate a defined  $C/N_0$ -condition in the GNSS receiver.

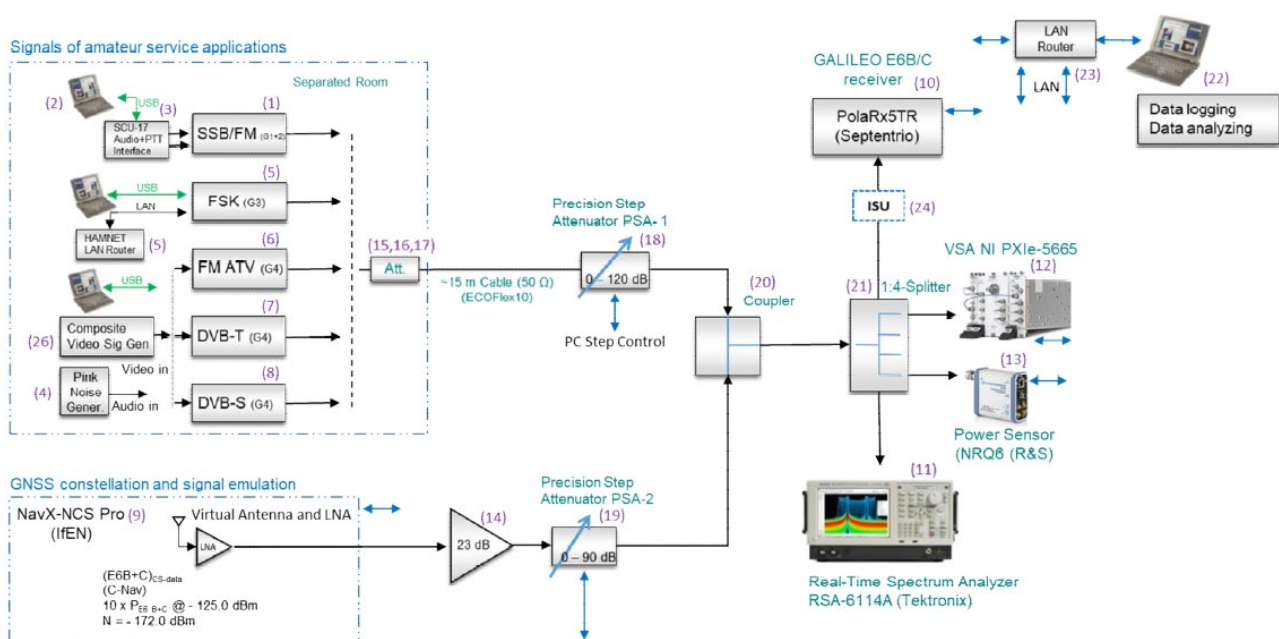

Figure 14: Measurement setup

The scenario is as follows: the GNSS signal path is levelled in such a way that a  $C/N_0$  at the receiver's output of about 45 dBHz is achieved. The power and noise levels within the signal chain are measured. Changes to the levels in the GNSS signal path were only done via the corresponding step attenuator (noise level in that chain is dominated by the GNSS simulator and the line driver amplifier (device number 14) to maintain a constant  $C/N_0$  at the RF domain.

For each amateur signal, the full level at the lowest setting of the step attenuator in the amateur path (device number 18) was measured. Afterwards, the interfering level was set via the step attenuator only. This keeps the relation of the signal and the generated noise and unwanted emissions (spurious resp. out of Band domain) for any power level fed to the victim receiver. Device number 15 to 17 was applied to limit the max. power offered to the precision step attenuator.

The measurement procedure was as follows: the receiver was allowed to settle with the wanted signal active only. Then, a strong level from the unwanted signal was applied to enforce a strong dip in the  $C/N_0$  at the receiver; the interferer was disabled again for a few seconds (allowing the receiver to settle again) and finally the interferer was slowly ramped up in power. During the testing time, the  $C/N_0$ -values were logged, synchronized with the attenuator settings in the interfering signal path.

For any major type of radio amateur signal, a test case investigating the worst-case conditions was performed, where the amateur radio signal was placed on the E6-centre frequency (as long as long as the device allowed that setting). Furthermore, frequency offsets as low as possible (according to the IARU band plan) were introduced.

## A5.2 MEASUREMENT EVALUATION

Each test case produced files originally created by the receiver's internal measurement feature that were exported to a RINEX file. An evaluation tool transforms the  $C/N_0$  vs. time information of the PSA steps into a representation of  $C/N_0$  vs. the absolute power values at the input of a 0 dBi GNSS-antenna.

The mapping from the receiver input to the input of a 0 dBi antenna is as follows: Given the noise level  $N_{BW_{Noise}}$  in the E6-signal's system bandwidth  $BW_{Noise}$  of 40.92 MHz and an assumed noise figure of the active receive antenna  $(NF_{Ant})_{dB}$  of 2 dB, the gain of the antenna  $(G_{Ant})_{dB}$  can be derived from the thermal noise level (-174 dBm/Hz). This gain is also applied to the amateur radio signal level, resulting in the level at the input of a 0 dBi antenna.

$$(G_{Ant})_{dB} = N_{BW_{Noise}} - 10 \cdot \log_{10}(BW_{Noise}) - (-174dBm/Hz + (NF_{Ant})_{dB})$$

The evaluations also include a modelled result curve according to the equation of [10] [p.556], where the interference resistance factor Q has been chosen in such a way to smooth the model's result close to the measured values.

$$\left(\frac{C_S}{N_0}\right)_{eff} = \frac{1}{\frac{1}{\frac{C_S}{N_0}} + \frac{C_I}{QR_C}}$$

## A5.3 TEST CASES AND MEASUREMENT RESULTS

There is a huge variety of radio amateur applications as indicated in section 2.1. For that, a pre-selection process categorised the emissions into four Groups, representing the diversity of all potential RF emissions:

- G1: signal bandwidth < 1 kHz (Morse, SSB voice);
- G2: signal bandwidth up to 15 kHz (FM voice);
- G3: signal bandwidth up to 200 kHz (high speed data);
- G4: signal bandwidth 1 ... 16 MHz (Amateur TV);

### A5.3.1 Test case overview

The test cases were chosen in such a way that all available amateur signal groups were used. The carrier frequencies were varied to measure at least (if possible) the interfering signal on the Galileo E6-centre frequency (worst case scenario) and with the least possible frequency separation from the E6-centre frequency, if IARU's band plan for Region 1 is respected (bound to the transmitter's available channel selection options).

Table 47 gives an overview of all measurements performed. Within the table, the columns have the following meaning:

Group: indicates the group of emission classes the interfering signal belongs to.

Topic: contains a short description of the test's settings.

Interfering freq.: centre frequency of the amateur radio signal, in MHz

Offset from E6-centre: the difference between the amateur radio signal's centre frequency and the E6-centre frequency, in MHz.

Level type (amateur radio): refers to the detector/measurement type used in measuring the RFI at 0 dB attenuation.

**Table 47: Measurements Galileo E6 vs. amateur radio - overview of test cases performed**

Group	Topic	Interfering freq./MHz	Offset from E6-centre/MHz	Level type (amateur radio)
1	Morse, IARU band plan	1296.20	17.45	PEP
1	Morse, centre frequency	1278.75	0.00	PEP
1	SSB voice, IARU band plan	1296.20	17.45	PEP
1	SSB voice, centre frequency	1278.75	0.00	PEP
1	SSB voice, centre frequency, ISU mitigation	1278.75	0.00	PEP
2	FM voice, IARU band plan	1297.50	18.75	PEP
2	FM voice, centre frequency	1278.75	0.00	PEP
2	FM voice, centre frequency, AIM+ filter	1278.75	0.00	PEP
2	FM voice, centre frequency, ISU mitigation	1278.75	0.00	PEP
3	FSK 128 kbps, IARU band plan	1299.21	20.46	PEP
3	FSK 128 kbps, centre frequency	1278.75	0.00	PEP
3	FSK 128 kbps, centre frequency ISU mitigation	1278.75	0.00	PEP
4	FM-ATV, IARU band plan	1280.00	1.25	PEP
4	DVB-T 1, IARU band plan	1288.00	9.25	RMS
4	DVB-T 1 MHz, centre frequency	1278.75	0.00	RMS
4	DVB-T 1 MHz, centre frequency, ISU mitigation	1278.75	0.00	RMS

Group	Topic	Interfering freq./MHz	Offset from E6-centre/MHz	Level type (amateur radio)
4	DVB-T 4 MHz, IARU frequency	1286.00	7.25	RMS
4	DVB-T 4 MHz, centre frequency	1278.75	0.00	RMS
4	DVB-S 6 MHz, centre frequency	1278.75	0.00	RMS
4	DVB-T 1 MHz, frequency sweep	various	various	RMS
4	DVB-T 1 MHz, centre frequency	1278.75	0.00	RMS

### A5.3.2 Measurement results

The following sections detail the result for the individual test case, sorted by the interfering signal. In any section, two plots are given - one that shows the total test result over the whole RFI power tested and a second one that concentrates on the  $C/N_0$  degradation in a range of -5 ... 0 dB/Hz relative to the 45 dB/Hz baseline. The figures relate the  $C/N_0$  as reported by the victim receiver to the interfering power supplied by the output of an 0 dBi antenna. The relationship between the power supplied to the receiver's input port and the equivalent power at the reference antenna is given above.

#### A5.3.2.1 Morse (Test Cases G1-03, G1-04)

The results for the Morse signal are shown in Figure 15. The  $C/N_0$  plots indicate strong variations. It can be seen that a frequency separation of 17.45 MHz from the centre frequency relaxes the  $C/N_0$ -degradation by approx. 30 dB. Figure 16 shows the changes in  $C/N_0$  relative to a reference of 45 dBHz. Table 48 shows that at a  $C/N_0$  degradation of 1dB, an additional e.g. 0.5 dB increases the margin of interference power by 2 dB.

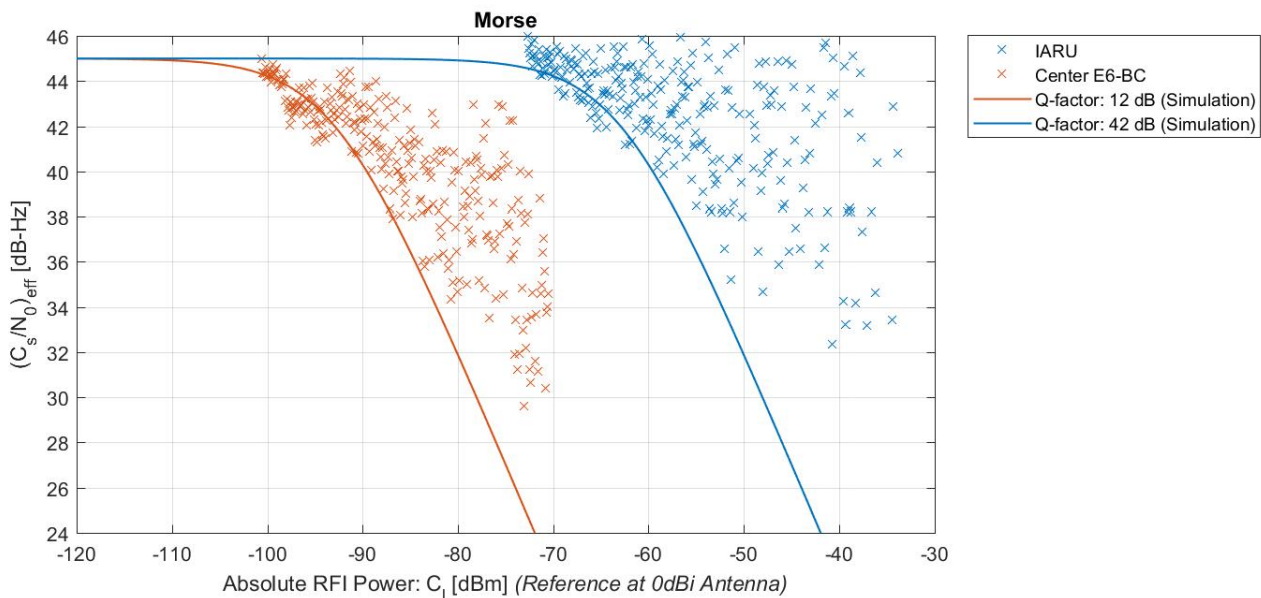
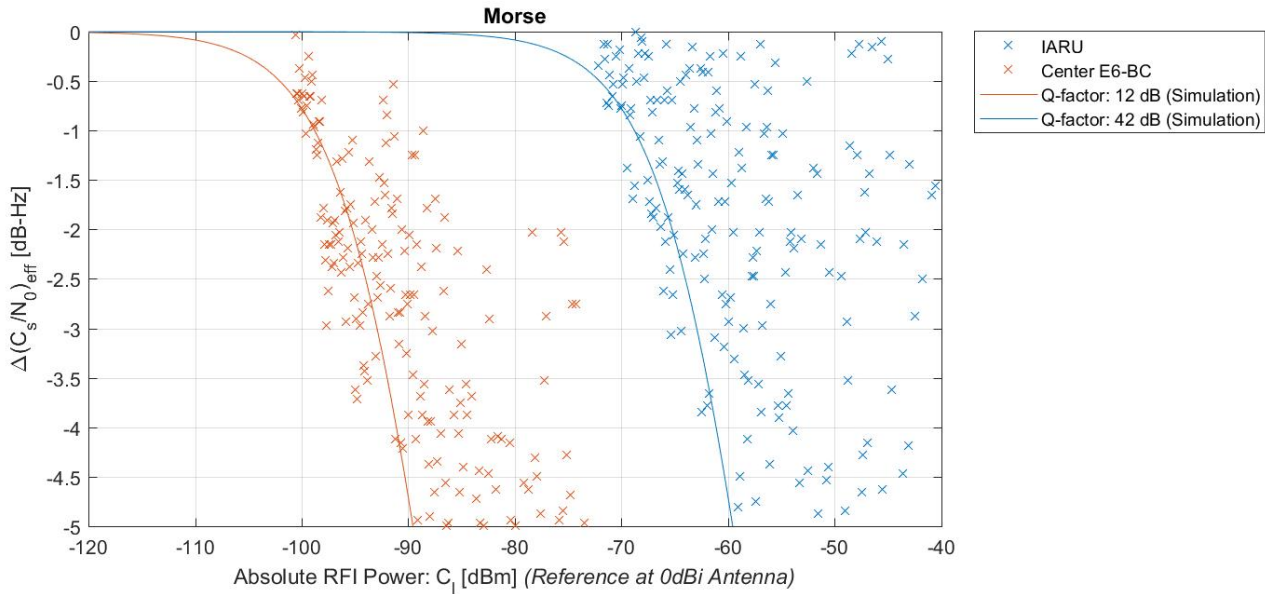

Figure 15: Processed results summary for Morse signal



**Figure 16: Result summary showing C/N<sub>0</sub> changes relative to 45 dB/Hz for Morse signal**

**Table 48: Key values for Morse signal: maximum signal power at 0 dBi antenna to certain C/N<sub>0</sub> degradation allowance**

$\Delta C/N_0$	Morse 1296.20 MHz	Morse 1278.75 MHz	Morse 1278.75 MHz with ISU
-1 dB	-68.8 dBm	-98.8 dBm	N/A
-1.5 dB	-66.7 dBm	-96.8 dBm	N/A
-5 dB	-59.6 dBm	-89.6 dBm	N/A
Q-factor	42 dB	12 dB	N/A

**A5.3.2.2 SSB voice (Test Cases G1-07, G1-08, G1-13)**

The results for the SSB voice signal are shown in Figure 17. Figure 18 shows the changes in C/N<sub>0</sub> relative to a reference of 45 dB/Hz. It can be seen that a frequency separation of 17.45 MHz away from the centre frequency relaxes the C/N<sub>0</sub>-degradation by almost approx. 40 dB. If the ISU is not inserted in the centre frequency scenario, the C/N<sub>0</sub> degrades fast.

Table 49 shows that at a C/N<sub>0</sub> degradation of 1dB, an additional e.g. 0.5 dB increases the margin of interference power by 2 dB.

Furthermore, the significant improvement by the ISU is clearly visible: although the ISU has to mitigate the RFI on Galileo’s E6 centre frequency, it allows even more interference signal power than in the offset frequency case where the ISU is not inserted. Considering that the SSB signal has a certain similarity to the Morse signal (both are narrowband, “pulse-type” emissions; but the amplitude variations in the signal envelope differ) the ISU produces a significant improvement on RFI mitigation.

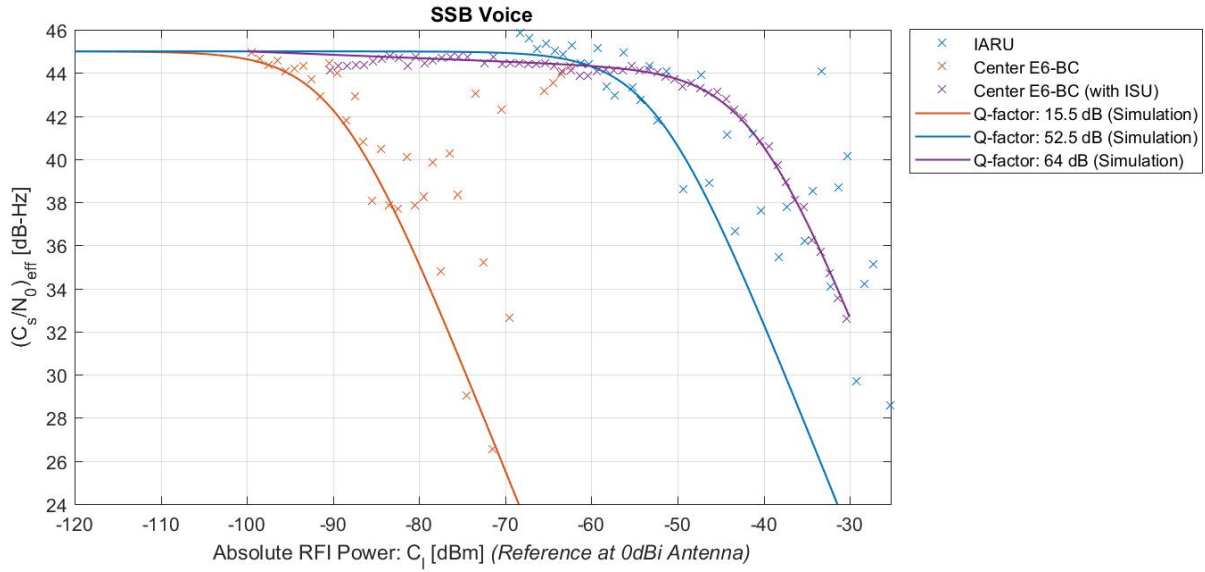

Figure 17: Result summary for SSB voice signal

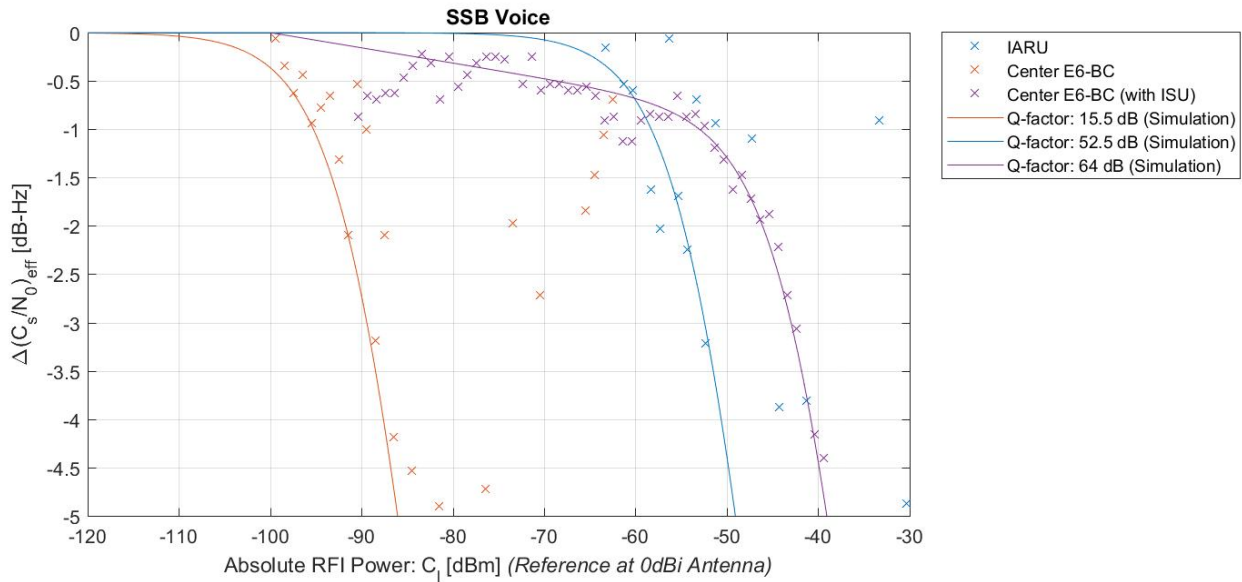

Figure 18: Result summary showing C/N<sub>0</sub> changes relative to 45 dB/Hz for SSB voice signal

Table 49: Key values for SSB voice signal: maximum signal power at 0 dBi antenna to certain C/N<sub>0</sub> degradation allowance

$\Delta C/N_0$	SSB voice 1296.20 MHz	SSB voice 1278.75 MHz	SSB voice 1278.75 MHz with ISU
-1 dB	-58.3 dBm	-95.3 dBm	-53 dBm
-1.5 dB	-56.3 dBm	-93.3 dBm	-48.6 dBm
-5 dB	-49.1 dBm	-86.1 dBm	-39.1 dBm
Q-factor	52.5 dB	15.5 dB	64 dB

**A5.3.2.3 FM voice (Test Cases G2-03, G2-04, G2-04 w/WB, G2-05)**

The results for the FM voice signal are shown in Figure 19. Figure 20 shows the changes in  $C/N_0$  relative to a reference of 45 dB/Hz. Apparently, a frequency offset of 18.75 MHz from the centre frequency improves the  $C/N_0$ -degradation by more than 40 dB.

No difference can be seen between the receiver operated with and without the receiver’s built-in AIM+ mitigation.

The ISU compensates the interfering signal on the centre frequency at least as good as a frequency offset from the centre frequency, i.e. operates on frequencies in accordance with IARU Band plan.

Table 50 shows that at a  $C/N_0$  degradation of 1 dB, an additional e.g. 0.5 dB increases the margin of interference power by 2 dB.

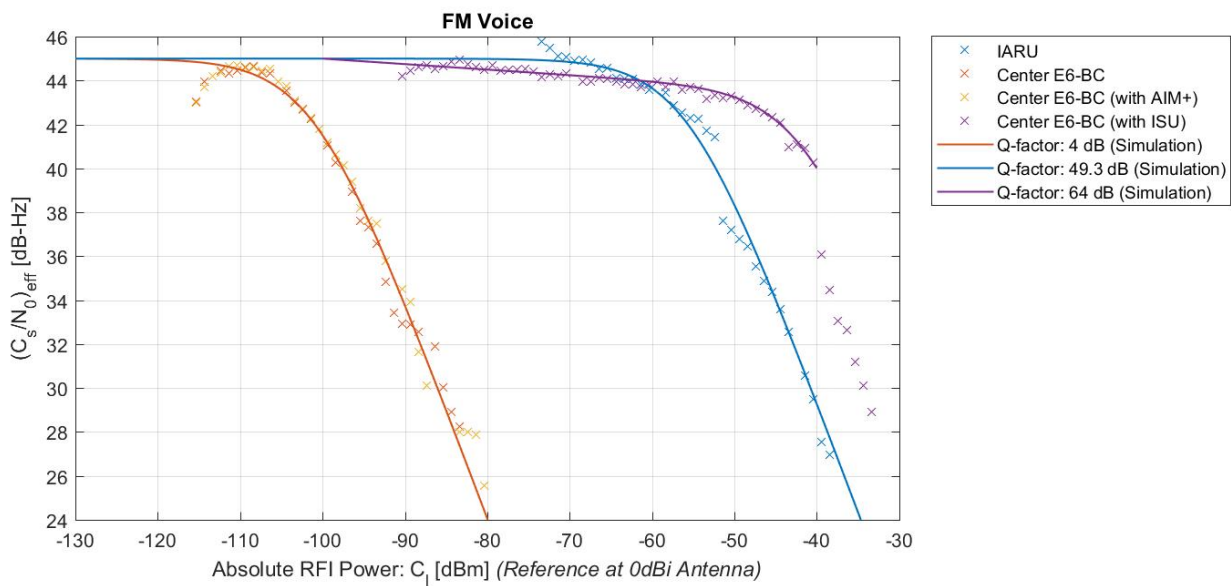

**Figure 19: Result summary for FM voice signal**

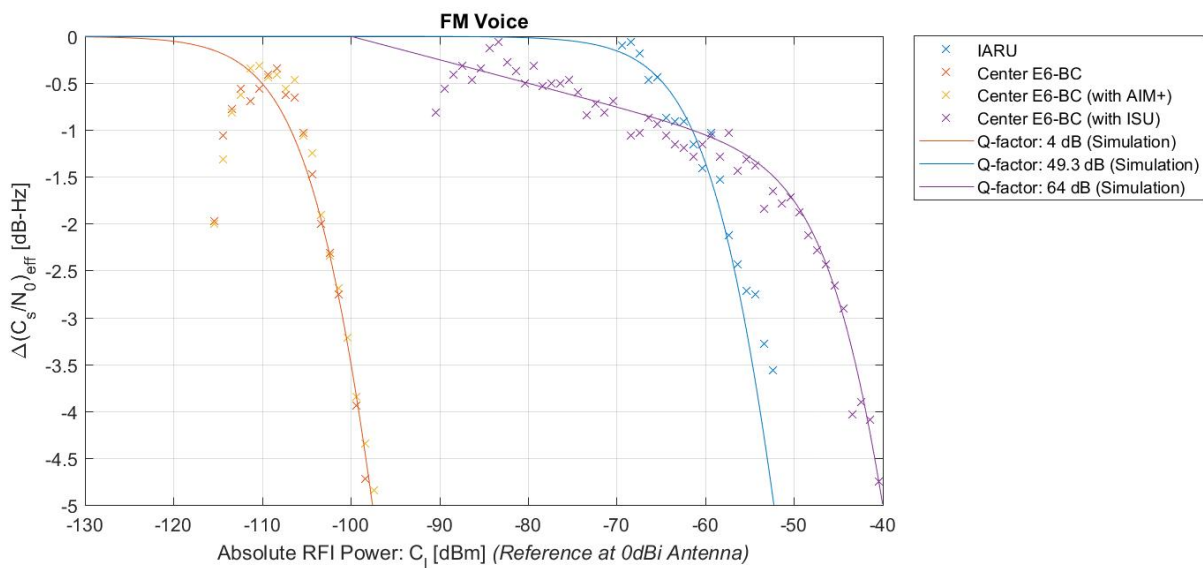

**Figure 20: Result summary showing  $C/N_0$  changes relative to 45 dB/Hz for FM voice signal**

**Table 50: Key values for FM voice signal: maximum signal power at 0 dBi antenna to certain C/N<sub>0</sub> degradation allowance**

$\Delta C/N_0$	FM voice 1297.50 MHz	FM voice 1278.75 MHz	FM voice 1278.75 MHz with ISU
-1 dB	-61.5 dBm	-106.8 dBm	-61.5 dBm
-1.5 dB	-59.5 dBm	-104.8 dBm	-52.2 dBm
-5 dB	-52.2 dBm	-97.6 dBm	-40 dBm
Q-factor	49.3 dB	4 dB	64 dB

**A5.3.2.4 FSK 128 kbps (Test Cases G3-03, G3-04, G3-06)**

The results for the FSK are shown in Figure 21. Figure 22 shows the changes in C/N<sub>0</sub> relative to a reference of 45 dB/Hz. A frequency separation of 20.46 MHz off the centre frequency improves the C/N<sub>0</sub>-degradation by more than 50 dB. The ISU compensates the interfering signal on the centre frequency almost as good as compared to the signal operated with an offset from the centre frequency.

Table 51 shows that at a C/N<sub>0</sub> degradation of 1 dB, an additional e.g. 0.5 dB increases the margin of interference power by 2 dB.

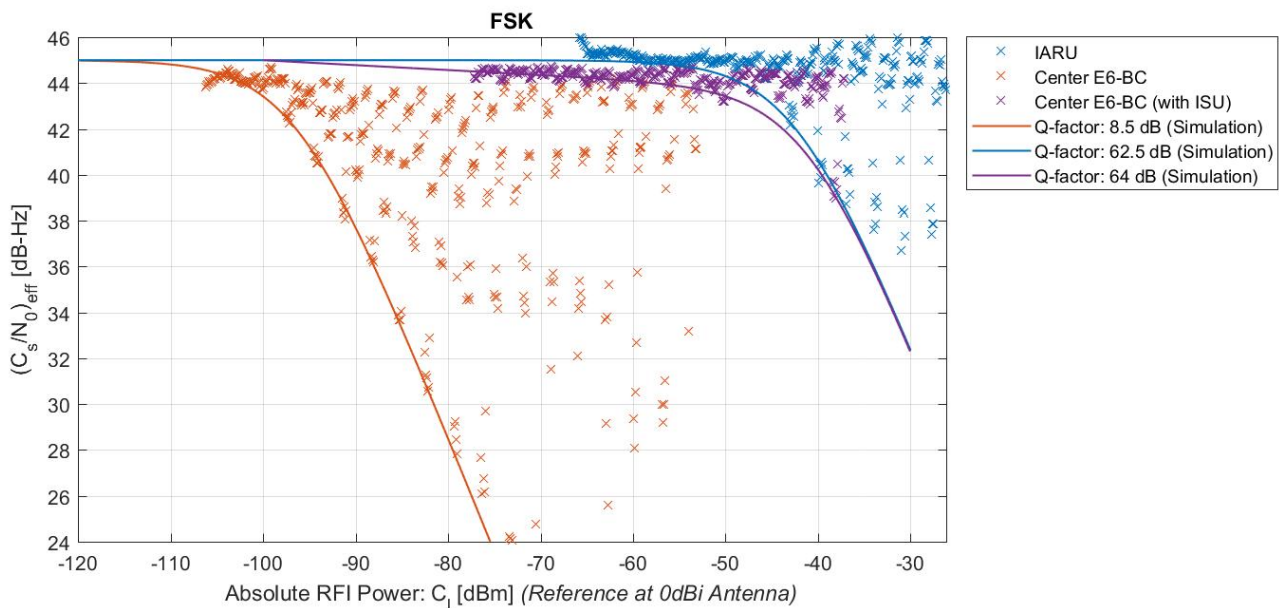

**Figure 21: Result summary for FSK signal**



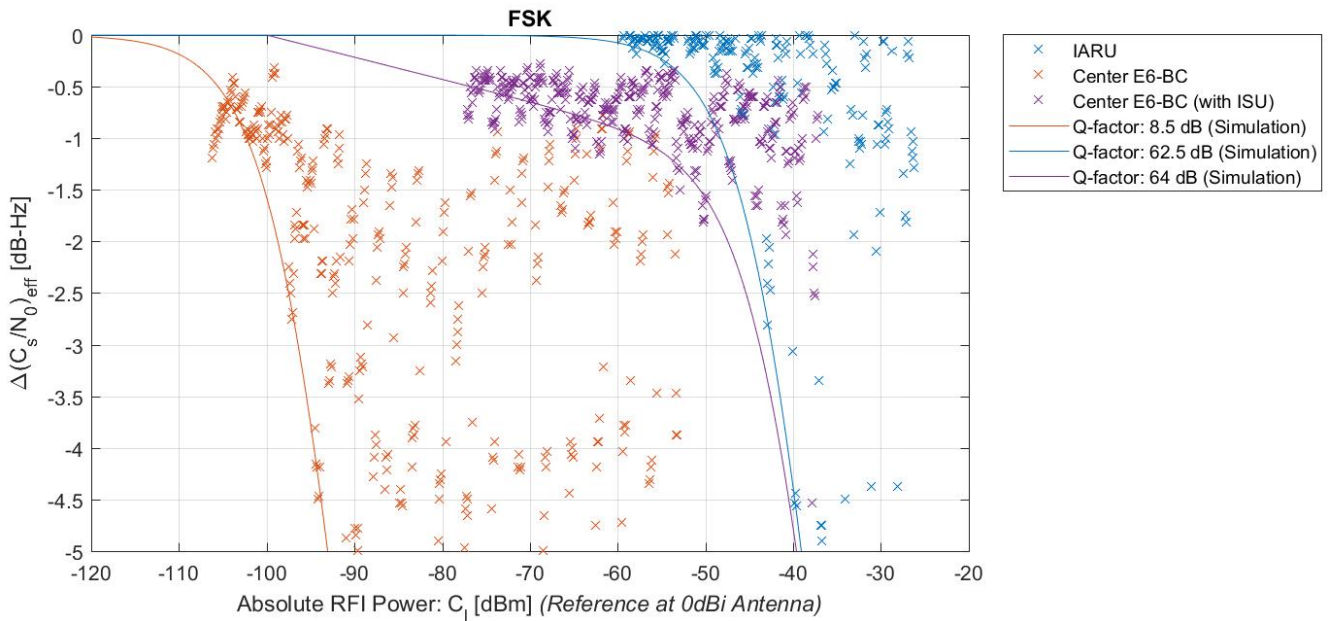

**Figure 22: Result summary showing C/N<sub>0</sub> changes relative to 45 dB/Hz for FSK signal**

**Table 51: Key values for FSK signal: maximum signal power at 0 dBi antenna to certain C/N<sub>0</sub> degradation allowance**

$\Delta C/N_0$	FSK 1299.21 MHz	FSK 1278.75 MHz	FSK 1278.75 MHz with ISU
-1 dB	-48.3 dBm	-102.3 dBm	-57.7 dBm
-1.5 dB	-46.3 dBm	-100.3 dBm	-50.7 dBm
-5 dB	-39.1 dBm	-93.1 dBm	-39.7 dBm
Q-factor	62.5 dB	8.5 dB	64 dB

**A5.3.2.5 FM-ATV (Test Case G4-01)**

The result for the FM-ATV signal is shown in Figure 23. Figure 24 shows the changes in C/N<sub>0</sub> relative to a reference of 45 dB/Hz. The signal was offset by 1.25 MHz from the centre frequency. It can be seen that the modulation’s constant envelope prevents strong fluctuations in the C/N<sub>0</sub>-indication.

Table 52 shows that at a C/N<sub>0</sub> degradation of 1dB, an additional e.g. 0.5 dB increases the margin of interference power by 2 dB.

Further tests regarding frequency offsets were not performed: according to the IARU Band plan, this type of signal normally uses that frequency.

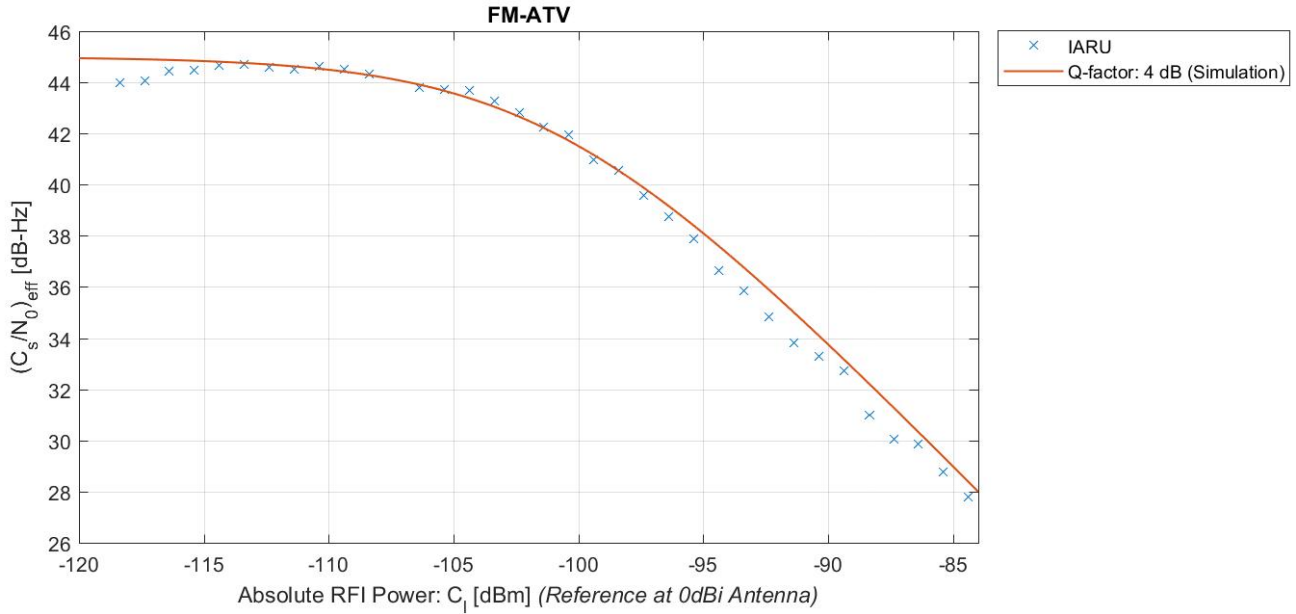

Figure 23: Result summary for FM-ATV

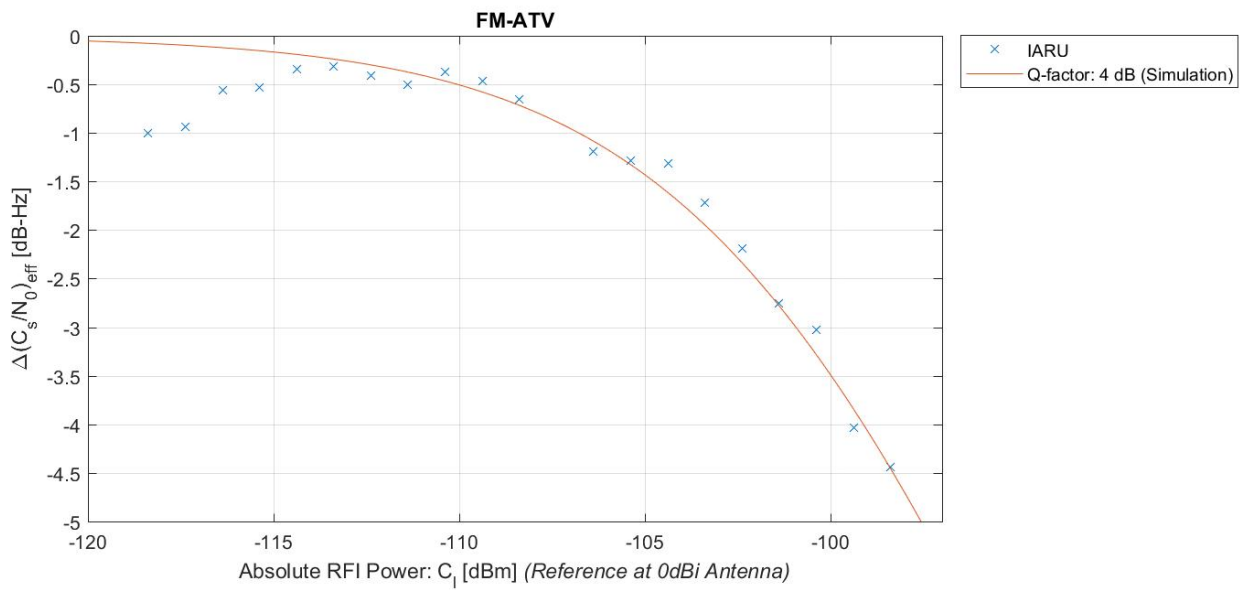

Figure 24: Result summary showing C/N0 changes relative to 45 dB/Hz for FM-ATV

Table 52: Key values for FM ATV signal: maximum signal power at 0 dBi antenna to certain C/N0 degradation allowance

$\Delta C/N_0$	FM ATV 1280.00 MHz	FM ATV 1278.75 MHz	FM ATV 1278.75 MHz with ISU
-1 dB	-106.8 dBm	N/A	N/A
-1.5 dB	-104.8 dBm	N/A	N/A
-5 dB	-97.6 dBm	N/A	N/A
Q-factor	4 dB	N/A	N/A

**A5.3.2.6 DVB-T ATV with 1MHz bandwidth (Test Cases G4-05, G4-06, G4-06x)**

The result for the DVB-T ATV-signal with a bandwidth of 1 MHz is shown in Figure 25. Figure 26 shows the changes in C/N<sub>0</sub> relative to a reference of 45 dBHz. In the offset case, the interfering signal's centre frequency was shifted 9.25 MHz away from E6 centre frequency. No strong fluctuations can be seen as compared to e.g. the Morse or FSK signal.

The result shows that a frequency offset relaxes the interference situation. Furthermore, the ISU performs differently as compared to the narrowband emissions, albeit for the power levels tested it still prevents the C/N<sub>0</sub> to degrade to less than 38 dBHz. This might be due to the following reasons:

- The current state of the ISU's development is to perform best on small band signals;
- The ISU removes those parts of the spectrum that have been identified as an unwanted signal. The wider the removed spectrum, the more power of the Galileo spectrum is also removed. Because of this removal, an inherent drop of C/N<sub>0</sub> by approx. 2 dB occurs. This can be seen at RFI level of approx. -71 dBm;
- The bump in the ISU-curve is due it's detection threshold: as long as the incoming signal is not rated as interference, the ISU does nothing at all.

Table 53 shows that at a C/N<sub>0</sub> degradation of 1 dB, an additional e.g. 0.5 dB increases the margin of interference power by 2 dB.

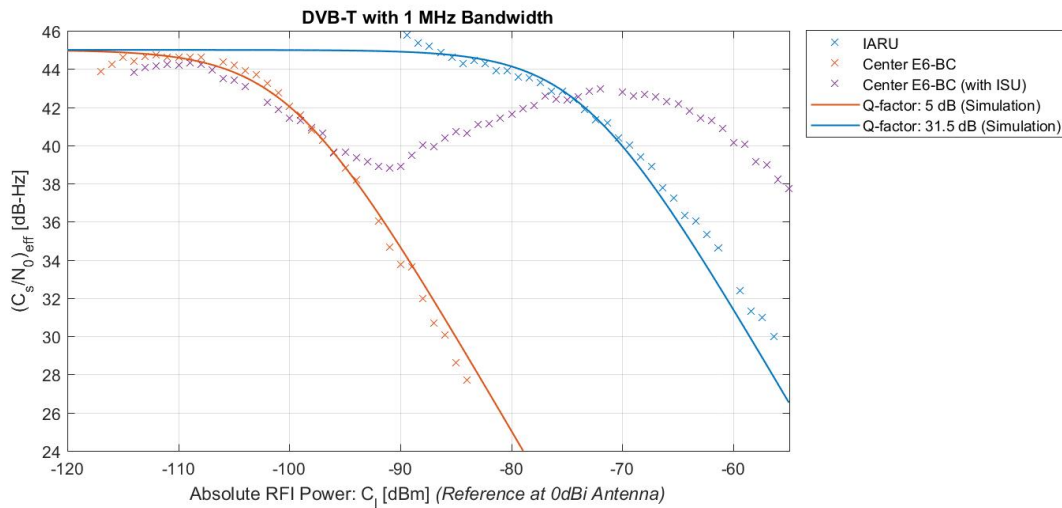

**Figure 25: Result summary for DVB-T ATV, 1 MHz bandwidth**

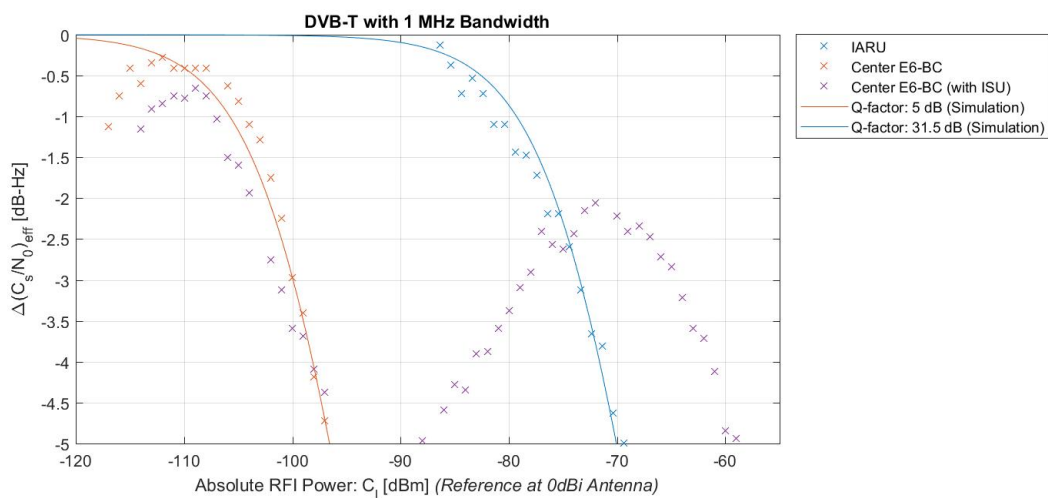

**Figure 26: Result summary showing C/N<sub>0</sub> changes relative to 45 dB/Hz for DVB-T ATV, 1 MHz bandwidth**

**Table 53: Key values for DVB-T ATV signal (1 MHz bandwidth): maximum signal power at 0 dBi antenna to certain C/N<sub>0</sub> degradation allowance**

$\Delta C/N_0$	DVB-T ATV 1 MHz 1280.00 MHz	DVB-T ATV 1 MHz 1278.75 MHz	DVB-T ATV, 1 MHz, 1278.75 MHz with ISU
-1 dB	-79.3 dBm	-105.8 dBm	-
-1.5 dB	-77.3 dBm	-103.8 dBm	-
-5 dB	-70.1 dBm	-96.6 dBm	-
Q-factor	-31.5 dB	5 dB	-

**A5.3.2.7 DVB-T ATV with 1MHz bandwidth, variable centre frequency offsets (Test Case G4-18)**

In addition, further tests were performed to study the influence of various carrier frequencies for the DVB-T signal. For that, the DVB-T signal level was kept constant, while the frequency was shifted through a portion of Galileo’s signal spectrum. The result is shown in Figure 27 with absolute C/N<sub>0</sub> values on the left Figure and C/N<sub>0</sub>-values relative to the value at  $\Delta f=15$  MHz (in the right Figure).

The figure can be read as follows: the Galileo signal is the more affected the closer the interferer is to its centre frequency. This complies largely with results reported in the previous sections. The spectral zero at the offset -5 MHz is not as vulnerable as the centre frequency, but more sensitive than the zero at -15 MHz.

The test was not extended to the positive frequency offset range, since the spectra of the E6-B/C signals involved are symmetric around their centre frequency. This general finding is considered sufficient for an initial estimation of the RF compatibility situation.

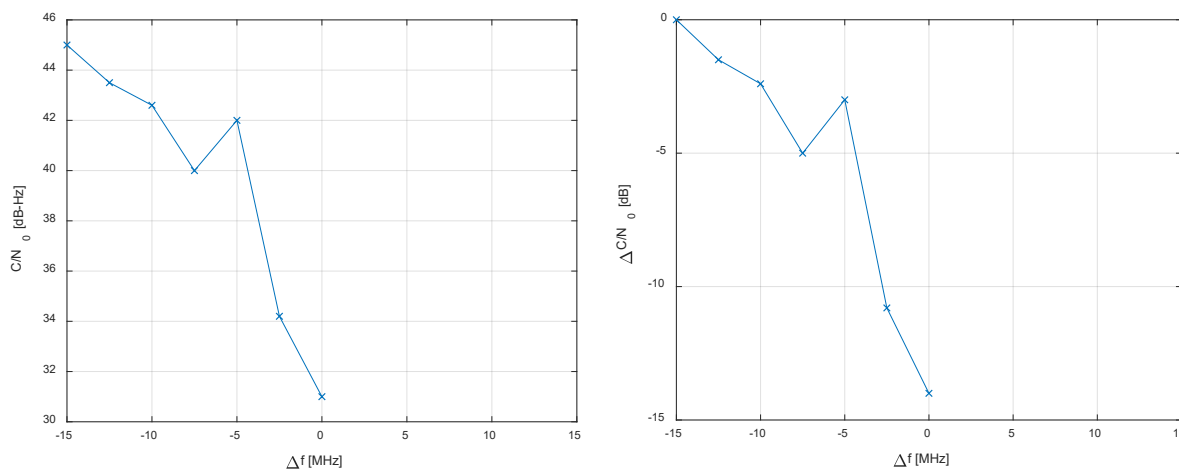

**Figure 27: Influence of different centre frequencies of the DVB-T signal. Left hand side: absolute C/N<sub>0</sub> values; right hand side: C/N<sub>0</sub>-values relative to the values at the frequency offset of -15 MHz**

**A5.3.2.8 DVB-T ATV with 4 MHz bandwidth (Test Cases G4-09, G4-10);  
DVB-S ATV with 6 MHz bandwidth (Test Case G4-14)**

The results for the DVB-T ATV-signal with a bandwidth of 4 MHz and the DVB-S signal (bandwidth: 6 MHz) are shown in Figure 28. Figure 29 shows the changes in C/N<sub>0</sub> relative to a reference of 45 dB/Hz. In the offset case (DVB-T only), the RFI carrier frequency was shifted 7.25 MHz away from E6 centre frequency. No strong fluctuations can be seen as compared to e.g. the Morse or FSK signal. When comparing this Figure to the 1 MHz DVB-T case, one has to remember that the offset in this case is smaller (interferer is closer to the centre

frequency) and the signal is wider (interferer's power is spread wider across the spectrum, reaching even further to the centre frequency). Apart from that, the DVB-S signal has a constant envelope, in contrast to the DVB-T OFDM signal.

The result shows that a frequency offset relaxes the interference situation, but far less than in the 1 MHz bandwidth case.

Table 54 shows that at a C/N<sub>0</sub> degradation of 1 dB, an additional e.g. 0.5 dB increases the margin of interference power by 2 dB.

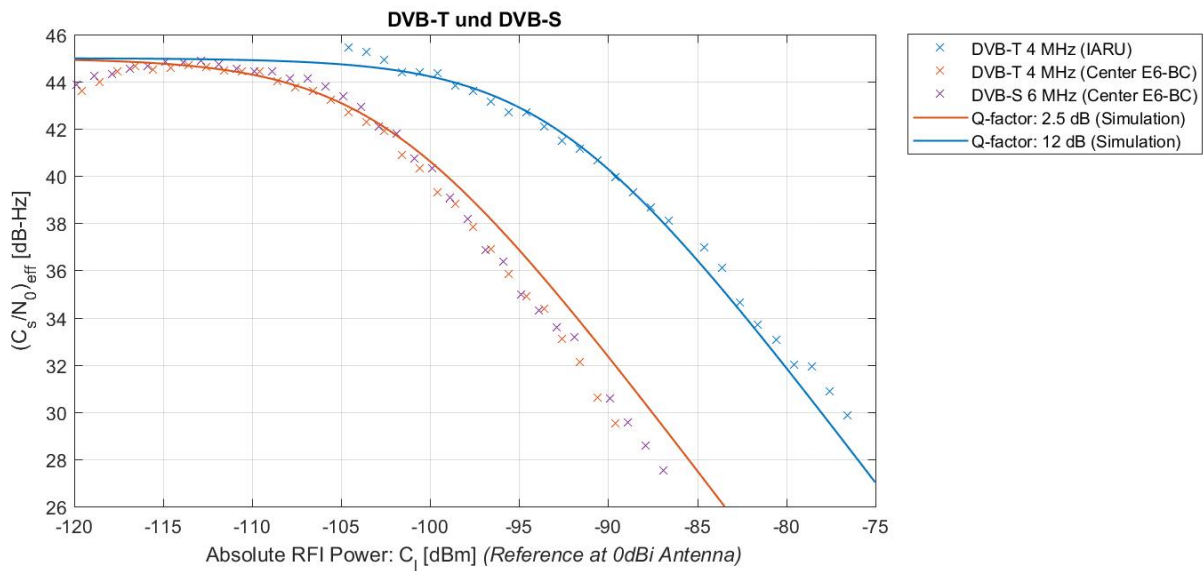

**Figure 28: Result summary for DVB-T ATV, 4 MHz bandwidth and DVB-S ATV, 6 MHz bandwidth**

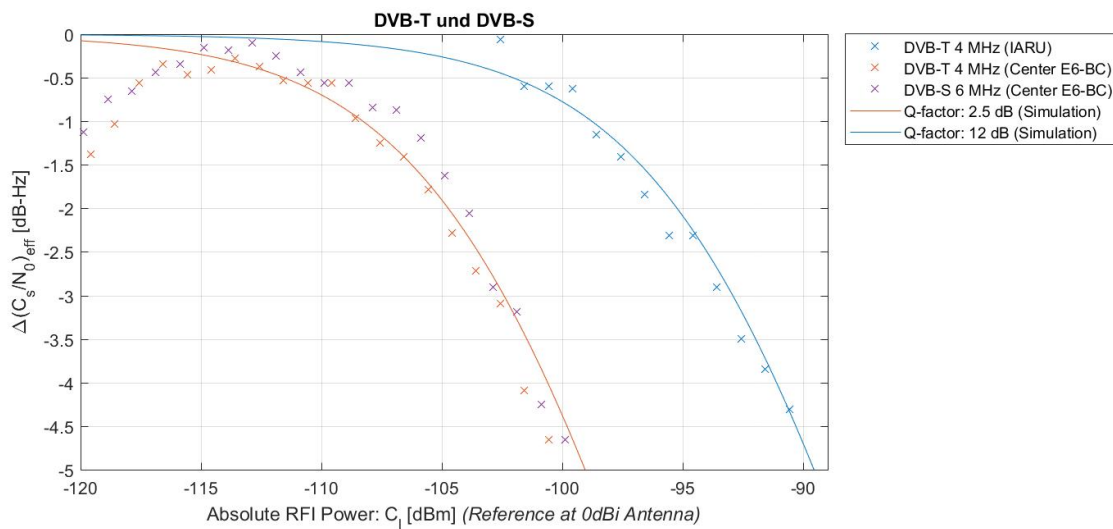

**Figure 29: Result summary showing C/N<sub>0</sub> changes relative to 45 dB/Hz for DVB-T ATV, 4 MHz bandwidth and DVB-S ATV, 6 MHz bandwidth**

**Table 54: Key values for DVB-T ATV signal (4 MHz Bandwidth) and DVB-S (6 MHz Bandwidth): maximum signal power at 0 dBi antenna to certain C/N<sub>0</sub> degradation allowance**

$\Delta C/N_0$	DVB-T ATV 4 MHz 1286.00 MHz	DVB-T ATV 4 MHz, and DVB-S 6 MHz 1278.75 MHz	DVB-T ATV, 4 MHz, and DVB-S 6 MHz 1278.75 MHz with ISU
-1 dB	-98.8 dBm	-108.3 dBm	N/A
-1.5 dB	-96.8 dBm	-106.3 dBm	N/A
-5 dB	-89.6 dBm	-99.1 dBm	N/A
Q-factor	12 dB	2.5 dB	N/A

**A5.3.2.9 Test for independence of initial C/N<sub>0</sub> (Group G4-20)**

To study if the initial set C/N<sub>0</sub>-ratio has an influence on the measurement result, the following test was performed: the level of the simulated Galileo signals was set in such a way that every two satellite signals had the same power. The noise power level remained unchanged with respect to the previous measurements. Then, the DVB-T signal with 1 MHz bandwidth was applied as RFI on the E6 centre frequency. The test sequence started again (setting a trigger point, returning to the initial signal power level and gradually increasing the RFI power). The result is shown in Figure 30.

It can be seen that all lines run in parallel to each other. This means that the absolute value of the initial C/N<sub>0</sub> has no influence on C/N<sub>0</sub> degradation as long as that C/N<sub>0</sub> is far above the receiver's sensitivity to capture the wanted signal.

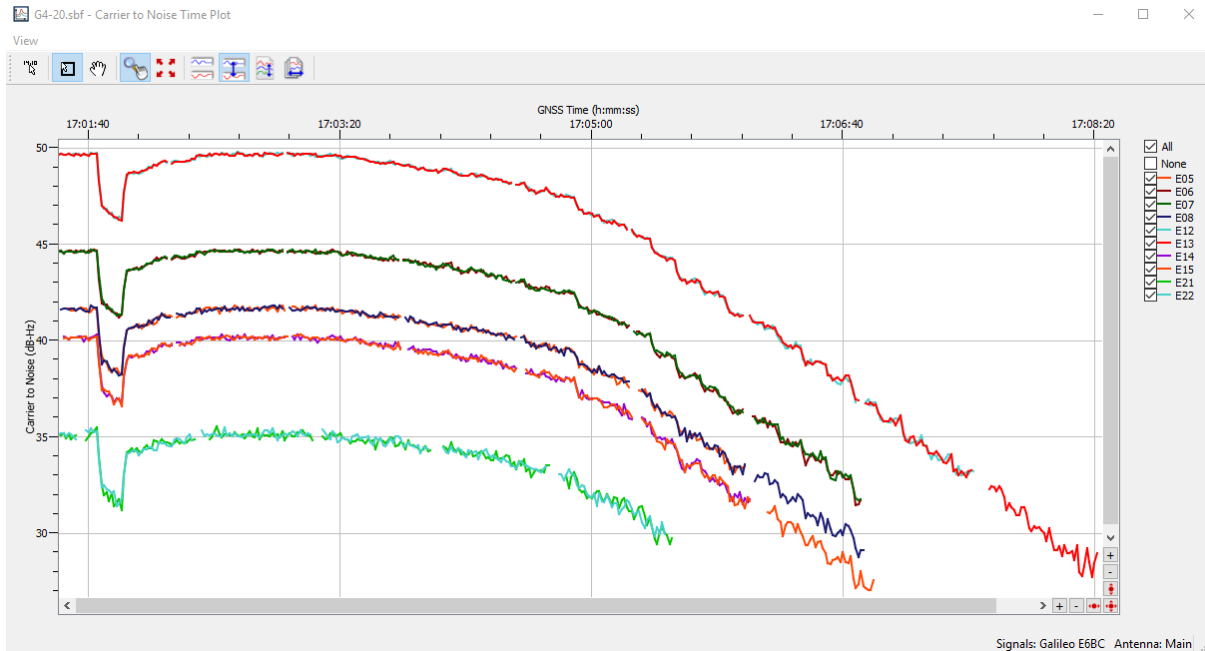

**Figure 30: C/N<sub>0</sub> vs. time with different Galileo signal power levels, interfered by a DVB-T signal (1 MHz bandwidth, E6 centre frequency)**

### A5.3.3 Summary

Measurements were performed to study the effects on the post-correlation C/N<sub>0</sub> when different amateur radio signals arrive at a 0 dBi antenna of a GalileoE6-B/C DS SS CDMA receiver. Many different signal types and frequency combinations were investigated to cover not only worst case, but also typical situations.

The tests performed considered all signals that are usually emitted in the amateur service on frequencies in accordance with the IARU band plan as well as on the E6 centre frequency.

The findings can be summarised as follows:

- The worst case occurs when an interfering signal is applied on the E6 centre frequency;
- Vice versa: frequency separation from centre frequency yields significantly higher tolerable levels for the interfering signal (e.g. when using frequencies the IARU Band plan);
- A non-constant envelope of the interfering signal leads to high scattering of the receivers observed C/N<sub>0</sub>;
- Although DVB-T OFDM-signals also employ a non-constant envelope, they are fast enough to avoid such fluctuations and have apparently less dynamic amplitude changes than, for example, an on/off-keyed narrowband signal such as used in Morse telegraphy;
- The used Interference Suppression Unit (ISU) can significantly reduce the impact of interfering signals, particularly for narrowband signals (B < 150 kHz);
- Even if the ISU's performance was not tested against the Morse signal, one can expect a similar behaviour as seen in the e.g. SSB signal case;
- Against the wider amateur TV signals, the used ISU did not lead to a strong receiver immunity;
- The wider the signal to be suppressed (i.e. filtered), the more energy is taken from the E6 signal. This reduction of the RF signal's C/N<sub>0</sub> leads to a worse C/N<sub>0</sub> at the receiver's output;
- It is to be noted that the used receiver's input filter is smaller than specified in [1] (30 MHz instead of 40.92 MHz). Nonetheless, the RF level measurements respect the full channel bandwidth.

## A5.4 GALILEO E6-B PROBABILITY OF BIT ERROR CONDITIONS UNDER VARYING C/N<sub>0</sub>

### A5.4.1 Relation between Eb/No and C/N<sub>0</sub>

In the Galileo system, the following relation holds between the carrier to noise and energy per bit to noise ratios:

$$\left(\frac{C}{N_0}\right)_{dB} = \left(\frac{E_b}{N_0}\right)_{dB} + 10\lg(R_d \cdot r \cdot D)$$

where the symbol transmission rate is given by  $R_d$ , the channel code rate  $r$  and the power distribution between the data and pilot channel  $D$ .

The E6-B signal has a gross bit rate of 1000 symbols per second with one symbol representing one bit. The error correction scheme is three-fold: a cyclic redundancy check (CRC), a half-rate convolutional forward error correction (FEC) and block interleaving. The net bit rate is approx. 500 bps. The power distribution in the RF channel is equal between the pilot and data channel. This leads to:

$$\left(\frac{C}{N_0}\right)_{dBHz} = \left(\frac{E_b}{N_0}\right)_{dBHz} + 10\lg\left(1000 \cdot 0.5 \cdot \left(\frac{1}{2}\right)^{-1}\right)$$

$$\left(\frac{C}{N_0}\right)_{dBHz} = \left(\frac{E_b}{N_0}\right)_{dBHz} + 30 \text{ dB}$$

### A5.4.2 BER for E6B-C

In an AWGN channel with an assumed coherent receiver (perfect tracking performance in terms of time and frequency), the BER is given by:

$$P_b = \frac{1}{2} \operatorname{erfc}\left(\frac{E_b}{N_0}\right)$$

Using Matlab's® BER-Tool, Figure 31 and Figure 32 can be derived for the uncoded and coded (hard- and soft decision decoder) case. The simulations are verified by measurements on two receivers [16].

In the following, a hard decision decoder is assumed.

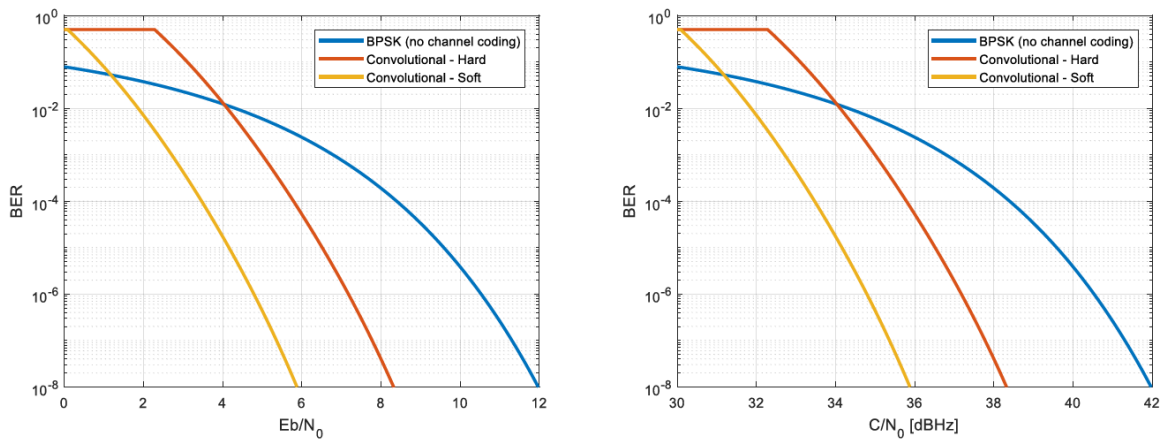

**Figure 31: BER for Galileo E6-B/C with no channel coding and convolutional decoding with hard and soft decision in AWGN channel, no implementation losses assumed**

### A5.4.3 Relation between minimum power level of Galileo E6-B/C and C/N0

[1] states that the Galileo satellites provide the minimum signal level of -125 dBm for user elevation angles above 5 degrees (nadir) at the output of an ideally matched (RHCP) 0 dBi antenna.

The gain pattern of an antenna is a function of azimuth and elevation. For GNSS receive antennas, the azimuth pattern is typically uniform and can be neglected.

The gain pattern for the elevation is dependent on the model. In the following, two different elevation patterns of (geodetic) antennas are sketched.

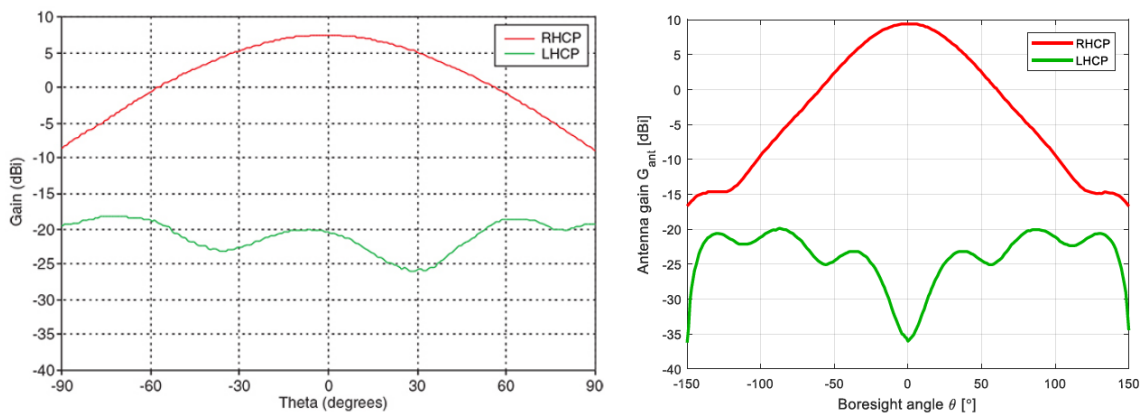

**Figure 32: Example of elevation gain patterns of two different geodetic antennas [17], [18]**



Patterns related to more consumer-oriented products -- focussed on the performance of GPS on L1 -- can be taken from [19]. For the two antennas shown, one can see that the 0 dBi-line is reached at a boresight angle of approx. 60°. At 5° above nadir, both antennas are at about -8 dBi.

The noise figure of GNSS receivers is typically dominated by the noise of the active antennas. A typical value of the antenna noise figure F is 2 dB [20].

In total, the expectable Carrier-to-Noise level for a satellite 5° above nadir is given by:

$$\left(\frac{C}{N_0}\right)_{min,dBHz} = P_{min,dBm} - g_{Ant} - (N_0,dBm/Hz + F_{dB})$$

$$\left(\frac{C}{N_0}\right)_{min,dBHz} = -125 \text{ dBm} - 8 \text{ dBi} - \left(-174 \frac{\text{dBm}}{\text{Hz}} + 2 \text{ dB}\right) = 39 \text{ dBHz}$$

## A5.5 QUANTIFICATION OF INTERFERENCE AND OPTIONS FOR RFI MITIGATION

### A5.5.1 Protection criteria determined by C/N<sub>0</sub> degradation down to a certain BER

The difference between the reception at the minimum signal level and a target BER is the degradation allowance due to any kind of RFI or signal propagation related phenomena. If one assumes the minimum CN<sub>0</sub> of 39 dBHz as stated in section A6.4.3 and allows a minimum BER of 1e<sup>-2</sup> (coupled to an C/N<sub>0</sub> of 34 dBHz, c.f. section A6.4.3), then a margin of 5 dB is allowed.

## ANNEX 6: MEASUREMENTS FROM EC JRC ON INTERFERENCE EVENT FROM AAMATEUR STATIONS TO GNSS IN ITALY

Evidence of interference events from amateur stations to Galileo receivers are provided in this annex referring to multiple events observed in May/June 2021 in the region of Varese (Italy), and assessed by the Joint Research Centre (JRC) of the European Commission (EC). Following the events reported below and using them as a reference, further measurements were conducted within the JRC laboratories in the effort to characterize the effect of different AS emission types (at various carrier frequencies and power levels) on multiple GNSS receivers.

In June 2021 the Joint Research Centre of the European Commission executed a number of data collections within its premises (located in Ispra, in the vicinity of Varese, Italy). Those data collections dealt with the testing of Galileo High Accuracy Service (HAS)<sup>12</sup>, currently in a pre-operational testing phase of its Signal in Space (SiS)<sup>13</sup>, transmitted in the E6 band (1258-1300 MHz). In the context of the testing preparation, JRC scientists are performing a number of data collections under diverse reception conditions, including static open sky and mobile sub-urban reception. The scope is to test a bench of Galileo E6 receivers in order to confirm adequate processing of the E6-BC signals (acquisition, tracking) as well as adequate demodulation of HAS data (carried by the E6-B signal component). A bench of several receivers enabled to process E6-BC signals from different manufacturers and targeting different market segments is being setup within the JRC Testing and Demonstration Hub for the EU GNSS Programmes<sup>14</sup>.

Analysing some of the data collected (consisting of recorded IF samples from all Galileo satellites in view over E1 and E6 bands), a strong narrowband emission within the E6 band has been identified. The concerned emission is a narrowband signal observed at a frequency of 1297.3 MHz. A screenshot of the emission as visualized on a spectrum analyser is provided in Figure 33.

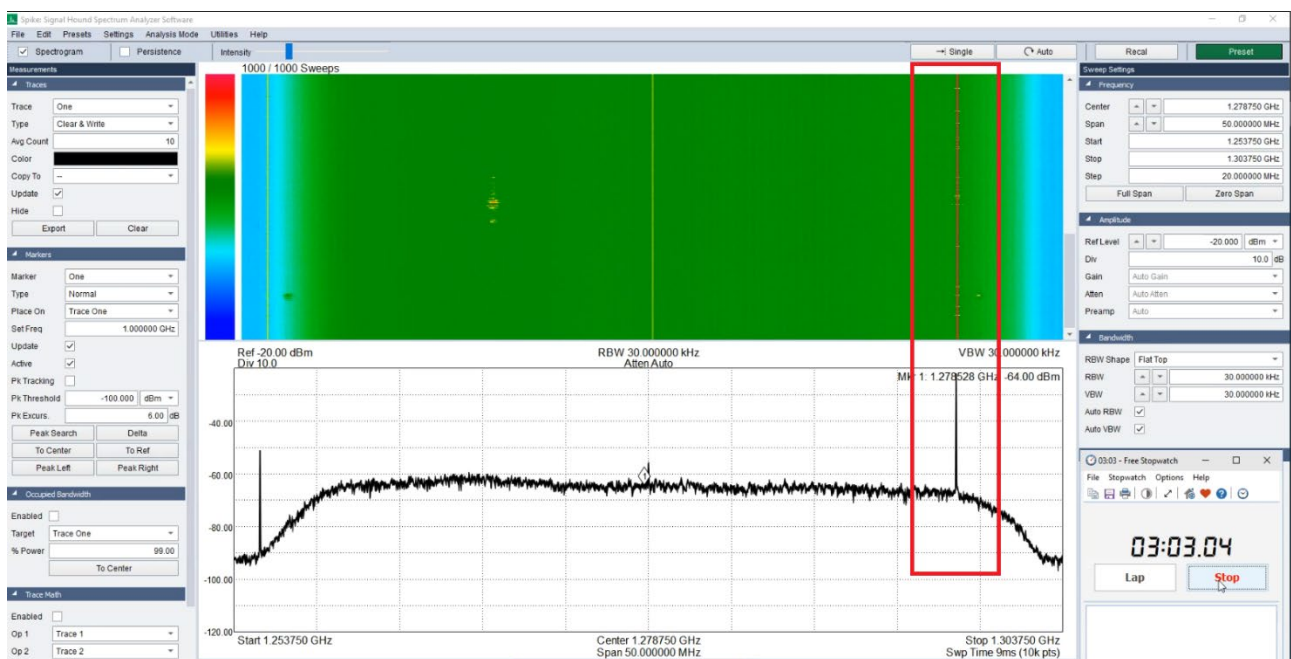

**Figure 33: Spectrum Analyser displaying interfering narrowband signal at 1297.3 MHz**

Note that the emission is characterised by a strong power, being more than 40 dB above the noise floor.

The emission has been analysed and it was identified to be an FM modulated signal transmitted by an Amateur Radio Repeater. The repeater was identified through the Ministerial identifier transmitted through the signal,

<sup>12</sup> [https://www.gsc-europa.eu/sites/default/files/sites/all/files/Galileo\\_HAS\\_Info\\_Note.pdf](https://www.gsc-europa.eu/sites/default/files/sites/all/files/Galileo_HAS_Info_Note.pdf)

<sup>13</sup> <https://www.euspa.europa.eu/newsroom/news/euspa-launches-high-accuracy-service-call>

<sup>14</sup> JRC125180, JRC Testing and Demonstration Hub for the EU GNSS Programmes, 2021, ISBN 978-92-76-39185-2

which included also a code specifying its position (Maidenhead locator system). Recordings of the audio messages and identifiers of the Radio Repeater can be made available in the case of need.

The emission was observed to last about 15 seconds, and repeating regularly every 2/3 minutes. This behaviour seems compatible with the repeater transmitting its Ministerial identifier in the absence of an input signal making use of the channel.

Following this observation, an analysis has been performed to check the possible presence of this emission in other times beyond the one of the data collection (June 14th, 15:30-16:00 UTC). JRC has a permanent spectrum monitoring station deployed on its premises and logging spectrum measurements 24/7. Reviewing some of those data, some interesting cases were identified. It is important to specify that the analysis, looking only at data collected in May/June 2021, did not pretend to be exhaustive and was not looking to all data available but just focusing to identify some more relevant events. Other events might have happened that are not reported here.

In the following figures spectrograms from the JRC Spectrum Monitoring station are provided for some relevant cases that were identified. Some of the identified events are of the same kind as the one previously discussed, and therefore characterised by short emissions (some seconds) repeated over time, compatible with the repeater transmitting its identifier. Those are reported in Figure 34, Figure 35 Figure 36, Figure 37, Figure 38 and Figure 39.

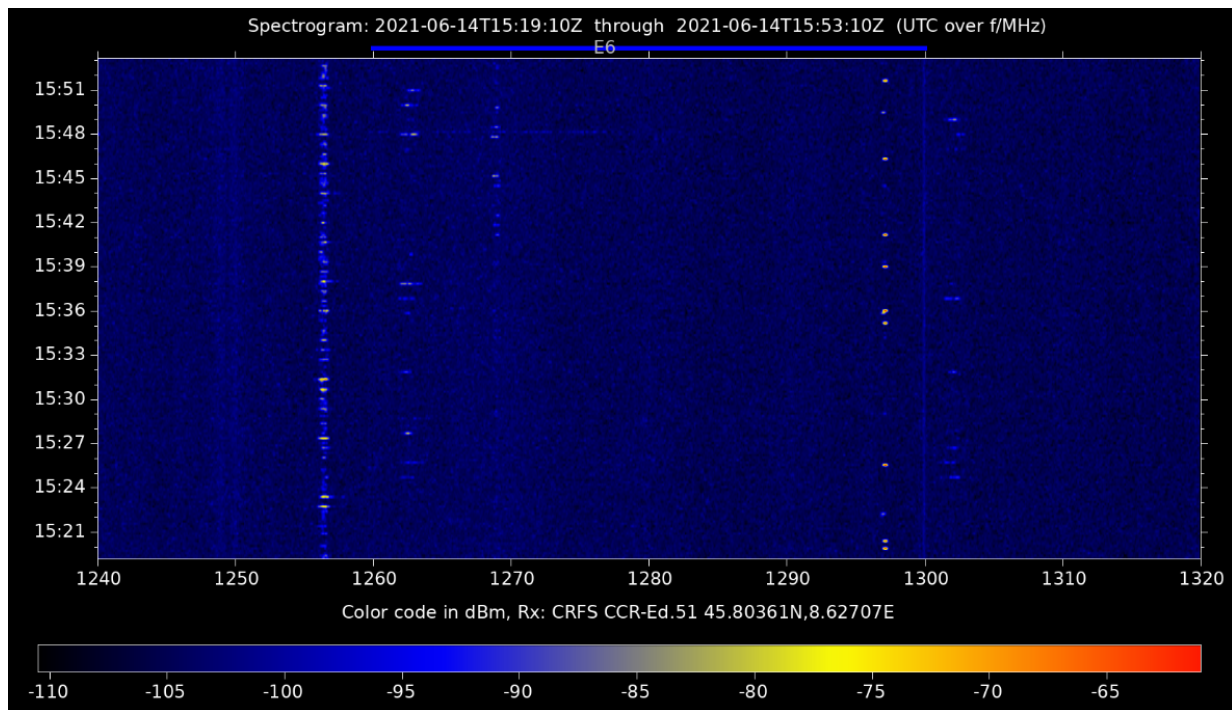

**Figure 34: Spectrogram 1240-1300 MHz – 14 June 2021, 15:19-15:53 UTC (Case 1)**

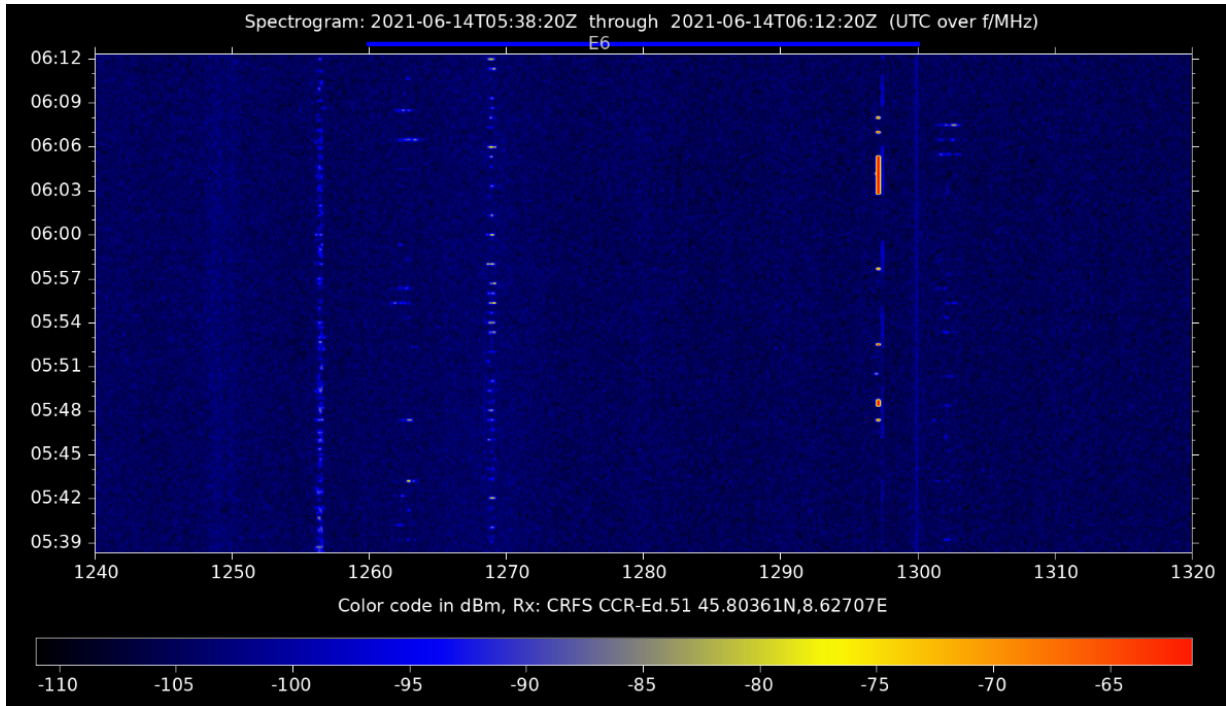

Figure 35: Spectrogram 1240-1300 MHz – 14 June 2021, 5:38-6:12 UTC (Case 2)

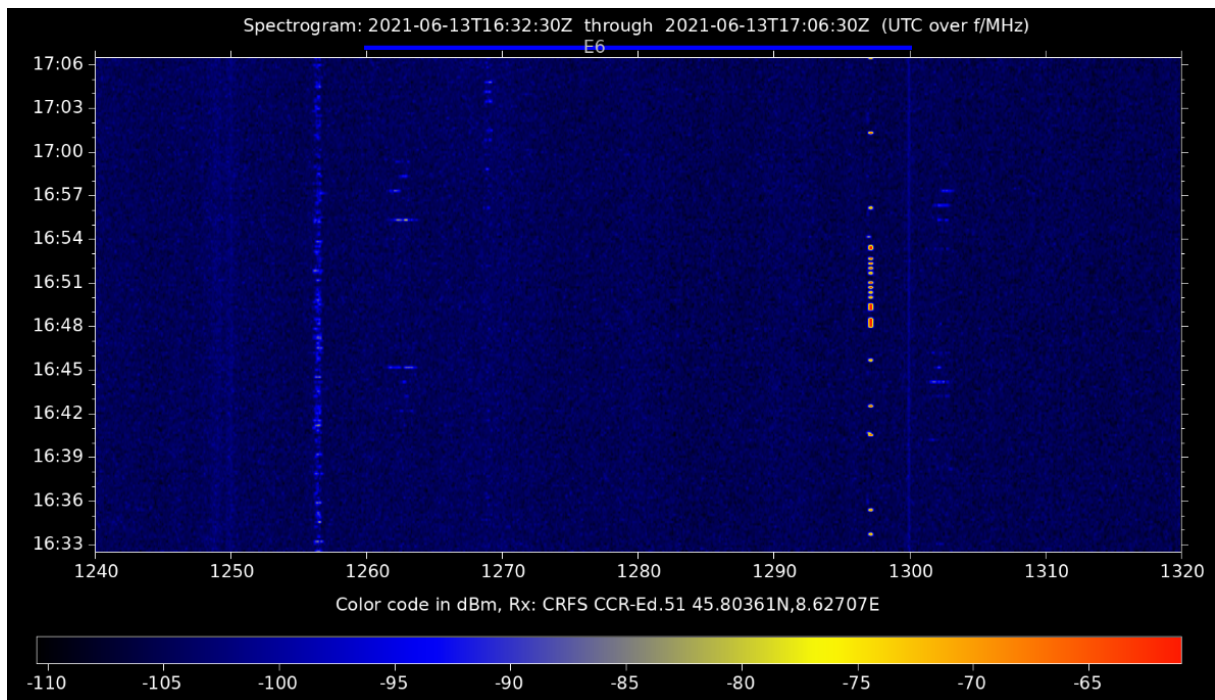

Figure 36: Spectrogram 1240-1300 MHz – 13 June 2021, 16:32-17:06 UTC (Case 3)

Other cases have been observed during which instead the emission is continuous over several minutes, possibly corresponding to an effective transmission of a message through the repeater (Figure 37, Figure 38 and Figure 39,). In these cases, it is interesting to observe the presence of a second emission at 1291 MHz, received with a lower power, and compatible with a possible uplink to the repeater.

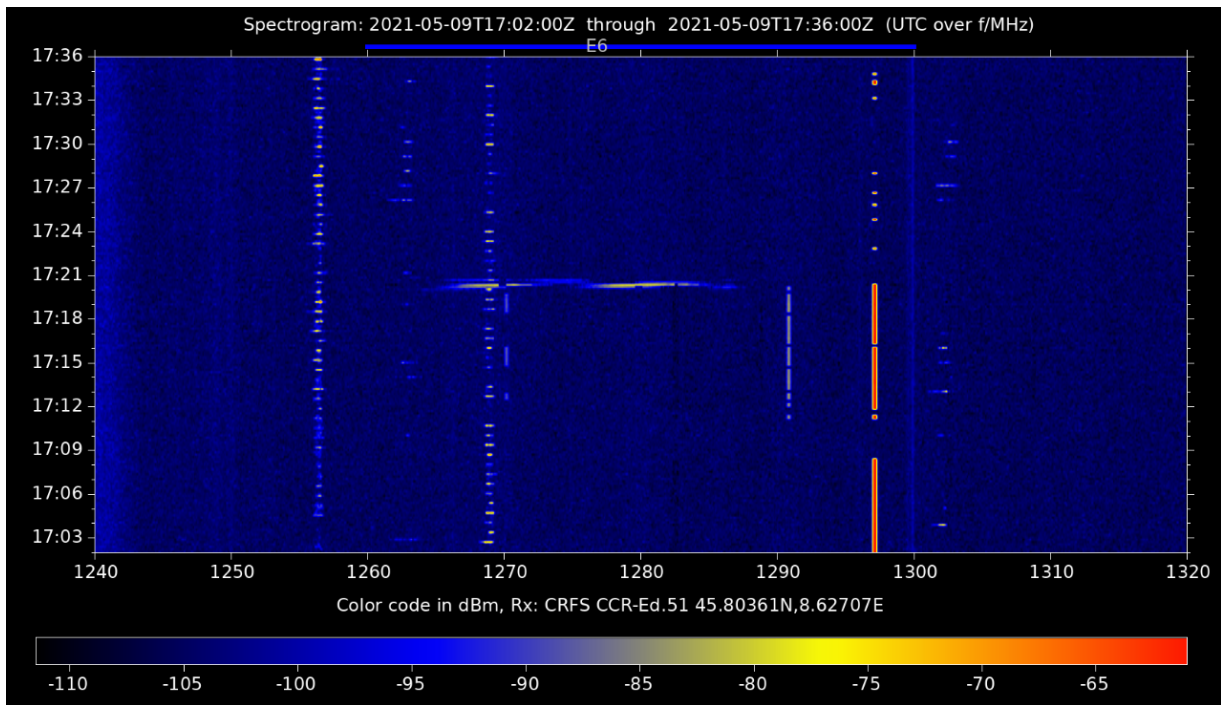

Figure 37: Spectrogram 1240-1300 MHz – 14 June 2021, 17:02-17:36 UTC (Case 4)

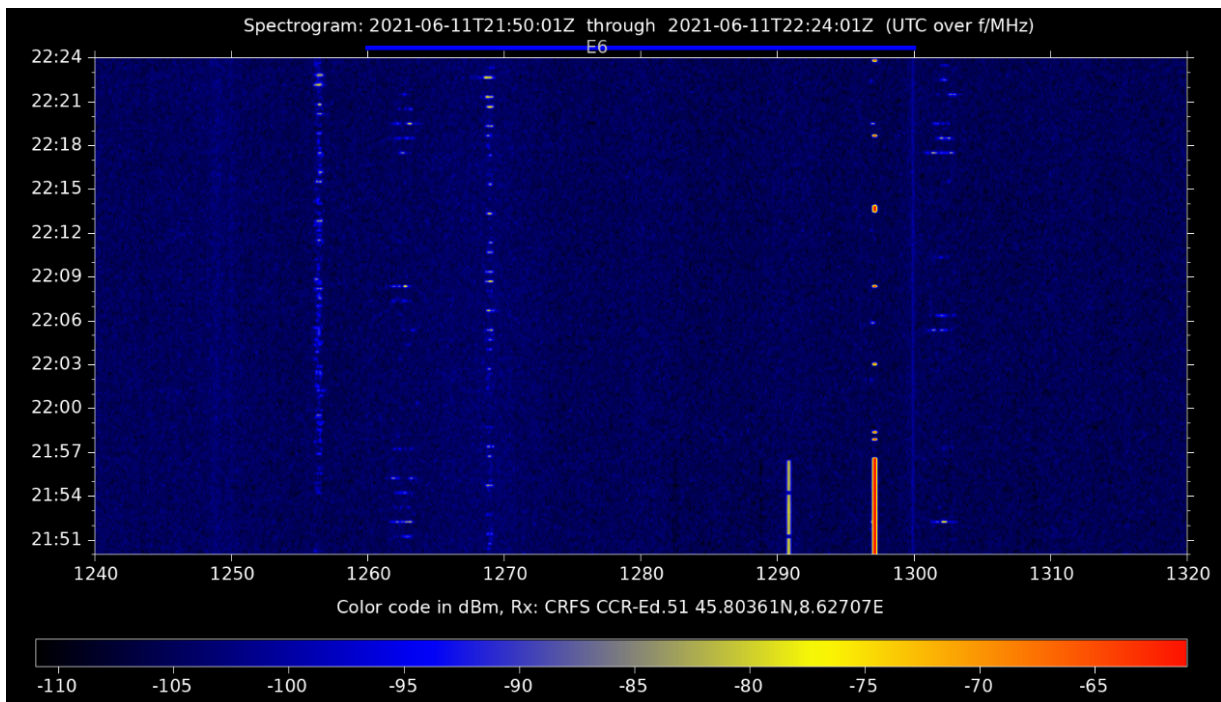
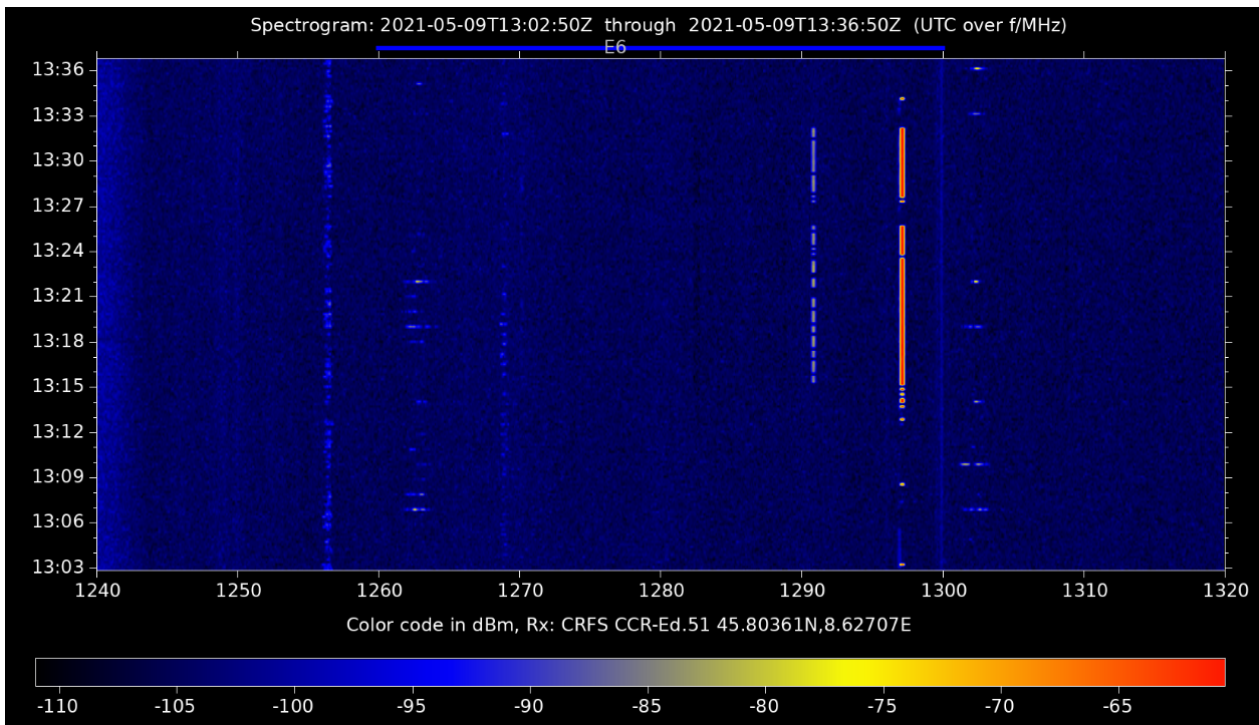

Figure 38: Spectrogram 1240-1300 MHz – 11 June 2021, 21:50-22:24 UTC (Case 5)



**Figure 39: Spectrogram 1240-1300 MHz – 9 May 2021, 13:02-13:36 UTC (Case 6)**

In all the figures above, it is interesting to observe the contemporary presence of emissions from radars, whose typical spectral patterns (pulsed signals) are well visible between 1255 and 1270 MHz. There are two airports in the area (the International Airport of Malpensa and the Military Airport of Cameri), both about 25 km southern of Ispra. It is important to mention that those emissions are managed in most of the receivers through pulse blanking, as radars are co-primary in the band and must be tolerated to a certain extent. Thanks to this blanking mitigation techniques most of the interference effect is removed before the correlation. Still, the receiver performance is affected by this operation as, by definition, the blankers are causing also a loss of “useful power”. As such, the necessary coexistence with the co-primary service in the band is already “costing” to GNSS receivers a substantial loss and has to be accounted for within the system margins.

During the events reported above there were two E6 capable receivers logging 24/7 GNSS data. Logs from a third receiver are available for the event on June 14th. An analysis has been performed to observe the impact of the different events on the post-correlation C/N<sub>0</sub>. The results are provided in the following figures. For obvious reasons the receivers are anonymized and marked as “Receiver A”, “Receiver B” and “Receiver C”. It is important to mention that the three receivers are all high-end, multi-band, multi-GNSS receivers, very well-known and widely employed for professional applications in the high-accuracy domain worldwide.

For what matters the Case 1 (14 June 2021 15:19-15:53 UTC, Figure 34), during which the interference is present only in short intervals, logs from three receivers are available. The C/N<sub>0</sub> for an interval of 30 minutes are represented in the three figures next:

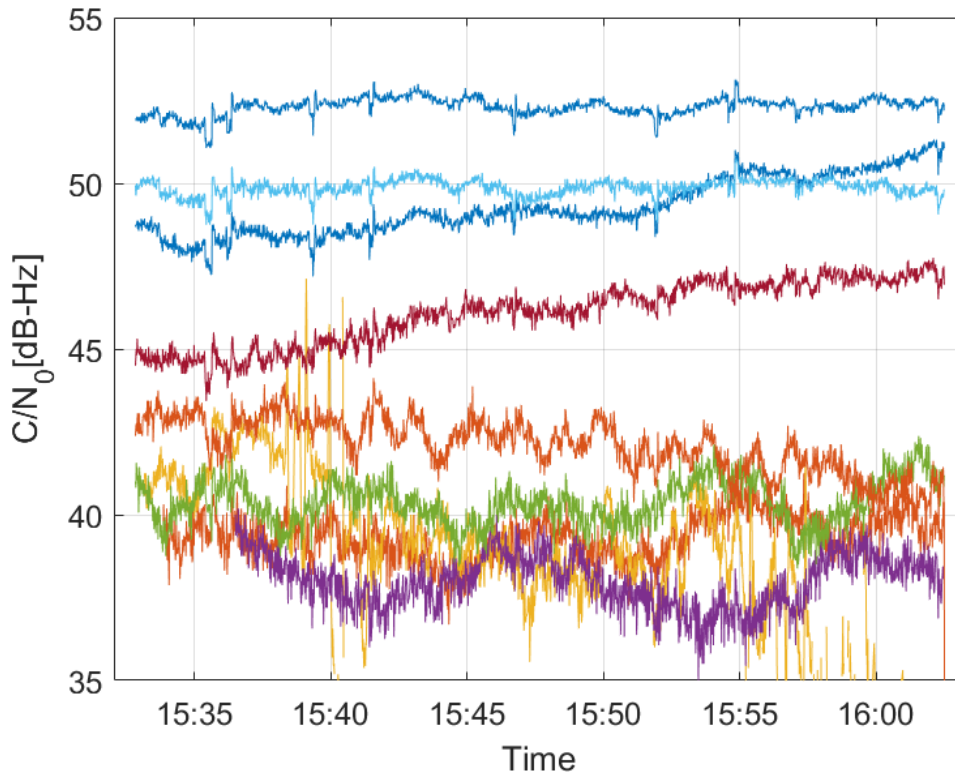

Figure 40: C/N<sub>0</sub>, Receiver A, E6-B signal, all satellites in view (Case 1)

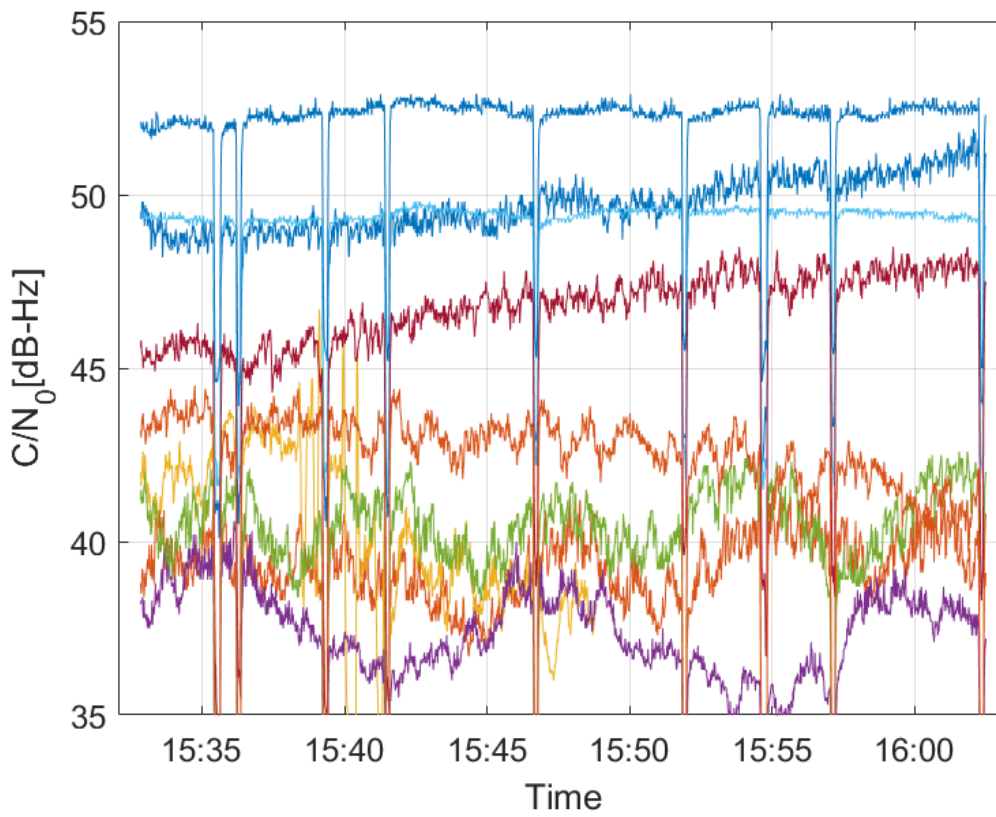
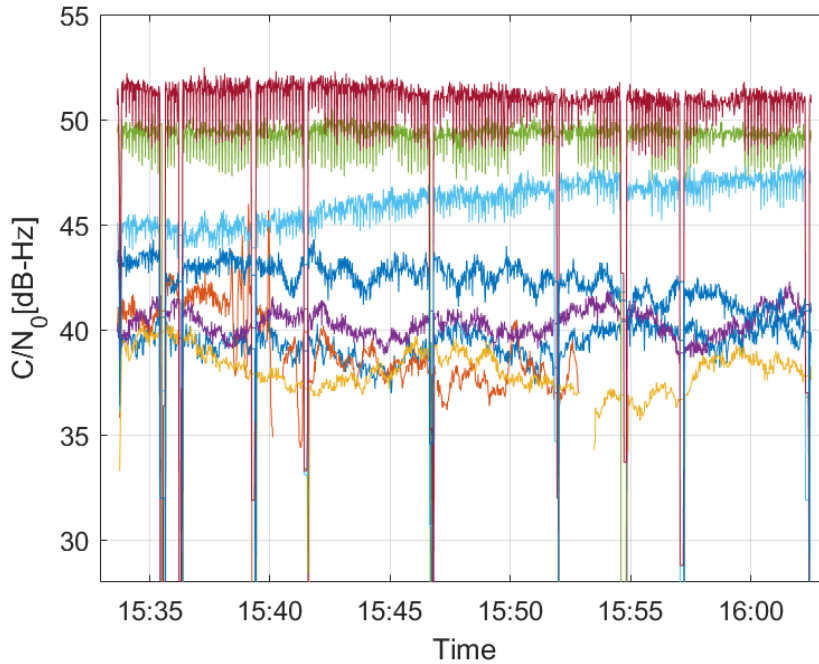

Figure 41: C/N<sub>0</sub>, Receiver B, E6-BC signal, all satellites in view (Case 1)



**Figure 42: C/N<sub>0</sub>, Receiver C, E6-BC signal, all satellites in view (Case 1)**

As it can be seen, even if the interfering signal is lasting few seconds (and repeating itself every few minutes), this is causing evident drops in the carrier to noise ratio estimated by the different receivers operating during the event. The receiver A has an instantaneous degradation of about 2 dB on all the satellites when the interfering signal is present, while the degradation on Receiver B and Receiver C is much more evident, in the order of about 10 dB and 20 dB respectively, again on all satellites in view.

In order to provide evidence that this effect is coming from the interference (beyond the perfect alignment of the distortions with the presence of the interfering signal), in the following figure the C/N<sub>0</sub> estimated by Receiver B while processing E1 signals (1575 MHz) is provided for comparison.

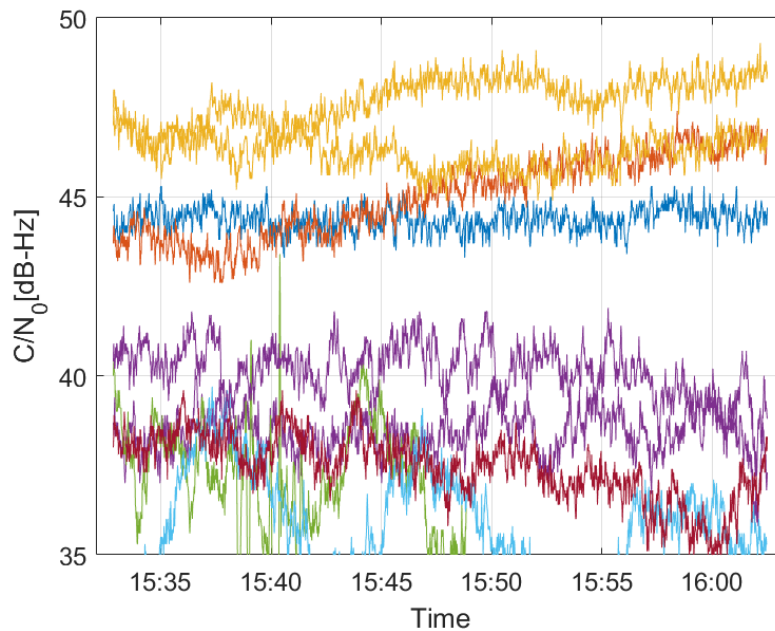
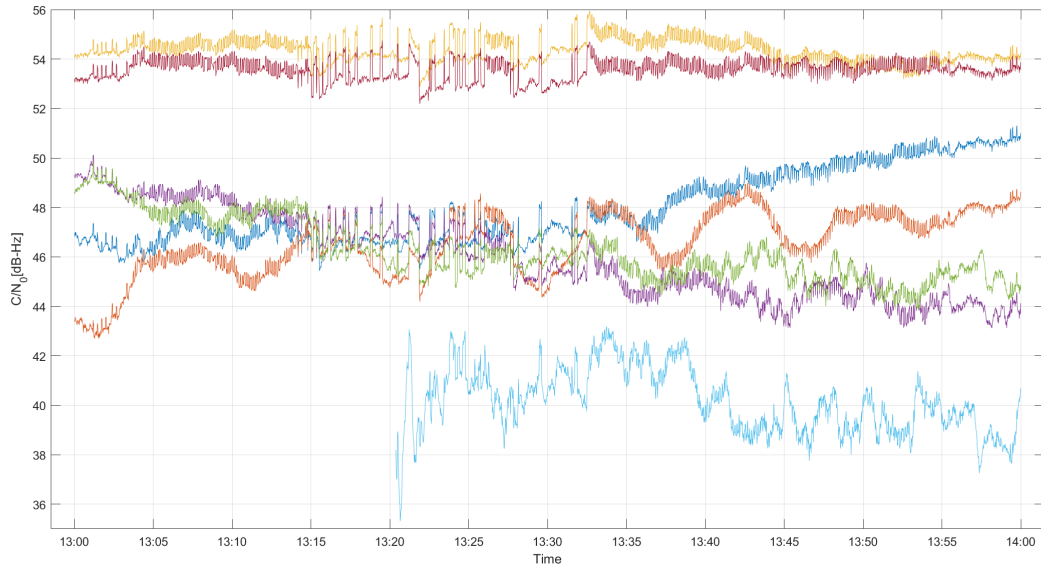

**Figure 43: C/N<sub>0</sub>, Receiver B, E1-BC signal, all satellites in view (Case 1)**



As it can be seen in Figure 43, the C/N<sub>0</sub> of the receiver while processing Galileo E1-BC signals is absolutely nominal.

Looking at the Case 6 (Figure 39), which is the one presenting the most extensive interfering event with more than 15 minutes of almost uninterrupted transmission from the repeater, the C/N<sub>0</sub> measured over one hour at the two receivers operating during the event is represented in the two figures next:



**Figure 44 C/N<sub>0</sub>, Receiver A, E6-B signal, all satellites in view (Case 6)**

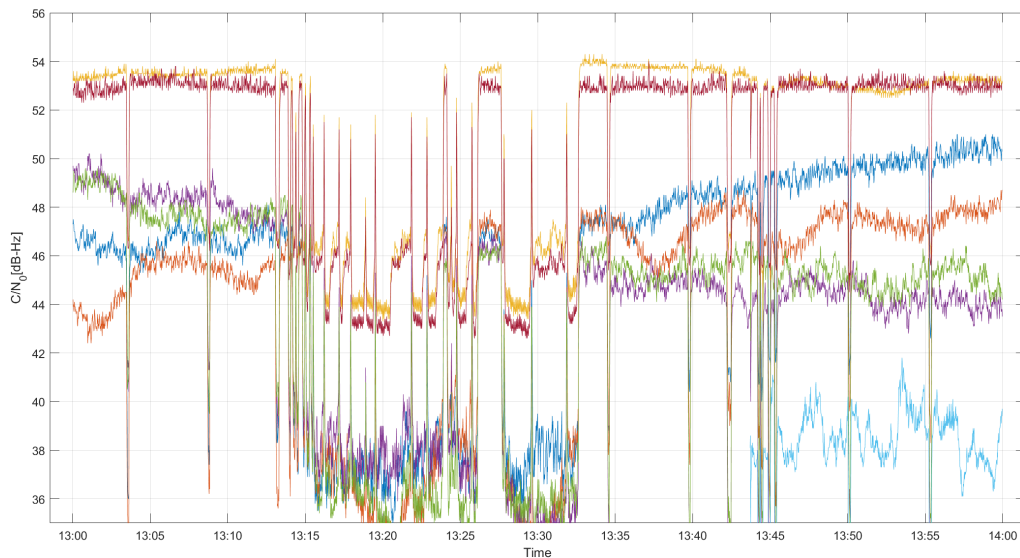
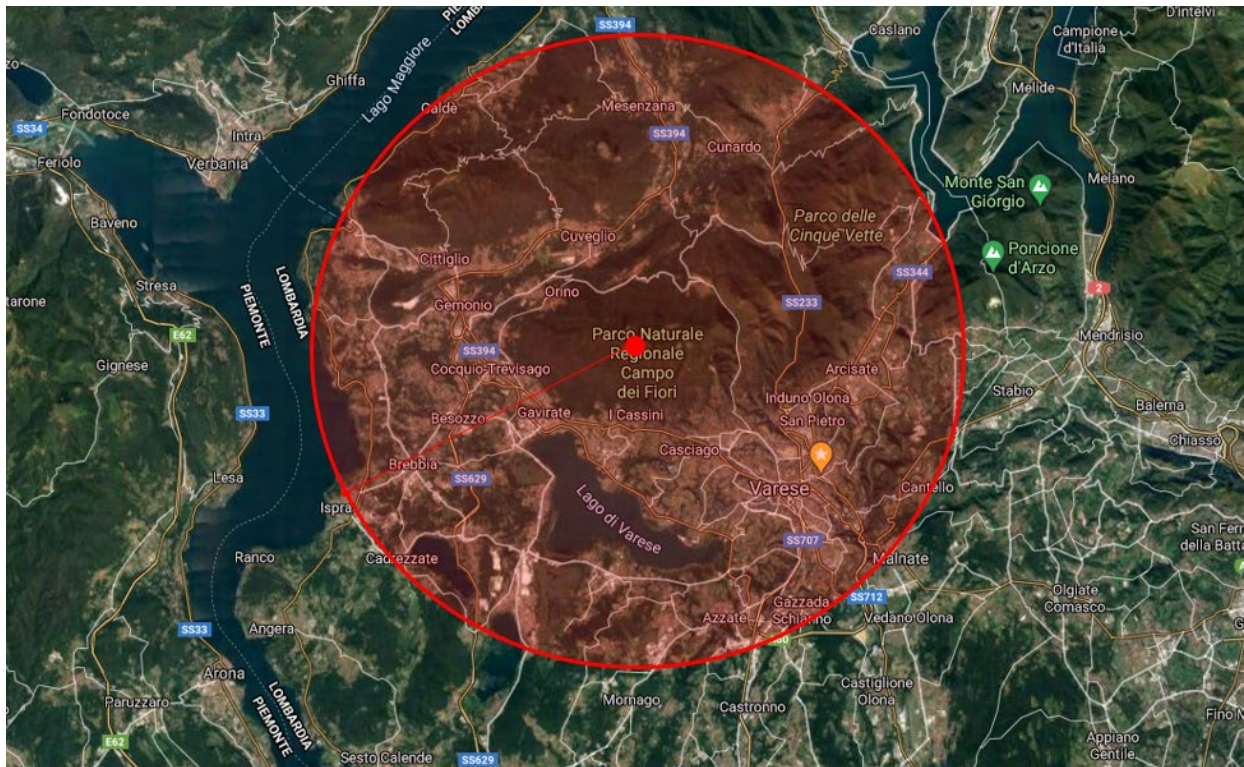

**Figure 45 C/N<sub>0</sub>, Receiver B, E6-BC signal, all satellites in view (Case 6)**

As it can be easily seen, the effect of the presence of the interfering signal is very evident on both receivers, and causing again a drop on the C/N<sub>0</sub> of about 3 dB in the case of Receiver A and about 10 dB for the receiver B for all satellites in view.

Provided that different receivers are affected to a different extent (typically as a function of their front-end filter bandwidth), it is evident that all those cases represent unacceptable degradation on all the receivers considered, and affecting all satellites in view, independently from their actual elevation. Indeed, the measured degradation is exceeding by far the commonly accepted indicator for an ongoing interference in the terminology of GNSS (as reported in the previous section) which is the decrease of the carrier-to-noise density  $C/N_0$  at the output of the tracking loop for every single satellite's signal by 1 dB.

As previously mentioned, the concerned Amateur Radio Repeater has been identified through its Ministerial identifier transmitted in an FM voice message and it is located in Campo dei Fiori (Varese), a hill dominating the area and located at about 15 km from the JRC Ispra site. The area is represented in the following figure, including markers for the JRC site location (Ispra), the approximate repeater location (Parco Naturale Regionale Campo dei Fiori) and the minimum concerned area (a circle of radius equal to the distance between JRC and the repeater). It is useful in this context to mention that the concerned area includes the main city of Varese and comprises a population which is well above the 100.000 inhabitants.



**Figure 46 Area Affected by the emission (as a minimum)**

The interfering events above described have been reported to the competent authorities in Italy (Ministero dello Sviluppo Economico, MISE) on 21st June 2021.

## ANNEX 7: STUDY TO EVALUATE POTENTIAL INTERFERENCE AREAS

### A7.1.1 Introduction

The aim of the study is to provide an assessment of the geographical extension of the interference cause by stations of the radio amateur service into Galileo E6 Receivers.

The methodology consists considering several types of radio amateur stations and calculating the area around them where the protection criterion of the Galileo E6 receiver would not be met.

### A7.1.2 Parameters of the radio amateur stations

The parameters of the radio amateur stations are given in section 2.1.5.

### A7.1.3 Propagation models

The propagation loss has been calculated using Recommendation ITU-R P.1546 [35]. The settings of the model are: type of terrain: land, area type: sub-urban. The height of the RNSS RX above ground is 1.5 m. Two values have been used for the clutter height: 10 m and 0 m (open land).

It has to be noted that when the clutter height is set to 0 m, the RNSS receiver gain is set to -6dB. On the other side, with a clutter height of 10 m and a receiver at 1.5 m above ground the direction of arrival of the main propagation path is usually, via diffraction for the clutter top. This means the elevation of arrival of the main propagation path could usually be above 5° and the assumption of using – 6 dB as the gain for the RNSS receiver can still be valid till around 10°.

The polarisation loss considered in this study is 3 dB.

### A7.1.4 Time variability effect

Due to the variation in the atmospheric conditions and propagation conditions, such as ducting, the interfering signals can show time variability. These phenomena are taken into account by Recommendation ITU-R. P. 1546 [35]. However, these time effects are mostly relevant over long distances, while at short distances they tend to be negligible. In the calculations it was decided to use 1% and 50% of time for paths.

### A7.1.5 Location variability effects

The other aspect to be considered is the spatial variability of the electromagnetic field. By the way it is conceived, a propagation usually gives the estimated median value of the received power in a given pixel of terrain. This is the case, for instance, of the curves given by Recommendation ITU-R P.1546 [35].

Inside this pixel of terrain, you can still have slow fading and fast fading. The effect of local statistical variations of the electro-magnetic (EM) field also needs to be taken into account.

In order to appreciate this fact, consider a pixel of terrain 50x50 m wide. Assume that the maximum tolerable interfering power for the RNSS receiver is  $P_{int}^{MAX}$ . In order to declare that the pixel is free from interference it is not sufficient to verify that the interfering received power from the radio amateur station, calculated with the chose propagation model, is equal or below  $P_{int}^{MAX}$ . For instance, when its value is exactly equal to  $P_{int}^{MAX}$  this means that 50% of the locations inside the pixel will be still be above this value. For this reason, the analysis of interference shall be conducted in such a way that, for a given pixel to be declared interference free, the interfering EM field shall be below the reference threshold for, say, X=99% of its locations.

It is therefore necessary to have the statistical model of the spatial variability of the EM field for a given pixel. In general, such a variation is composed of a slow variation (shadow fading) and fast variation (fast fading), that it due to multipath effects.

A characterization of the spatial variability of the field strength in various frequency bands and for different propagation scenarios (the clutter at the location of the RX plays a fundamental role), is described in Recommendation ITU-R P.1546-6, section 12 of Annex 5 [35].

Recommendation ITU-R P.1546 [35] gives curves of basic propagation loss for different location probabilities. The curve of propagation loss given for 50% of probability means that, for that given pixel, 50% of the locations will actually have a propagation loss lower than the value given by the model and 50% a propagation loss higher than that. If, on the other side one considers the curves referring to a location probability equal to 1%, this means that for a given pixel and a corresponding propagation loss, for 99% of the locations inside that pixel the propagation loss will be actually higher (and, therefore, interference lower).

In other words, if one calculates the contour of the interfered area with the model set at 50% location probability, the contour will be the focus where, for a pixel of terrain, say, 50x50 m wide, half of the surface will be interfered and half interference-free. Inside the contour, of course, the interference probability will be higher, and outside lower. On the other side, if one traces the contour with the model set at 1% location probability, the contour will be the focus where, for a pixel 50x50 wide, 99% of the locations inside that pixel will be interference free. Outside the contour the interference probability will be progressively higher, inside, progressively lower.

In this study both contours at 50% and 1% location probability are provided.

#### A7.1.6 Protection requirements of Galileo

The protection requirements of Galileo, together with parameters of the RNSS receiver, are specified in Recommendation ITU-R M.1902 [37].

The preliminary protection requirements are the following:

For a narrowband interfering signal ( $B_w < 128$  kHz) interfering the Galileo received in tracking mode: -134.5 dBW at the output of the RX antenna.

For a wideband interfering signal ( $B_w > 1$  MHz) interfering the Galileo received in tracking mode: -140 dBW/MHz at the output of the RX antenna.

The characteristics of the Galileo receiver are copied in the table below (as per Recommendation ITU-R M.1902-2 [37]).

**Table 55: Galileo RX parameters**

Parameter	Value	Notes
Polarisation	Circular	
Antenna gain upper hemisphere	3 dB	To be used from 5° to 90°
Antenna gain lower hemisphere	-6 dB	To be used for elevations up to 5°

For the study, the values of -134.5 dBW/ -140 dBW/MHz have been used, corresponding to the narrowband interferer and the wideband analogue ATV interferer, respectively. For the choice of the RNSS receiver antenna gain, see the section about the propagation model.

#### A7.1.7 Parameters of the radio amateur stations

Parameters for the radio amateur station vary significantly, both in terms of transmission power and type of signal.

Based on the information contained in section 2.1.5 the following ‘typical stations’ have been considered.

### A7.1.7.1 Amateur stations

Three set of parameters for the amateur stations have been considered (the power varying for each of the two types). They are given in the tables below.

**Table 56: Parameters for stations**

	Home station 1	Home station 2	Permanent installation
	Used also for Amateur Satellite Uplink communications with TX power of 1 W	Used only for Earth-Moon-Earth communications	
Parameters	Value		
Antenna	Single Yagi, 18 dBi gain, 18° 3 dB aperture	Dish (4m), 32 dBi gain, 4° 3 dB aperture	13 dBi gain, 60° 3 dB beam width
TX power	1 W, 100 W, 300 W	50 W	1 W
Antenna height above ground	12 meters	3 meters	25 meters
Polarisation	Linear	Linear	Linear

Further analysis could consider specific applications where very directive antennas are pointed in a direction that reduces the interference, such as Amateur Satellite Uplink or Earth-Moon-Earth communications. Such studies have also been done in this chapter, following the characteristics shown in Table 56.

The following figures give the graphical representation of the antennas' diagram using Recommendation ITU-R F. 1336-v5 [38].

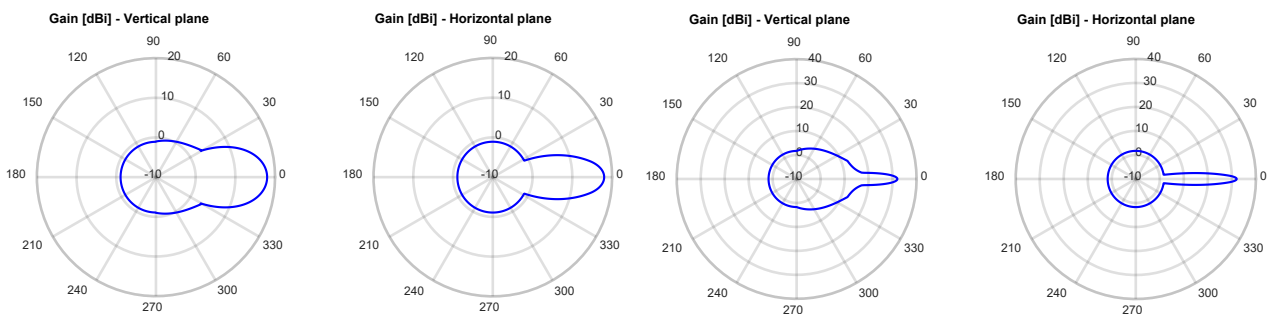

(a)

(b)

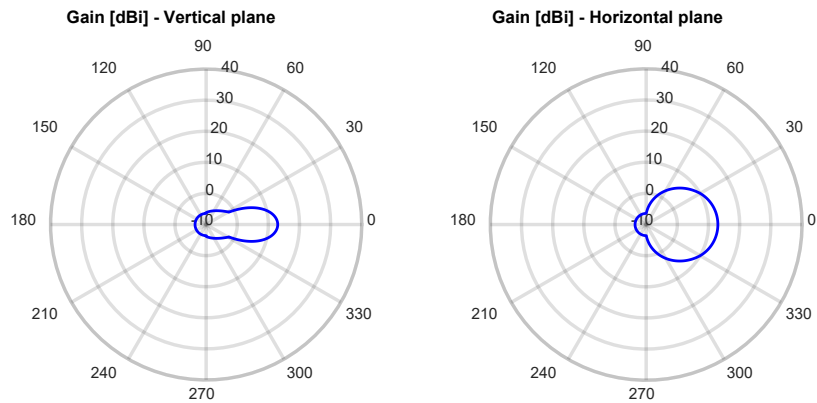

(c)

**Figure 47: Antenna diagrams (Recommendation ITU-R F. 1336 [38]): (a) Yagi antenna 18 dBi, 18° half beam width (Home station 1), (b) Antenna diagram (Home station 2) and (c) Antenna diagram (Permanent installation)**

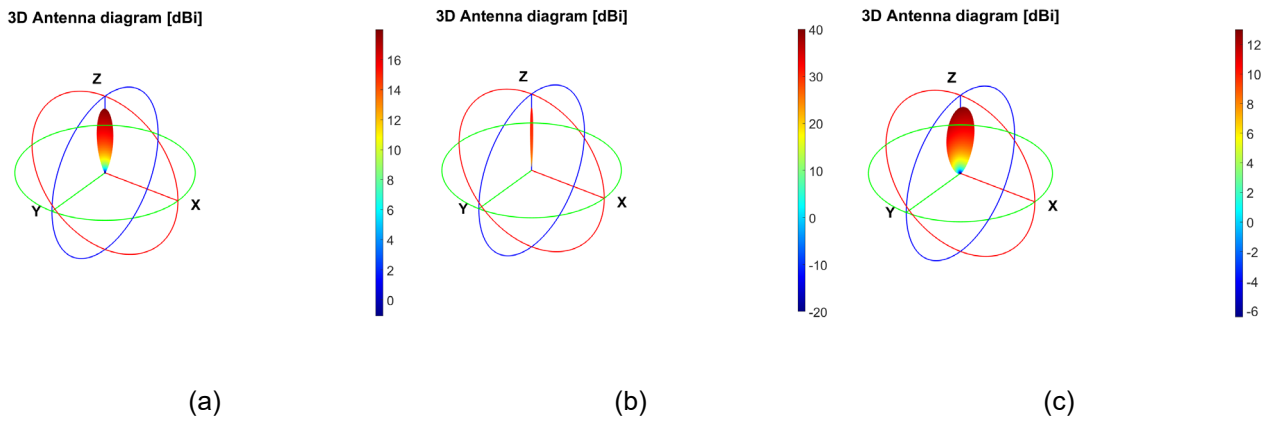

**Figure 48: 3D representation of the antenna’s diagram: (a) Home station 1, (b) Home station 2 and (c) Permanent installation. The permanent station is constituted by stations not installed at the home location of the radio amateur, used as relay and beacons**

For Amateur-Satellite-Uplink systems a more suitable antenna is ‘Home station 1’ considering a power of 1W. The amateur antennas, in this case, are pointed in the direction of the amateur satellite which will reduce the interference with RNSS receivers by several kilometres.

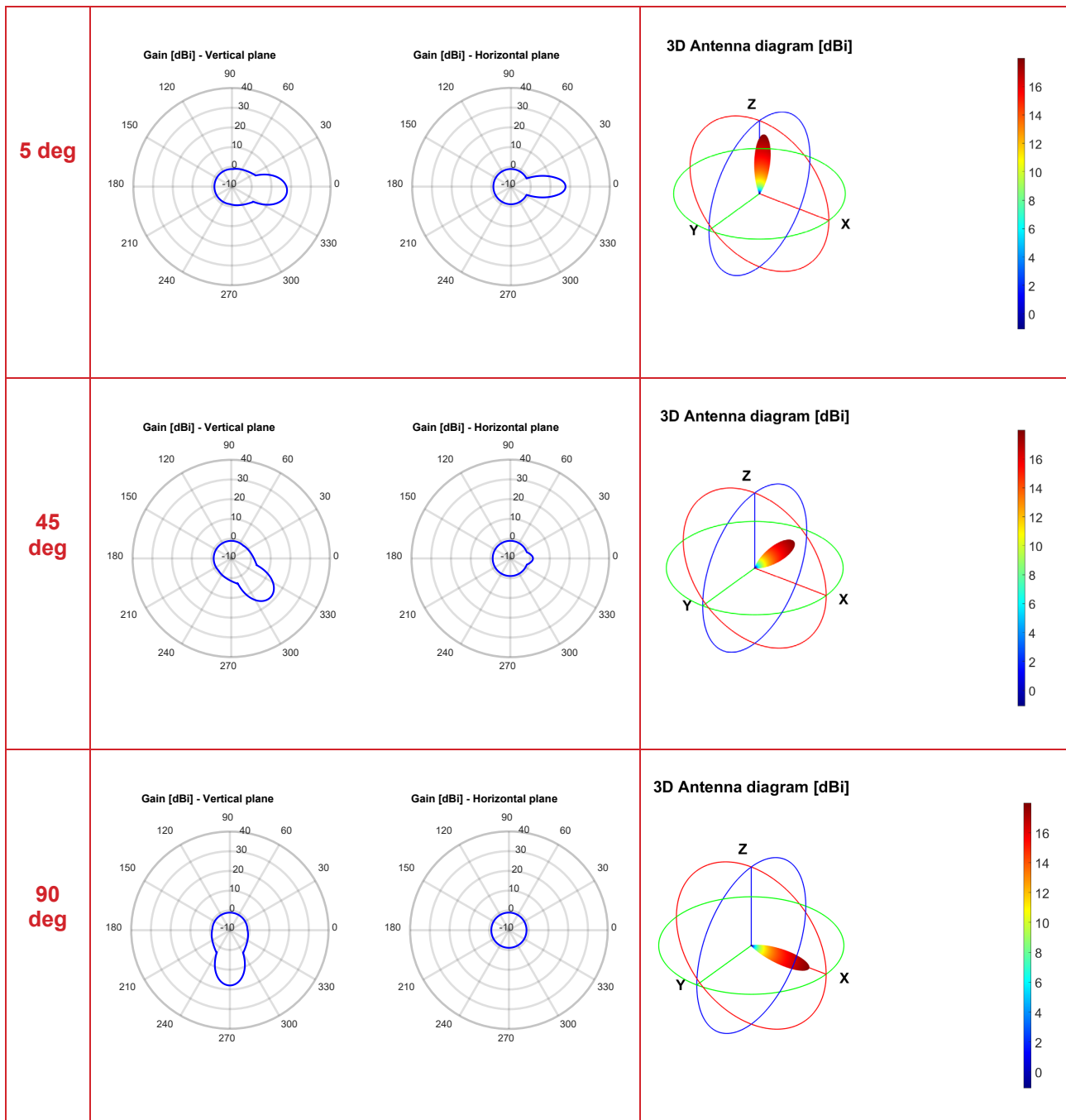

**Figure 49: Representation of the Home station 1 antenna diagram for different down tilt angles for Amateur-Satellite-Uplink communications**

For Earth-Moon-Earth (EME) communications, the directive antennas are pointed in the direction that reduces the interference. In this case, the station that could possibly be used for EME is Home station 2 because its characteristics respect the parameters considered in Table 56. Considering this, a study where Home station 2 has been orientated from an elevation angle of 5 degrees till 90 degrees has been presented below. This rotation will ensure that the signal will arrive to the Moon. Such a scenario could be useful for ensuring an interference decrease of various kilometres depending on scenario.

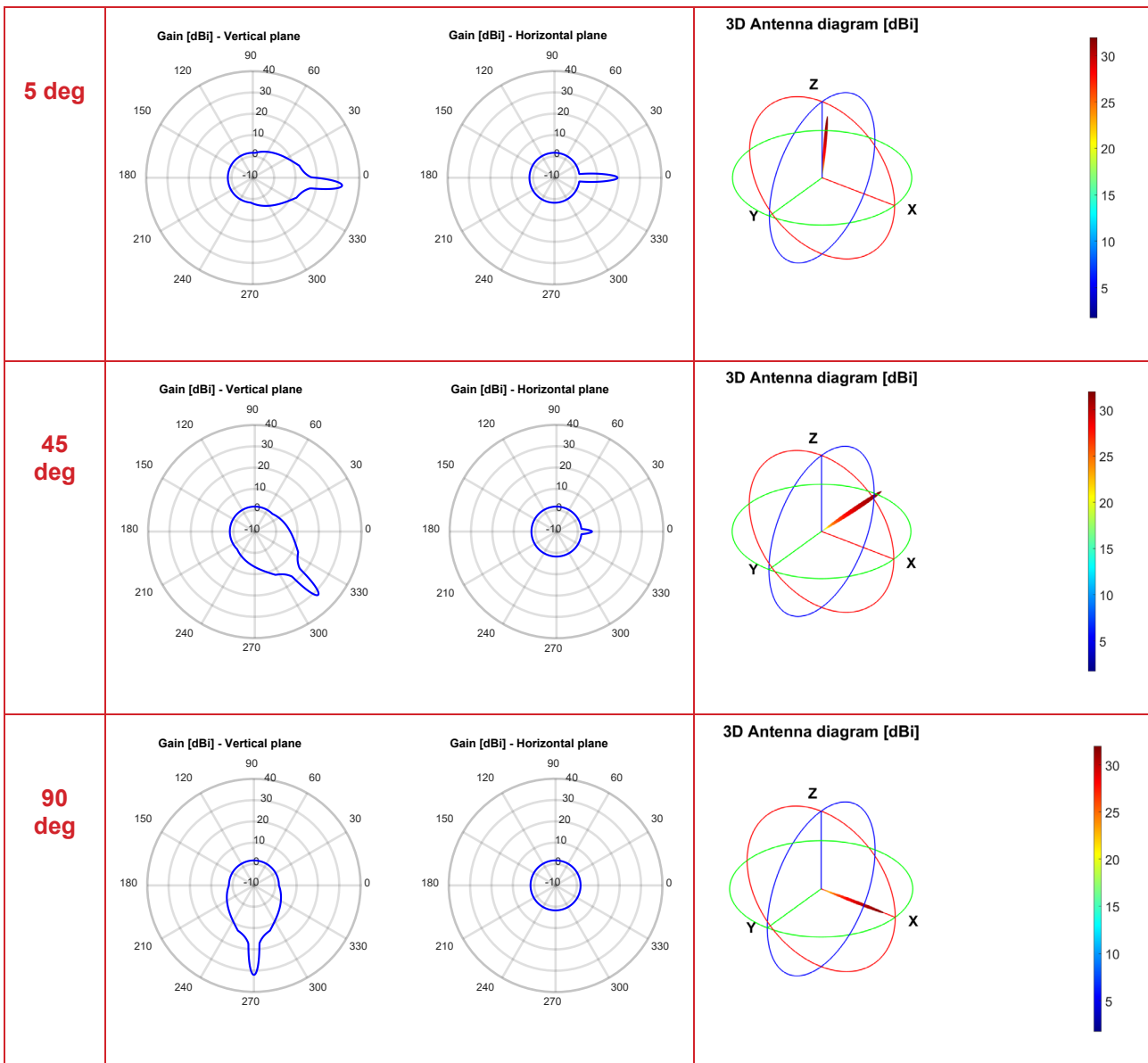

**Figure 50: Representation of the Home station 2 antenna diagram for different down tilt angles for EME communications**

**A7.1.8 Type of service and frequency overlap with the Galileo system**

As indicated above, Recommendation ITU-R M.1902 [37] prescribes two protection criteria, differing depending on whether the interfering signal is narrowband or wideband. However, the protection criteria for Galileo E6 receivers apply to the whole bandwidth of the Galileo E6 signal. Galileo protection criteria apply even if the interfering signal only falls partially inside the frequency band used by Galileo.

**A7.1.9 Results of simulations**

*A7.1.9.1 Home station 1*

The following set of figures represents the interfering received power for a 'Home station type 1' whose parameters are contained in Table 56, for different Tx powers and for different location probabilities (50% and 1%). It has to be noted that Recommendation ITU-R P.1546 [35] cannot be used for distances less than 1 km, and this is reflected in the circular area around the transmitter, with radius 1 km (in dark blue in the figures), where the Loss is not calculated.



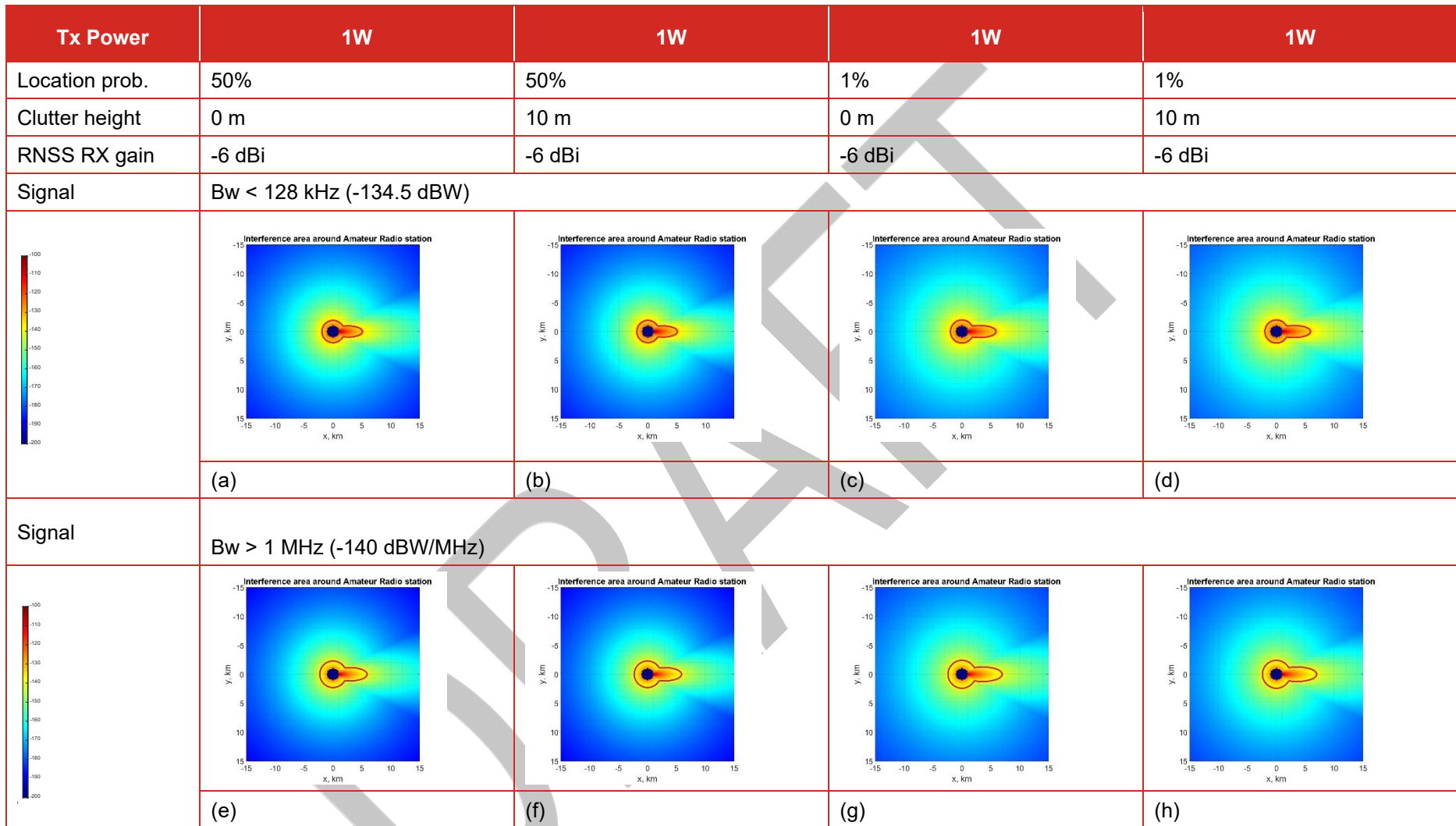

**Figure 51: Home station 1, sub-urban environment, Tx power 1 W using Recommendation ITU-R P.1546 [35]**

Following, for a Tx power of 100 W the same study will be made.



Tx Power	100 W	100 W	100 W	100 W
Location prob.	50%	5%	1%	1%
Clutter height	0 m	10 m	0 m	10 m
RNSS RX gain	-6 dBi	-6 dBi	-6 dBi	-6 dBi
Signal	Bw < 128 kHz (-134.5 dBW)			
				
	(a)	(b)	(c)	(d)
Signal	Bw > 1 MHz (-140 dBW/MHz)			
				
	(e)	(f)	(g)	(h)

Figure 52: Home station 1, sub-urban environment, Tx power 100 W using Recommendation ITU-R P.1546 [35]

A study for a radio amateur station transmission power of 300 W has also been done and the results can be seen below.

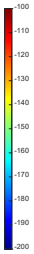
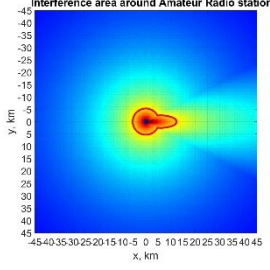
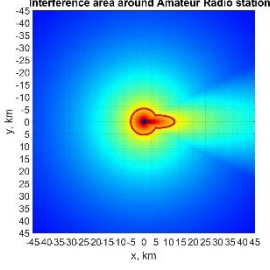
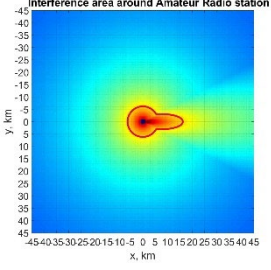
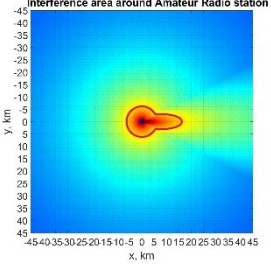
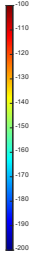
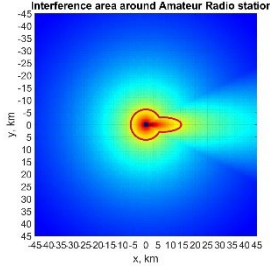
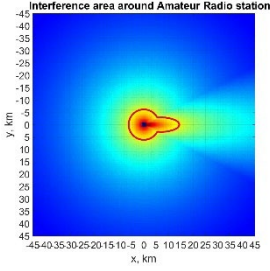
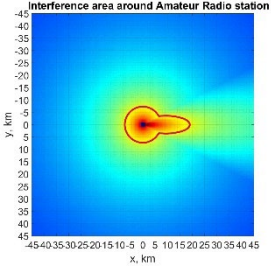
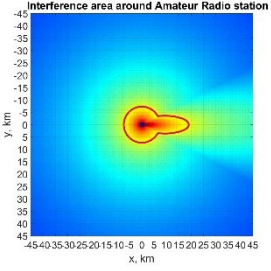

Tx Power	300 W	300 W	300 W	300 W
Location prob.	50%	50%	1%	1%
Clutter height	0 m	10 m	0 m	10 m
RNSS RX gain	-6 dBi	-6 dBi	-6 dBi	-6 dBi
Signal	Bw < 128 kHz (-134.5 dBW)			
				
	(a)	(b)	(c)	(d)
Signal	Bw > 1 MHz (-140 dBW/MHz)			
				
	(e)	(f)	(g)	(h)

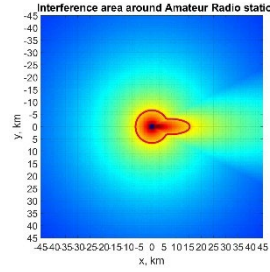
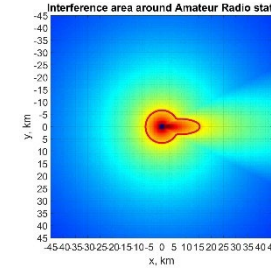
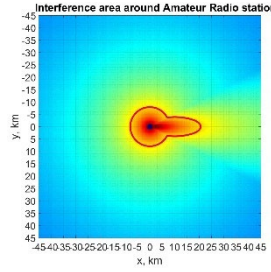
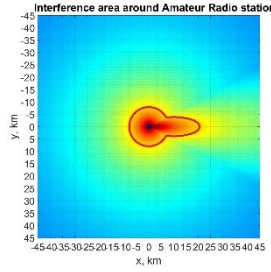
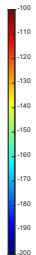
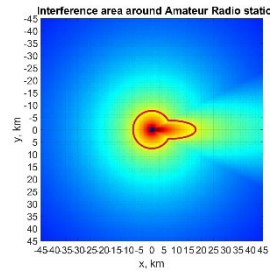
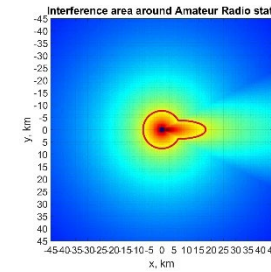
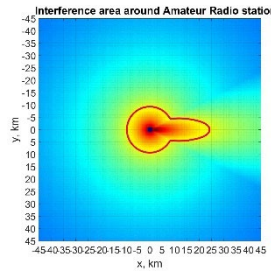
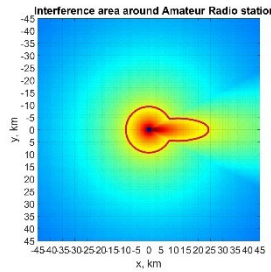
**Figure 53: Home station 1, sub-urban environment, Tx power 300 W using Recommendation ITU-R P.1546 [35]**

Home station-1, Amateur-Satellite-Uplink scenarios

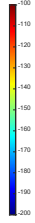
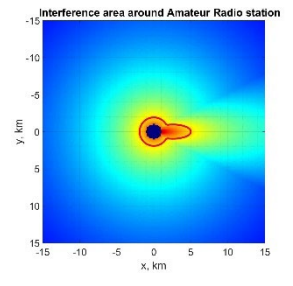
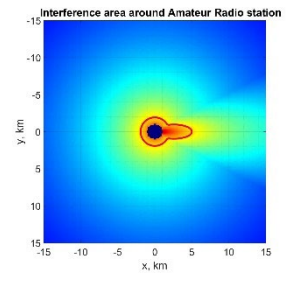
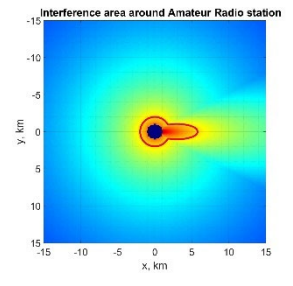
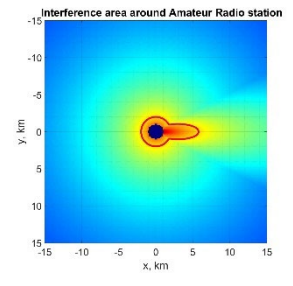
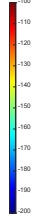
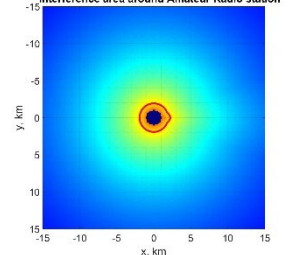
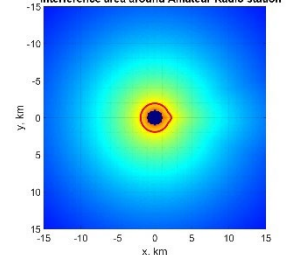
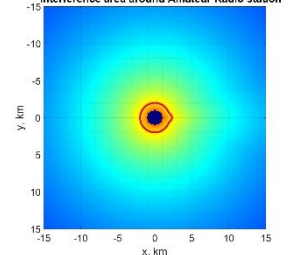
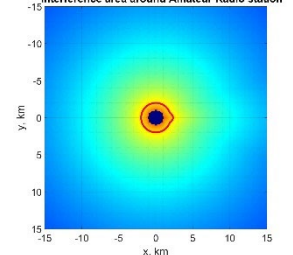
For Amateur-Satellite-Uplink scenarios, the same type of study has been performed with the difference that the down tilting antenna angle is different than 0 degrees in this case. The study considered for the Home station 1 a transmission power of 1W.

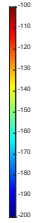
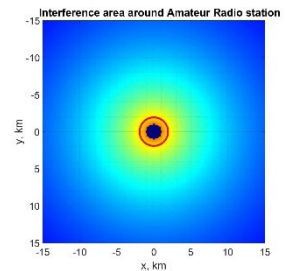
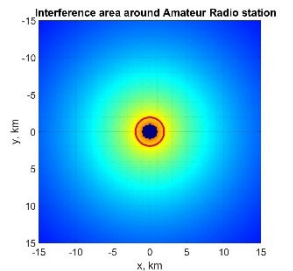
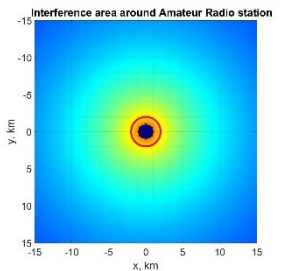
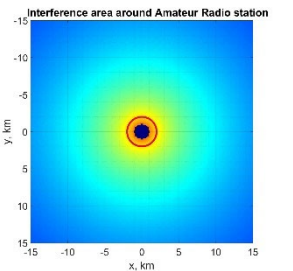
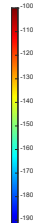
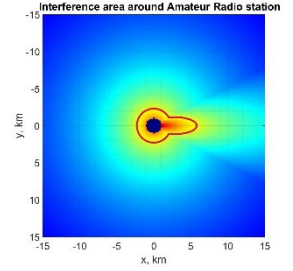
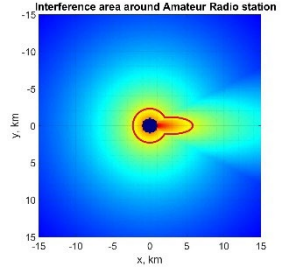
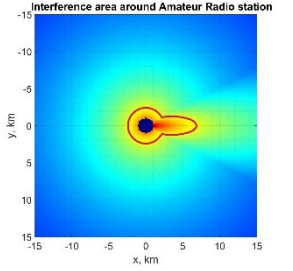
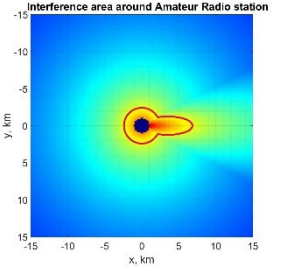
Tx Power	1W		1W		1W		1W	
Location prob.	50%		50%		1%		1%	
Clutter height	0 m		10 m		0 m		10 m	
RNSS RX gain	-6 dBi		-6 dBi		-6 dBi		-6 dBi	
Signal	Bw < 128 kHz (-134.5 dBW)							
Down tilt angle (elevation angle)	5 deg							
					(a)	(b)	(c)	(d)
Down tilt angle (elevation angle)	45 deg							
					(e)	(f)	(g)	(h)
Down tilt angle (elevation angle)	90 deg							

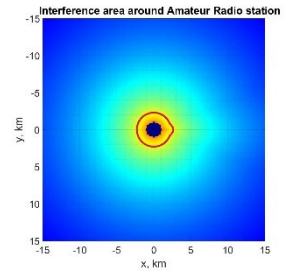
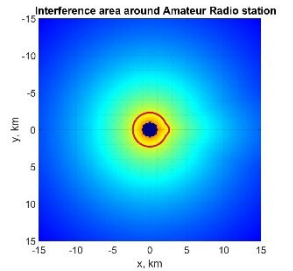
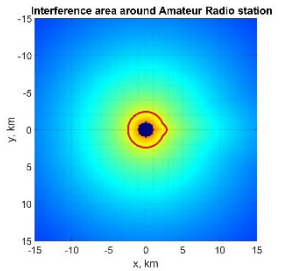
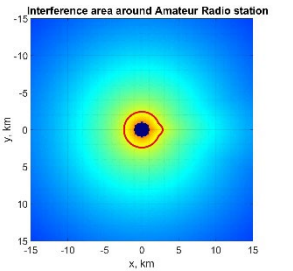
Tx Power	1W	1W	1W	1W
	 <p>(i)</p>	 <p>(j)</p>	 <p>(k)</p>	 <p>(l)</p>
Signal	Bw > 1 MHz (-140 dBW/MHz)			
Down tilt angle (elevation angle)	5 deg			
	 <p>(m)</p>	 <p>(n)</p>	 <p>(o)</p>	 <p>(p)</p>
Down tilt angle (elevation angle)	45 deg			
	 <p>(q)</p>	 <p>(r)</p>	 <p>(s)</p>	 <p>(t)</p>

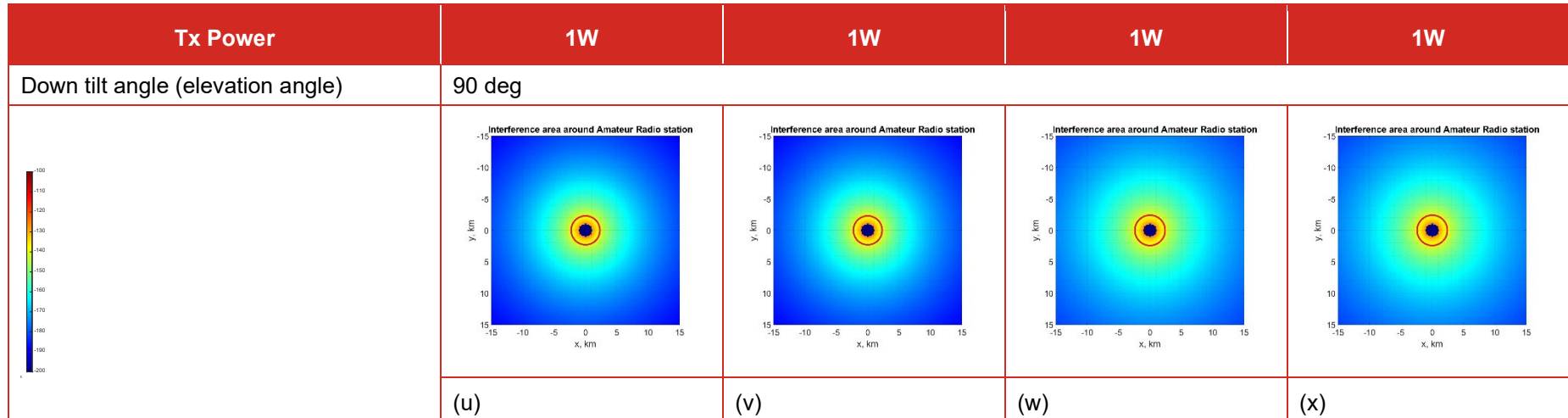

**Figure 54: Home station 1, sub-urban environment, Tx power 1 W for Amateur-Satellite-Uplink communications**

It is advantageous to orient the amateurs' antennas towards the amateur satellite both for RNSS and for the amateurs. It can be seen from the study realized that by changing the down tilt of the amateur antenna the interference area decreases significantly especially for high gain directive amateur antennas. For the amateur antenna 'Home station 1', it was seen that we can decrease the interferences by 1 km for a down tilt antenna angle of 5 degrees and by maximum 10 km for an angle of 90 degrees.

*A7.1.9.2 Home station 2*

Home station-2, Earth-Moon-Earth scenarios

For Earth-Moon-Earth scenarios a study has been performed where the antenna elevation angle is different from 0 degrees. The study considered for the 'Home station 2' has a transmission power of 50 W.

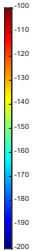
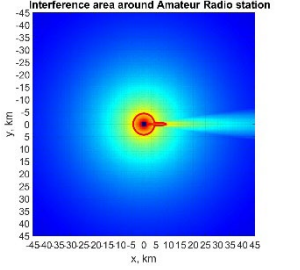
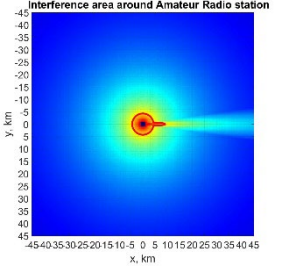
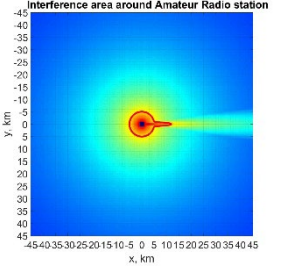
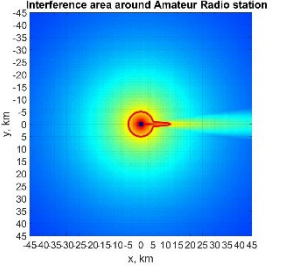
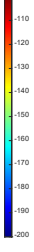
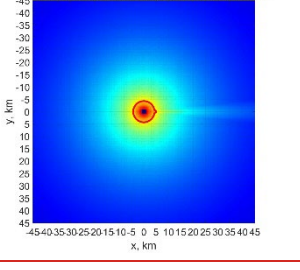
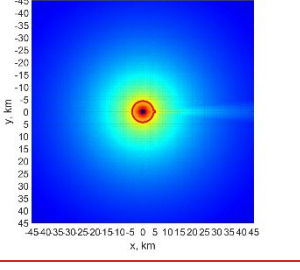
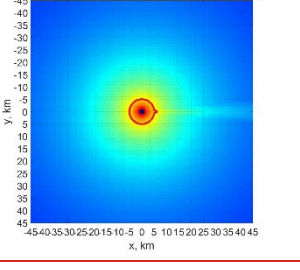
Tx Power	50 W	50 W	50 W	50 W
Location prob.	50%	50%	1%	1%
Clutter height	0 m	10 m	0 m	10 m
RNSS RX gain	-6 dBi	-6 dBi	-6 dBi	-6 dBi
Signal	Bw < 128 kHz (-134.5 dBW)			
Down tilt angle (elevation angle)	5 deg			
	 <p>Interference area around Amateur Radio station</p>	 <p>Interference area around Amateur Radio station</p>	 <p>Interference area around Amateur Radio station</p>	 <p>Interference area around Amateur Radio station</p>
	(a)	(b)	(c)	(d)
	Down tilt angle (elevation angle) 45 deg			
		 <p>Interference area around Amateur Radio station</p>	 <p>Interference area around Amateur Radio station</p>	 <p>Interference area around Amateur Radio station</p>
(e)		(f)	(g)	(h)
Down tilt angle (elevation angle) 90 deg				

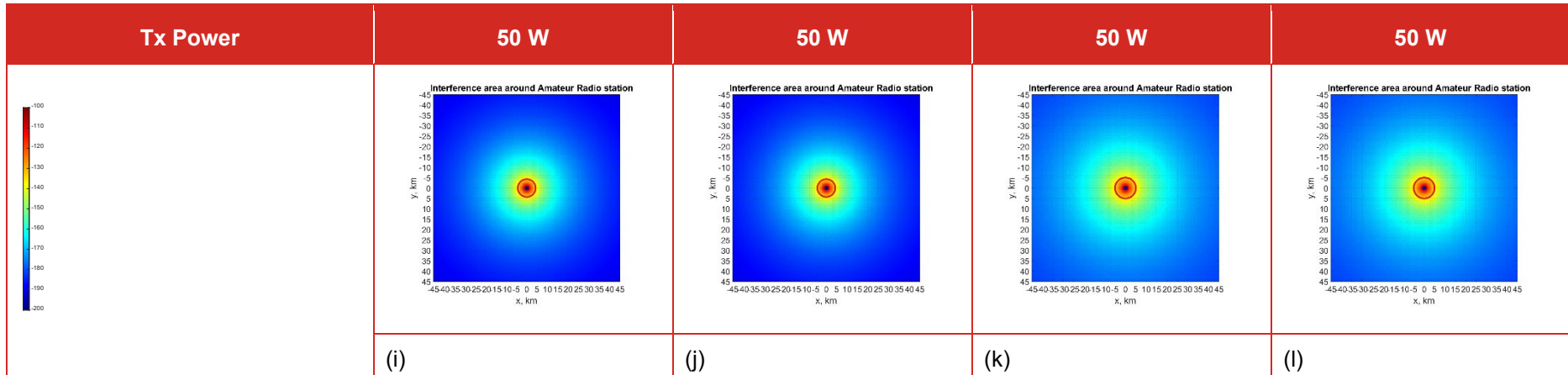

**Figure 55: Home station 2, sub-urban environment, Tx power 50 W for Earth-Moon-Earth communications**

It can be seen from the study realized that, by increasing the amateur antenna elevation angle, the interference area decreases significantly especially for high gain directive amateur antennas. For the amateur antenna 'Home station 2', it was seen that we can decrease the radius of the interference area by 5 km for an elevation of 5 degrees and by maximum 15 km for an elevation angle of 90 degrees. Furthermore, for directive antennas, it could be possible to decrease the interference around the amateur station depending on scenario.



A7.1.9.3 Permanent installation

Tx Power	1W	1W	1W	1W
Location prob.	50%	50%	1%	1%
Clutter height	0 m	10 m	0 m	10 m
RNSS RX gain	-6 dBi	-6 dBi	-6 dBi	-6 dBi
Signal	Bw < 128 kHz (-134.5 dBW)			
				
	(a)	(b)	(c)	(d)
Signal	Bw > 1 MHz (-140 dBW/MHz)			
				
	(e)	(f)	(g)	(h)

Figure 56: Permanent installation, sub-urban environment, Tx power 1 W using Recommendation ITU-R P.1546 [35]

### A7.1.10 Conclusions

The simulations indicate interference areas around radio amateur stations with an extent of several km, depending on the case.

Interferences around the amateur radio station are higher, by around 5 dB, for broadband signals.

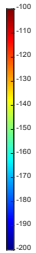
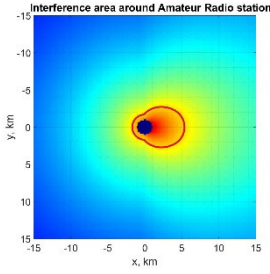
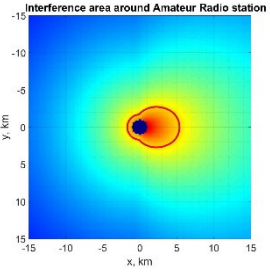
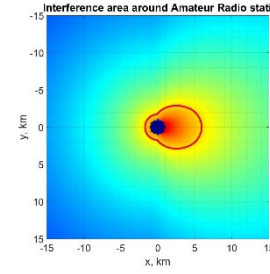
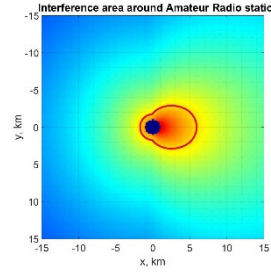
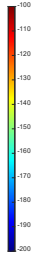
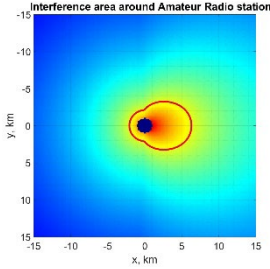
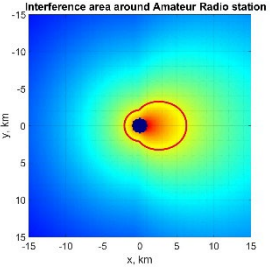
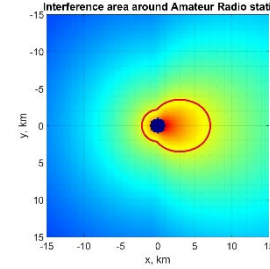
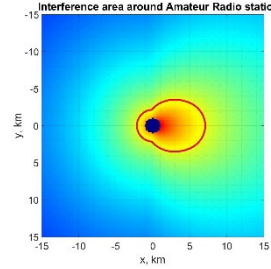
For all scenarios, if the TX power is increased, then the area where the RNSS protection criteria is exceeded also increases therefore potentially impacting more the RNSS receivers against possible interference. The studies predicated, for 'Home station 1', that for a transmission power of 300 W the highest interference distance of 20 km was obtained, while when 1W transmission power was used a maximum of 6.35 km interference distance was generated.

Depending on the scenario, for environments with cluttering, the interference distance between transmitter and receiver decreases by approximately 2km in comparison with no cluttering environments. This behaviour is normal because with cluttering the line-of-sight is not always visible and the interference is only obtained from the obstacle diffractions.

It was observed that the highest interference distance between transmitter and receiver, up to 20 km in the main beam direction, was obtained for 'Home station 1' where the maximum gain of the station was considered 18 dBi and a transmission power of 300 W was considered. It can also be noted that if the amateur radio station has a narrower 3dB beam width then the interference is at its highest in the direction of the maximum gain.

In Section 6, minimum coupling loss studies have also been conducted considering different frequency bands and amateur type of applications.

## ANNEX 8: STUDY TO EVALUATE THE POSSIBILITY OF USING THE BANDS 1293-1294 MHZ OR 1293.845-1294.345 MHZ FOR AMATEUR APPLICATIONS

For narrowband FM amateur applications, a possible frequency band to be used could be 1293-1294 MHz or 1293.845-1294.345 MHz. The section below is dedicated to the studying the impact of these frequency bands on Galileo receivers, considering the exact waveform of the signal BPSK.

A first band 1298-1300 MHz was recognized as to be used by FM amateur stations but this band might not be sufficient for realizing the transmission and emission so a second frequency band needs to be detected and potentially this band could be 1293-1294 MHz or 1293.845-1294.345 MHz.

In the figure below, the BPSK and BOC signals identified for Galileo as represented and normalized with respect to the protection criteria for narrowband signals as defined in Recommendation ITU-R M.1902 [37]. This normalisation was performed in order to determine what is the protection criteria depending on the waveform where the peak was considered at 1278.75 MHz. Using the exact waveform, it is possible to determine the exact impact of an amateur station in a specific frequency band. Still, the protection criteria for RNSS receivers is constant in the entire defined frequency band as specified in Recommendation ITU-R M.1902-2 [37] but for a better understanding of the effect of an amateur station on the Galileo receivers a very specific case was considered here.

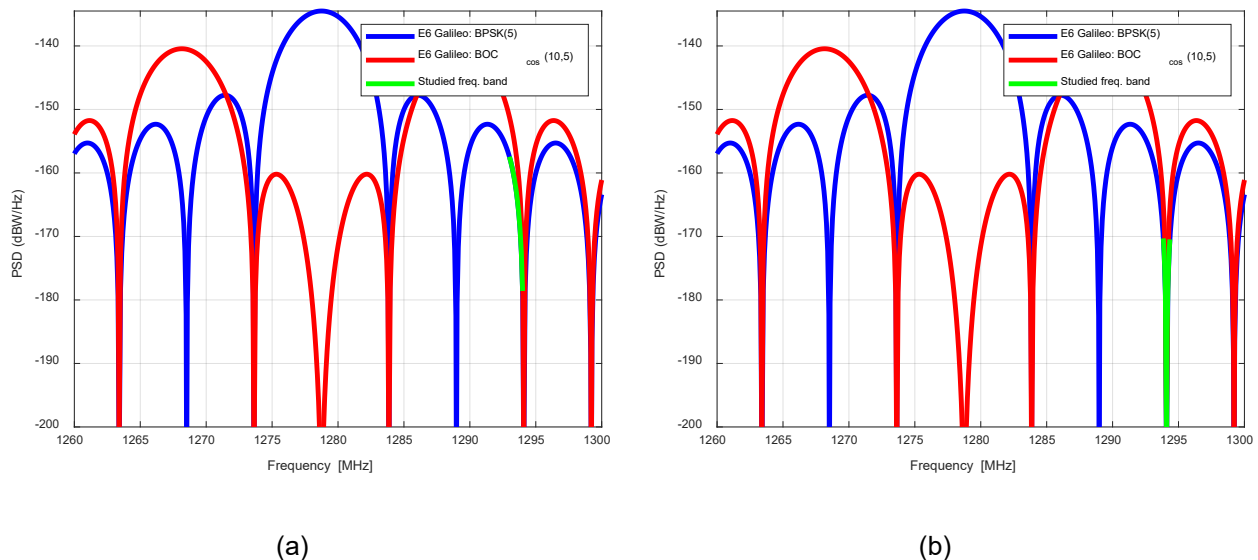

**Figure 57: Power Spectral Density (PSD) of the Galileo E6 signal baseline normalized with respect to the protection criteria for narrowband signals as defined in Recommendation ITU-R M.1902 [37], Studied frequency band (a) 1 293-1 294 MHz and (b) 1 293.845-1294.345 MHz**

The same methodology as described in section 5 was considered where the maximum distance where interference that can be detected was determined in the main lobe of the amateur station depending on amateur transmission power. The main parameters for the study were as follows:

- No cluttering has been considered;
- On the RNSS side, an antenna with a gain of -6 dBi located at 1.5 meters from the ground has been used;
- The protection criterion of Galileo was considered to be -134.5 dBW (Recommendation ITU-R M.1902 [37]) for narrowband applications;
- On the amateur side, the maximum antenna gain was considered, 18 dBi
- The polarisation loss used was 3 dB;
- The studies have been done in a suburban area with a location probability of 50%.

Considering the parameters above, in Figure 58, the maximum distance where interference was detected and the IEL for 'Home station 1' were represented. Since the protection criteria of Galileo is not constant anymore

and doesn't have the value of -134.5 dBW considering the normalization at the central frequency, then in the frequency band 1293-1294 MHz the protection criteria will be less stringent by about 20 dB.

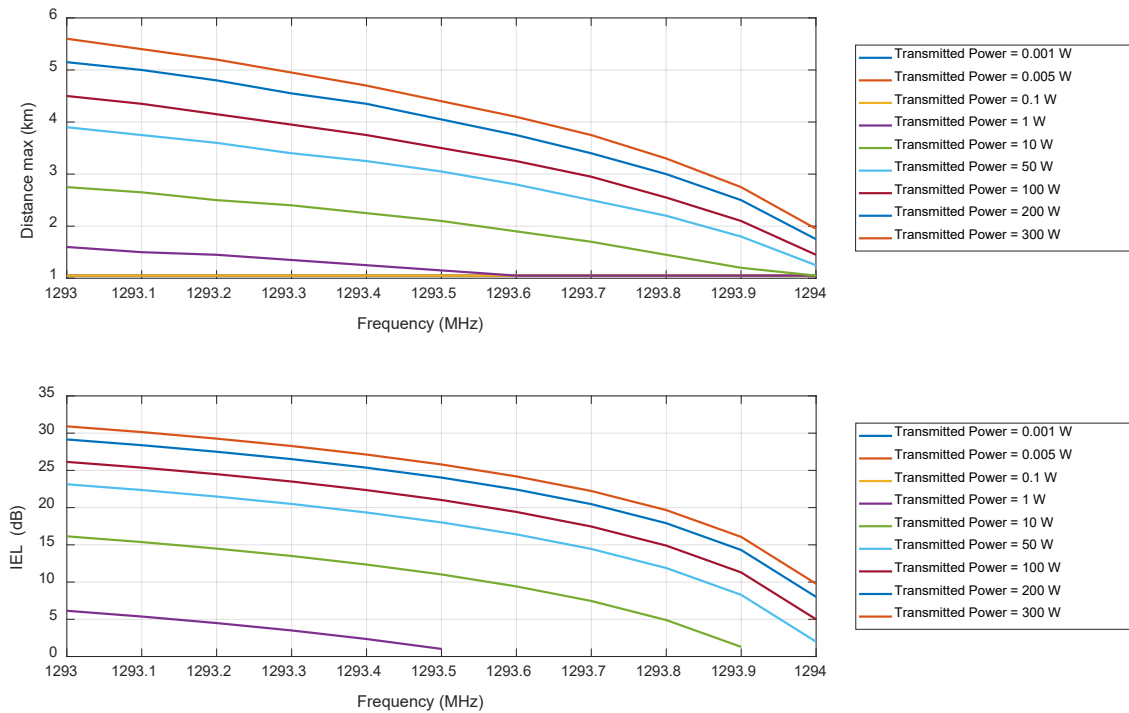

(a)

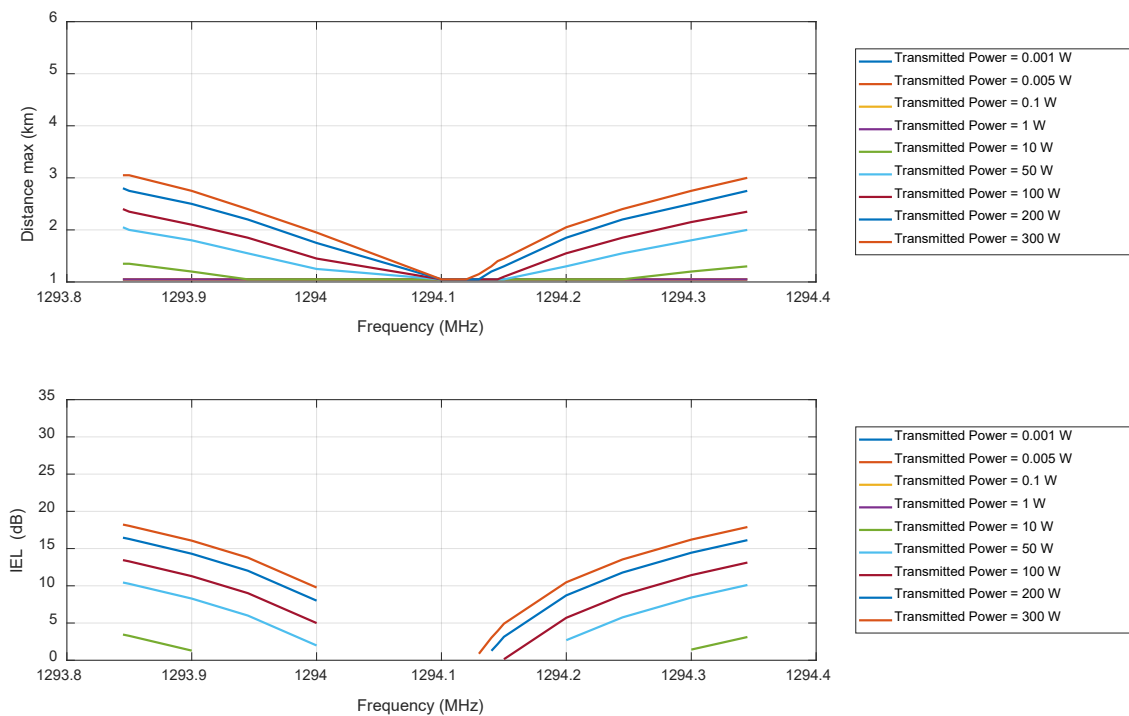

(b)

**Figure 58: Maximum distance of interference and IEL (fixed distance of 1 km) in the band 1293-1294 MHz taking into account the exact PSD as represented in Figure 57 (green curve) using Home station 1. Studied frequency band: (a) 1 293-1 294 MHz and (b) 1 293.845-1294.345 MHz**

Figure 58(a) depicts very well the impact that the less stringent protection criteria can have in the frequency band 1 293 - 1 294 MHz on RNSS receivers. The values above can be compared with the ones from and Table 18. In Table 18, considering the constant protection criteria of Galileo the maximum distance where interference is observed in the frequency band 1 293-1 294 MHz arrives to 8.15 km for a transmission power of 10 W but here a maximum interference till 2.75 km at 10 W is achieved because of the 20 dB less stringent protection criteria that depends on frequency. There is a decrease of around 5.4 km which could make the coexistence in between the Galileo receivers and amateur stations less problematic. Furthermore, at a distance of 1 km from the amateur station an IEL of maximum 15 dB is detected with a transmission power of 10 W.

Figure 58(b) describes also the case when the studied frequency band is 1 293.845-1294.345 MHz. The protection criteria of Galileo have a decrease of approximately 35.5 dB in this case, resulting in interference till 1.35 km for a transmission power of 10 W and an IEL of around 4 dB maximum.

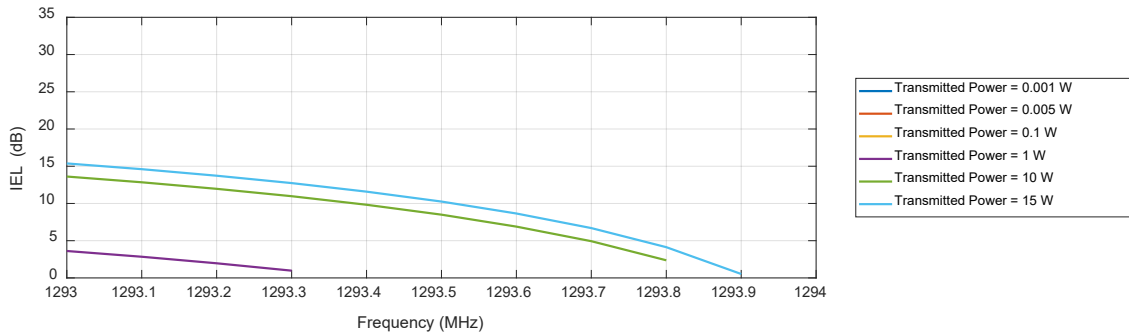
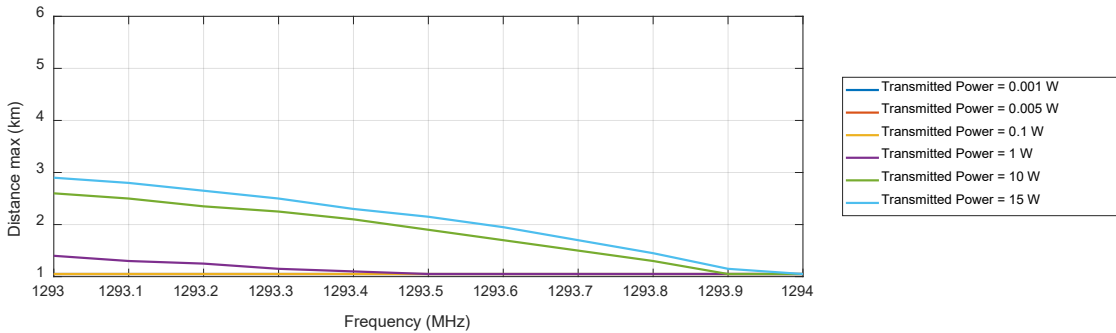

(a)

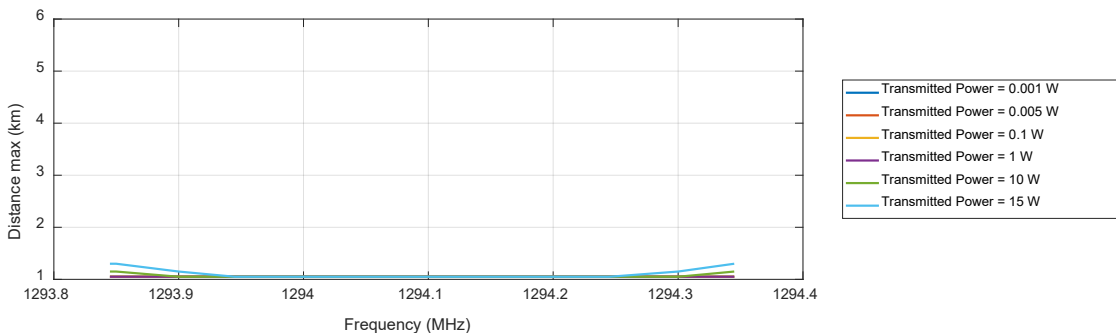

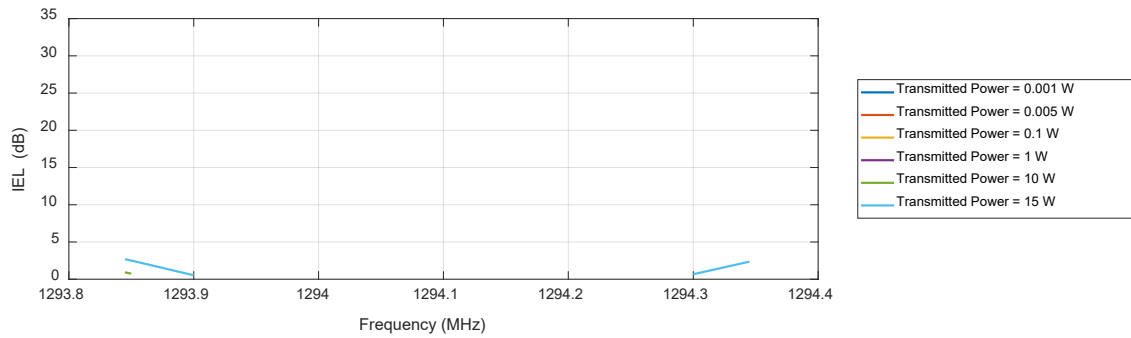

(b)

**Figure 59: Maximum distance of interference and IEL (fixed distance of 1 km) in the band 1293-1294 MHz taking into account the exact PSD as represented in Figure 57 (green curve) using Permanent station. Studied frequency band: (a) 1 293-1 294 MHz and (b) 1 293.845-1294.345 MHz**

The same study has been performed but using a Permanent amateur station in this case, as described in Figure 59. Permanent amateur stations can also decrease the effect of interference because their locations are well known and additional measures can be taken for avoiding interference. Considering that Permanent stations emit with a maximum e.i.r.p of around 300 W then using an amateur antenna station with a gain of 13 dBi it was possible to determine the exact maximum transmission power that arrives to around 16 W. Using the same comparison as above in between, Table 18 and Figure 59(a) there is a decrease of interference of about 5.15 km and an IEL of 14 dB which might make the coexistence in between the two systems (RNSS and amateurs) more likely.

Furthermore, for the case when the 1 293.845-1294.345 MHz was studied, considering the decrease by 35.5 dB for the Galileo protection criteria depending on frequency band, then there is interference till around 1.2 km with an IEL of 2 dB which, depending on the case, can conduct to a higher possibility for coexistence in between the two systems.

### A9.1 Conclusions

Two possible frequency bands were studied: 1293-1294 MHz and 1293.845-1294.345 MHz. For each frequency band the constant protection criteria of Galileo given in Recommendation ITU-R M.1902-2 [37] has been normalized depending on the waveform of the Galileo system. This normalization has been performed in order to show that by increasing the offset from the central frequency of Galileo there is a better chance of coexistence in between RNSS and the amateurs service.

From the results obtained, it was determined that a better coexistence in between RNSS and the amateur service can be achieved in the frequency band 1293.845-1294.345 MHz with interference arriving till 3 km and an IEL of 18 dB for 'Home station 1' in the case where the amateur station transmits with 300 W. In the case for amateur 'Permanent stations' the interference can arrive till 1.2 km with an IEL of around 4 dB at an amateur transmission power of 15 W.

## ANNEX 9: LIST OF REFERENCES

- [1] European Union, "Galileo Open Services Signal in Space Interface Control Document (OS SIS ICD)"; <http://ec.europa.eu/growth/sectors/space/galileo/>; 2016
- [2] "Compatibility between Amateur Radio Services and Galileo in the 1260-1300 MHz Radio Frequency Band", Issue 1.1, European Commission, Joint Research Centre 2015 ([FM44\(19\)017](#))
- [3] "Compatibility between Amateur Radio Services and GALILEO in the 1260- 1300 MHz Radio Frequency band". JRC Scientific and Policy Reports, Issue 1.1 2015
- [4] "Coexistence measurements: amateur radio service and Galileo E6 in the frequency range 1260 – 1300 MHz", Measurement report G 001/00261/18 and G 531/00282/18 BNetzA, Germany (PTA(19)032)
- [5] Recommendation ITU-R M.1787-3: Description of systems and networks in the Radio Navigation-Satellite Service (space-to-Earth and space-to-space) and technical characteristics of transmitting space stations operating in the bands 1 164-1 215 MHz, 1 215-1300 MHz and 1 559-1 610 MHz", International Telecommunication Union, Geneva, 2018
- [6] The International Amateur Radio Union, IARU Region 1 band plan for 1240 - 1300 MHz (Landshut, 2017); <https://iaru-r1.org/index.php/spectrum-andband-plans/uhf/23-centimeter>; last accessed: 2019-01-21
- [7] "Binary Offset Carrier Modulations for Radionavigation" John Betz, Journal of the Institute of Navigation (IoN), Vol. 48, No 4, Winter 2001/2002, USA,
- [8] "Effect of Narrowband Interference on GPS Code Tracking Accuracy", John Betz, ION NTM 2000, 26-28 January 2000, Anaheim, CA
- [9] "Effect of Partial-Band Interference on Receiver Estimation of C/No: Theory", J. Betz, MITRE Report, 2006
- [10] "GNSS Disruptions," in GNSS technology and applications series, Understanding GPS/GNSS: Principles and applications, E. D. Kaplan and C. J. Hegarty, Eds., Boston, London: Artech House, 2017, pp. 549–617
- [11] „A Dual-Frequency Interference Suppression Unit for E1/E5a Designed with National Instruments Software Defined Radios", Kraus T., Sailer S., Eissfeller B., Presentation at ION GNSS+2015, 17.09.2015, Tampa, Florida, USA
- [12] "Modul zur Unterdrückung von Störsignalen für globale Navigationssysteme mit NI SDR", Kraus T., Sailer S., Eissfeller B., In: R. Jamal, R. Heinze (Hrsg.): Virtuelle Instrumente in der Praxis 2015. Begleitband zum 20. VIP-Kongress, VDE Verlag 2015, pp. 43-46
- [13] "Auswerten von CPU-gestützten Algorithmen zur Störsignalunterdrückung im GNSS-Bereich und FPGA-Implementierung eines SDRs", Sailer S. Diplomarbeit, Hochschule Mittweida, 2015
- [14] COMMISSION IMPLEMENTING DECISION (EU) 2017/224 of 8 February 2017 setting out the technical and operational specifications allowing the commercial service offered by the system established under the Galileo programme to fulfil the function referred to in Article 2(4)(c) of Regulation (EU) No 1285/2013 of the European Parliament and of the Council
- [15] "Galileo E6-B/C Codes" Technical Note; January 2019
- [16] "The Particular Importance of Galileo E6C", J. Curran, T. Melgrad, insideGNSS, vol. September/October 2016, pp. 57-63
- [17] "GNSS Antennas: An Introduction to Bandwidth, Gain pattern, Polarisation and all that", G.J.K. Moernaut, D. Orban, GPS World
- [18] "State of the Art leading Edge Geodetic Antennas from Leica Geosystems", Leica Geosystems, Leica GNSS Reference antennas (White Paper)
- [19] "GNSS antennas RF design considerations for u-blox GNSS receivers Application note UBX-15030289-R03", u-blox AG, October 2019
- [20] "Antenna Survey 2018", GPS World
- [21] "Galileo E6-B/C Codes" Technical Note; January 2019 - available at [www.gsc-europa.eu](http://www.gsc-europa.eu)
- [22] GNSS Market Report, GSA Issue 5 2017
- [23] Global Navigation Space Systems: reliance and vulnerabilities, The Royal Academy of Engineering, 2011
- [24] Russian Space Systems, "Global Navigation Satellite System Interface Control Document (GLONASS ICD), Navigational radiosignal in bands L1, L2"; 2008
- [25] Russian Space Systems, "Global Navigation Satellite System Interface Control Document (GLONASS ICD), General Description of Code Division Multiple Access Signal System"; 2016
- [26] Parsons, The Mobile Radio Propagation Channel, 2nd Edition, Wiley.

- [27] IARU R1 VHF Handbook [https://www.iaru-r1.org/wp-content/uploads/2021/03/VHF\\_Handbook\\_V9.01.pdf](https://www.iaru-r1.org/wp-content/uploads/2021/03/VHF_Handbook_V9.01.pdf)
- [28] D-STAR: <https://icomuk.co.uk/What-is-D-STAR>
- [29] DMR: [https://en.wikipedia.org/wiki/Digital\\_mobile\\_radio](https://en.wikipedia.org/wiki/Digital_mobile_radio)
- [30] Fusion: <http://systemfusion.yaesu.com/what-is-system-fusion/>
- [31] ITU-R Recommendation M.2164: "Guidance on technical and operational measures for the use of the frequency band 1240-1300 MHz by the amateur and amateur-satellite service in order to protect the radionavigation-satellite service (space-to-Earth)"
- [32] ITU-R Report M.2513: "Studies regarding the protection of the primary radionavigation-satellite service (space-to-Earth) by the secondary amateur and amateur-satellite services in the frequency band 1 240 - 1 300 MHz"
- [33] ITU-R Report M.2532: "Amateur and amateur-satellite services characteristics and usage in the 1 240 - 1 300 MHz frequency band"
- [34] Recommendation ITU-R. P.1812: "A path-specific propagation prediction method for point-to-area terrestrial services in the frequency range 30 MHz to 6 GHz"
- [35] Recommendation ITU-R P.1546: "Method for point-to-area predictions for terrestrial services in the frequency range 30 MHz to 4 000 MHz"
- [36] [ECC Report 252](#): "SEAMCAT Handbook Edition 2", approved April 2016, The most recent version of the SEAMCAT handbook can be found online at [SEAMCAT Handbook](#)
- [37] Recommendation ITU-R M.1902-2: "Characteristics and protection criteria for receiving earth stations in the radionavigation-satellite service (space-to-Earth) operating in the band 1 215-1 300 MHz"
- [38] Recommendation 1336 (1336-5): "Reference radiation patterns of omnidirectional, sectoral and other antennas for the fixed and mobile service for use in sharing studies in the frequency range from 400 MHz to about 70 GHz"
- [39] Recommendation ITU-R P.452: "Prediction procedure for the evaluation of interference between stations on the surface of the Earth at frequencies above about 100 MHz"