



ECC Report **331**

Efficient usage of the spectrum at the border of CEPT countries between TDD MFCN in the frequency band 3400-3800 MHz

approved 05 November 2021

0 EXECUTIVE SUMMARY

This Report addresses cross-border coordination for MFCN (including AAS BS and non-AAS BS¹) in the following operation modes:

- 1 Synchronised operation²
- 2 Unsynchronised operation with partial duplex misalignment and ECC Recommendation (20)03 recommended scenario³ with Downlink Symbol Blanking (DSB)
- 3 Unsynchronised operation with partial duplex misalignment and ECC Recommendation (20)03 recommended scenario without DSB
- 4 Fully-unsynchronised operation (100% duplex misalignment) without preferential frequency blocks
- 5 Fully-unsynchronised operation (100% duplex misalignment) with preferential frequency blocks

Two interference mitigation solutions, downlink symbol blanking and sub-band blanking, are investigated and described. The inter-operability, impact on coverage and DL/UL capacity loss, implementation zone, etc. are analysed for these mitigation solutions.

Downlink symbol blanking (DSB) is a feature implemented in the 5G NR system allowing the base stations' schedulers to switch off transmissions ("blanking") of those downlink symbols ("blanked DL symbols") of each network that correspond to simultaneous uplink reception or simultaneous gap symbols for the other network, to avoid downlink to uplink interference. DSB is a base station scheduler feature applied to base stations in the geographical "DSB implementation zone". It does not require standardisation by 3GPP and is product-implementation dependent. At the time of writing, it is anticipated that there should not be any interoperability problem between different vendors when DSB is implemented according to the recommended scenario in ECC Recommendation (20)03. When using any of the two frame structures (frame A and B) recommended in ECC Recommendation (20)03, the impact of downlink symbol blanking on DL capacity is evaluated as 17.3% DL capacity loss when DSB is implemented by blanking both traffic and control channels. The downlink symbol blanking can have some impact on 5G-NR coverage as well in some cases although this has not been quantified in this report. DSB is not expected to be implemented for LTE-TDD in a near future and therefore its anticipated performance impacts on channel estimation due to the blanking of the LTE Cell-specific Reference Signal have not been quantified in this Report.

Another mitigation technique called sub-band (SB) blanking has been assessed in this Report. This technique relies on avoiding different duplex directions on the same resource blocks at the border. It enables a configurable trade-off between UL and DL capacity loss due to blanking. However, even though it avoids the high interference that would result from different duplex directions on the same resource blocks, it does not avoid interference between adjacent resource blocks. Further studies and possible standardisation work are still required to determine the feasibility (e.g. with regards to blocking and unwanted emissions), the exact size of the guard band, the residual cross-link interference, and implementation complexity at the base station, noting that there are currently no requirements defined in 3GPP specifications to address either co-channel adjacent resource-block interference or blocking. SB blanking is therefore considered not yet ready as a mitigation technique and no corresponding field strength values have been derived in this Report.

In the objective to derive the operational field strength trigger values for each of the five cross-border operation modes, realistic assumptions for MFCN networks including AAS BS and non-AAS BS system parameters and deployment scenarios have been established and described in ANNEX 1. Based on these assumptions, cross-border network interference Monte Carlo simulations for the five cross-border operation modes have been carried out for the following three cases:

¹ In this Report, it is assumed that non-AAS BS are using the 4G/LTE technology and AAS BS are using 5G/NR technology

² See ECC Report 216 [3] and ECC Report 296 [4].

³ ECC Recommendation (20)03 recommended scenario assumes frame A is used in one country and frame B in the other country and implies agreement on a common phase clock reference and partial duplex misalignment.

- 1 AAS BS to AAS BS (5G to 5G);
- 2 AAS BS to non-AAS BS (5G to 4G);
- 3 non-AAS BS to AAS BS (4G to 5G).

In this Report the assumption was made that the case of non-AAS BS to non-AAS BS will not happen in the future in the frequency band 3400-3800 MHz since the market is 5G NR driven.

The interference simulation methodology and the simulation results are described in ANNEX 2:.

Three types of field strength values are derived from the simulation results for AAS BS:

- Median data field strength value in $\text{dB}\mu\text{V}/\text{m}/(5 \text{ MHz})$, obtained by simulating the behaviour of AAS BS with beamforming AAS model;
- Maximum data field strength value in $\text{dB}\mu\text{V}/\text{m}/(5 \text{ MHz})$, obtained by using the maximum antenna gain, i.e., assuming the AAS main beam is always pointing to the borderline. This data field strength value gives the upper bound field strength at the borderline;
- SSB field strength values in $\text{dB}\mu\text{V}/\text{m}/(30 \text{ kHz})$ using SSB vertical antenna pattern/gain. Two types of SSB antenna patterns are considered, single beam and multi-beam depending on equipment implementations. These SSB implementation specificities need to be taken into account in the determination of SSB field strength values, with multi-beam implying a higher antenna gain for the SSB.

For non-AAS BS, the fixed antenna vertical pattern/gain and tilt is used for both data and control channels and therefore the same field strength values in $\text{dB}\mu\text{V}/\text{m}/(5 \text{ MHz})$ apply to both channel types.

All field strength values are obtained at 3 m height.

The simulated or calculated field strength values for the five cross-border operation modes are summarised in section 4.2. Those field strength values will be the basis for further consideration in the revision of the ECC Recommendation (15)01.

Where DSB is implemented, the field strength values for synchronised operation are applicable at the border.

The DSB implementation zone is determined using an agreed field strength value from section 4.2, noting that different field strength values result in different UL throughput losses.

TABLE OF CONTENTS

0 Executive summary 2

1 Introduction 8

1.1 ECC Recommendations (15)01 and 20(03) and ECC Report 296..... 8

1.2 Background information on field strength values for TDD MFCN unsynchronised operation in ECC Recommendation (15)01 8

1.3 Objective of the Report 8

2 Possible modes of operation for TDD MFCN systems in cross-border areas 10

2.1 Synchronised operation 10

2.2 Unsynchronised operation with partial duplex misalignment and ECC RECOMMENDATION (20)03 recommended scenario without DSB 11

2.3 Unsynchronised operation with partial duplex misalignment and ECC RECOMMENDATION (20)03 recommended scenario with downlink symbol blanking (DSB)..... 11

2.4 Fully-Unsynchronised operation with non-preferential frequency blocks 12

2.5 Unsynchronised operation with preferential frequency blocks 13

3 Interference mitigation solutions 14

3.1 Downlink symbol blanking (DSB) 14

3.1.1 Definition 14

3.1.2 The downlink symbol blanking (DSB) implementation zone..... 15

3.1.3 Performance impacts 16

3.1.3.1 DSB impact on capacity 16

3.1.3.2 DSB impact on coverage..... 16

3.1.4 Implementation aspects and interoperability 17

3.1.4.1 Applicability of DSB to LTE-TDD base stations in the field 17

3.1.5 DSB for the frames recommended in ECC Recommendation (20)03 17

3.1.5.1 DSB impact on capacity for the frames recommended in ECC Recommendation (20)03 17

3.1.5.2 DSB impact on control channels - analysis based on 3GPP specifications for the frames recommended in ECC Recommendation (20)03 19

3.1.5.3 DSB implementation zone for the frames recommended in Recommendation (20)03 23

3.2 Sub-band blanking (SBB) 24

3.2.1 Definition 24

3.2.2 The SB blanking implementation zone 25

3.2.3 Implementation aspects and interoperability 27

3.2.4 Sub-band blanking in a multi operator scenario 27

3.2.5 Sub-band blanking for the frames recommended in the ECC Recommendation (20)03 . 28

3.2.5.1 Sub-band blanking impact on capacity..... 28

4 Analysis of field strength values for TDD MFCN network deployment in border areas..... 34

4.1 Methodology to derive the field strength values 34

4.2 Summary of simulation results and field strength values 36

5 Conclusions..... 39

ANNEX 1: MFCN TECHNICAL PARAMETERS AND ASSUMPTIONS FOR SIMULATIONS 42

A1.1 Simulation assumptions..... 42

A1.2 Simulation scenarios and methodology..... 44

A1.2.1 Synchronised operation 45

A1.2.2 Unsynchronised operation with non-preferential frequency blocks 45

A1.2.3 Unsynchronised operation with preferential frequency blocks 45

A1.2.4 Unsynchronised operation with non-preferential frequency blocks and partial duplex misalignment, using the ECC Recommendation (20)03 [2] recommended scenario..... 46

ANNEX 2: SIMULATION RESULTS FOR SEPARATION DISTANCES vs TP LOSS.....	47
A2.1 Introduction	47
A2.2 Simulation results	48
ANNEX 3: FIELD STRENGTH VALUES	55
ANNEX 4: EXAMPLE OF A CONVERSION FORMULA FROM SSB POWER LEVEL TO THE MAXIMUM DATA FIELD STRENGTH.....	60
A4.1 Methodology to convert SSB measurements into data field strength value.....	61
A4.2 Conclusion	63
ANNEX 5: CROSS-BORDER FIELD TEST RESULTS.....	65
A5.1 Introduction	65
A5.2 Field test description.....	65
A5.3 Field test results	66
ANNEX 6: LIST OF REFERENCES	68

LIST OF ABBREVIATIONS

Abbreviation	Explanation
3GPP	3 rd Generation Partnership Project
5G NR	5G-New Radio
AAS	Active Antenna System
BS	Base Station
BW	Bandwidth
CEPT	European Conference of Postal and Telecommunications Administrations
CRS	Cell-specific Reference Signal
CSI-RS	Channel Status Information Reference Signal
DL	Downlink
DSB	Downlink Symbol Blanking
ECC	Electronic Communications Committee
e.i.r.p.	Effective (Equivalent) Isotropic Radiated Power
FS	Field Strength
FWA	Fixed Wireless Access
HARQ	Hybrid Automatic Repeat Request
LTE-TDD	Long Term Evolution Time Division Duplex
MCL	Minimum Coupling Loss
MFCN	Mobile/Fixed Communication Networks
MIMO	Multiple-Input Multiple-Output
MNO	Mobile Network Operator
MS	Mobile Station
non-AAS	Non-Active Antenna System
NR	Noise Rise
OSI	Other System Information
PCI	Physical-layer Cell Identity
PDCCH	Physical Downlink Control Channel
PRACH	Physical Random Access Channel
RB	Resource Block
REC	Recommendation
RLC	Radio Link Control
RMSI	Remaining Minimum System Information
RSRP	Reference Signal Received Power
SB	Sub-band
SEAMCAT	Spectrum Engineering Advanced Monte Carlo Analysis Tool

SIB	System Information Block
SINR	Signal to Interference plus Noise Ratio
SR	Scheduling Request
SRS	Sounding Reference Signal
SS/PBCH	Synchronisation Signals and Physical Broadcast Channel
SSB	Synchronisation Signal Block
SS-RSRP	Synchronisation Signal Reference Signal Received Power
SSS	Secondary Synchronisation Signal
TDD	Time Division Duplex
UE	User Equipment
UL	Uplink

1 INTRODUCTION

1.1 ECC RECOMMENDATIONS (15)01 AND 20(03) AND ECC REPORT 296

The 3400-3800 MHz frequency band has been identified as one of the pioneer bands for the introduction of 5G networks.

The ECC Recommendation (15)01 [1] as amended on 14 February 2020, addresses, among other bands, the cross-border coordination of TDD MFCN in the frequency band 3400-3800 MHz and provides field strength trigger values for the deployment of networks in border areas.

As mentioned in ECC Recommendation (20)03, "The synchronisation of TDD networks in border areas in this frequency band is recommended as it ensures a higher degree of efficient spectrum utilisation especially for outdoor network deployments. In addition, cross-border synchronisation requires a common phase clock reference and a compatible frame structure to be used on both side of the border to avoid simultaneous UL/DL transmissions" [2].

As mentioned in ECC Report 296, "The chosen frame structure will contribute to the network performance (e.g. latency, spectral efficiency, throughput and coverage)" [4]. Besides, in the context of network deployment in 3400-3800 MHz band in Europe, the situation is complex, some CEPT countries have 5G NR network deployments only, while some other countries have mixed applications e.g. for taking into account legacy networks (although a national migration roadmap of all legacy systems should be defined), indoor TDD MFCN and new services. Therefore the choice of compatible frame structures between neighbouring countries is not always straightforward. Using different frame structures makes the coordination in cross-border area more difficult to manage and it needs an update of the actual ECC Recommendation (15)01.

The ECC Recommendation (20)03 identifies two frame structures for the rollout of TDD networks ("Frame A" and "Frame B") in border areas. It also provides other technical parameters such as the time base and special slot S configuration.

1.2 BACKGROUND INFORMATION ON FIELD STRENGTH VALUES FOR TDD MFCN UNSYNCHRONISED OPERATION IN ECC RECOMMENDATION (15)01

The previous field strength value for unsynchronised TDD in ERC Recommendation (01)01 [5] was 15 dB μ V/m/(5 MHz) at 3 m. Then based on simulations for UMTS-TDD unsynchronised operation in 2 GHz band (1900-1920 MHz), a field strength value of 30 dB μ V/m/(5 MHz) at 3 m was adopted for those systems in 2 GHz band (ERC Recommendation (01)01) and 2.6 GHz band (ECC Recommendation (11)05 [6]). This value was chosen with the assumption of uplink throughput loss of 50% and shared exclusion area at the borderline (noting that the alternative of considering preferential frequency blocks would also lead to a 50% UL and DL capacity loss). Then the field strength value of 32 dB μ V/m/(5 MHz) at 3 m was used for non-AAS TDD wideband systems operating in 3.4-3.8 GHz band when ECC Recommendation (15)01 was developed in 2015 by adding 2 dB frequency scaling factor from 2.6 GHz to 3.6 GHz band. Therefore such a value of 32 dB μ V/m at 3 m assumes that there is no victim located at borderline.

In the revision of ECC Recommendation (15)01 in 2019, simulations for both non-AAS and AAS wideband systems (LTE and 5G NR) were performed, the field strength value of 0 dB μ V/m/(5 MHz) at 3 m was obtained based on an uplink throughput loss between 5 % and 10%. This field strength value of 0 dB μ V/m/(5 MHz) at 3 m can lead in practice to very large exclusion zones in cross-border areas. In order to facilitate the deployment of TDD MFCN in border areas, there is a need to study the field strength values with different more realistic deployment options and to analyse operational solutions for efficient usage of spectrum.

1.3 OBJECTIVE OF THE REPORT

The objectives of this Report are:

- 1 Further investigate the field strength values with respect to the ECC Recommendation (15)01 for AAS BS and non-AAS BS with more realistic operational network deployment scenarios and assumptions for different modes of operation in cross-border areas;
- 2 Describe and analyse interference mitigation solutions, such as downlink symbol blanking and sub-band blanking.

2 POSSIBLE MODES OF OPERATION FOR TDD MFCN SYSTEMS IN CROSS-BORDER AREAS

This section provides the technical information which needs to be agreed between administrations/operators in border areas for various operating modes which can be implemented.

2.1 SYNCHRONISED OPERATION

In TDD networks, synchronised operation means that in an environment with several different networks, there is no simultaneous UL/DL transmission. Synchronised operation avoids the need for any separation distances at the border (both for AAS and non-AAS BS) and enables an efficient use of the spectrum but requires all operators to agree on the common phase clock reference and on compatible frame structures.

More detailed description about the definition of synchronised operation can be found in ECC Report 216 [3] and ECC Report 296 [4].

In order to deploy synchronised TDD mobile networks in border areas, administrations/operators need to reach agreement on the following:

- A common phase clock reference (e.g. UTC, Coordinated Universal Time) with an accuracy of +/-1.5 μ s;
- Configuring compatible frame structures, i.e. setting the length of the frame, the TDD uplink/downlink ratio and guard period in order to align UL/DL switching points, so that the last transmission from BSs on one side of the border stops before the start of BSs reception on the other side, taking into account the propagation delay (e.g. in line-of-sight non co-sited cases). Frame structures do not need to be exactly identical provided this condition is met, which enables different sizes for the guard period.

As shown in Figure 1, for synchronised operation the field strength value is determined based on an acceptable DL throughput loss below 5%. In order to protect MSs camped on the network at the other side of the border, preferential PCIs are recommended. Operators may deploy their networks following the field strength values defined for synchronised operations.

Synchronised BSs may be deployed closer to the border (i.e. beyond the separation distance shown in the figure), while still respecting the field strength trigger value, with careful planning (e.g. the antennas may need to be oriented away from the border line or with appropriate downtilt).

- Field strength trigger value for synchronized operation
- 📶 Synchronized BSs deployed based on the field strength trigger values to be met at the border line for synchronized operation

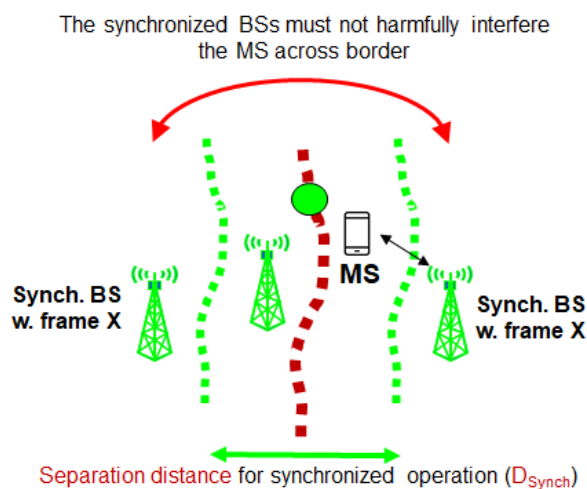

NOTE: all BSs adopt a common phase clock reference and a compatible frame structure

Figure 1: Separation distance and field strength trigger values for synchronised operation

2.2 UNSYNCHRONISED OPERATION WITH PARTIAL DUPLEX MISALIGNMENT AND ECC RECOMMENDATION (20)03 RECOMMENDED SCENARIO WITHOUT DSB

The ECC Recommendation (20)03 [2] recommends the use of two frame structures in the 3400-3800 MHz frequency band, "Frame A" and "Frame B", as defined in annex 1 of ECC Recommendation (20)03) especially for outdoor TDD MFCN with an agreed common phase clock reference in order to facilitate cross-border coordination, and as illustrated in Figure 2.

	Slot numbers in the NR half Frame									
	0	1	2	3	4	5	6	7	8	9
Frame A DDDSU	D	D	D	S	U	D	D	D	S	U
Frame B DDDSUDDDD	D	D	D	S	U	U	D	D	D	D

Figure 2: Frame structures recommended in the ECC Recommendation (20)03

Note: In terms of DL/UL slot pattern DDDSUDDDD half-frame B is equivalent to the DDDDDDDSUU half-frame when a -2 ms or +3 ms time offset is applied. This means that, instead of frame B, operators may choose to implement two consecutive DDDDDDDSUU half-frames with proper time offset. More generally, there should be a common understanding about the definition of "start-of-frame": Some technologies define it as the start-of-downlink while some other technologies define it with respect to the position of some signalling symbols which do not always correspond to the start-of-downlink (see note 3 within annex 1 table 1 in ECC Recommendation (20)03)).

For this mode of operation in border areas, administrations/operators need to reach agreement on the following:

- A common phase clock reference (e.g. UTC, Coordinated Universal Time) with an accuracy of +/-1.5 μ s (to reduce the interference in border areas, to some extent);
- A frame structure "Frame A" or "Frame B" (as defined in annex 1 of ECC Recommendation (20)03) depending on their national requirements (e.g. compatibility with LTE-TDD networks)).

This recommended scenario leads to a theoretical DL to UL slot collision probability of 50%⁴ (see section A1.2.4) in the border areas when operators in one country use "Frame A" while "Frame B" is used by operators in the other country.

Synchronised operation is achieved when operators of neighbouring countries use the same frame (either "Frame A" or "Frame B"), with a common phase clock reference.

2.3 UNSYNCHRONISED OPERATION WITH PARTIAL DUPLEX MISALIGNMENT AND ECC RECOMMENDATION (20)03 RECOMMENDED SCENARIO WITH DOWNLINK SYMBOL BLANKING (DSB)

When operators in one country use "Frame A" while "Frame B" is used by operators in the other country, the downlink symbol blanking feature can be introduced in border areas (as defined and described in section 3.1). This operating mode ensures coexistence between networks using "Frame A" and "Frame B" in border areas without cross-link interference (similar to the synchronised operation) with a certain downlink capacity loss (see section 3.1.5.1).

This mode of operation in border areas requires administrations/operators from neighbouring countries to agree on:

- A common phase clock reference (e.g. UTC, Coordinated Universal Time) with an accuracy of +/-1.5 μ s;

⁴ A field test as described in Annex 5 indicates that the corresponding UL throughput loss can be higher than 50%, in some cases, and that DL throughput loss can also be significant

- A frame structure “Frame A” or “Frame B” (as defined in annex 1 of ECC Recommendation (20)03)⁵;
- Blanking downlink symbols of each network that correspond to simultaneous uplink transmissions or simultaneous gap symbols for the other network (gap symbols in the “S” slots at the transition from a downlink slot to an uplink slot) in order to avoid simultaneous UL/DL transmissions;
- The geographical area near the border where the downlink symbol blanking needs to be implemented (“DSB implementation zone” hereafter).

2.4 FULLY-UNSYNCHRONISED OPERATION WITH NON-PREFERENTIAL FREQUENCY BLOCKS

The unsynchronised operation refers to the case where there is no agreement between administrations/operators of neighbouring countries for the implementation of a common phase clock reference or a compatible frame structure.

In case of unsynchronised operation with non-preferential frequency blocks, operators may use any portion of assigned spectrum and co-channel operation between operators in neighbouring countries cannot be avoided.

In this case, the field strength value is determined based on the separation distance (see Figure 3) required to avoid harmful co-channel interference to the uplink belonging to BSs deployed on the other side of the border. Large separation distances are required to reduce the co-channel interference below an acceptable UL throughput loss.

Operators may deploy their networks following the field strength values defined in section 4 for unsynchronised operation with non-preferential frequency blocks. The field strength values for this mode of operation are derived assuming the worst-case of two adjacent operators with misaligned duplex directions for the whole frame duration which in this Report is referred to as “fully-unsynchronised”.

- Field strength trigger value for unsynchronized operation
- 📶 Unsynchronized BSs deployed based on the field strength trigger values to be met at the border line for unsynchronized operation

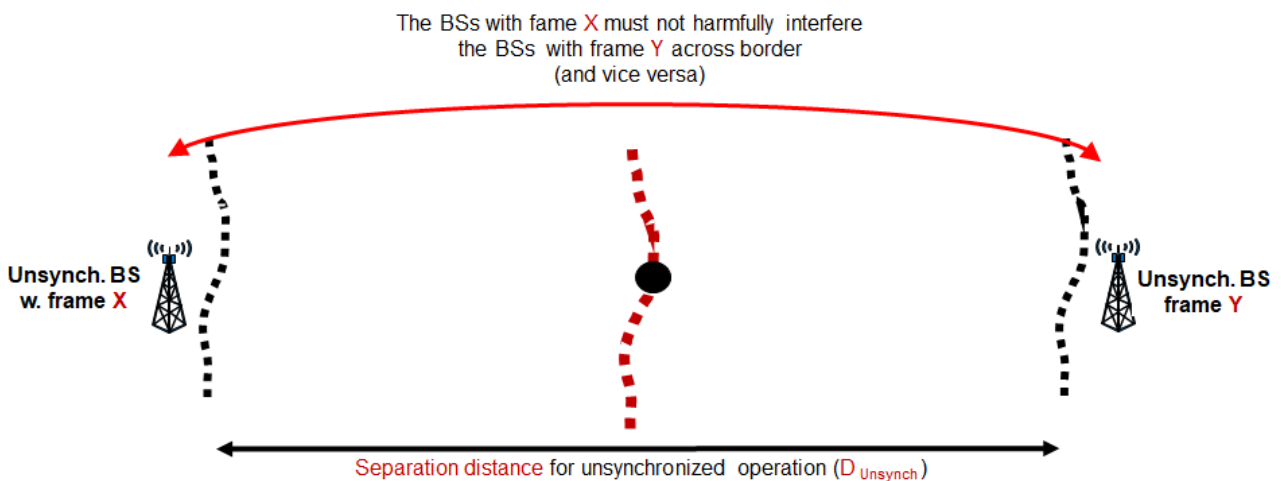

NOTE: all BSs do not adopt a common phase clock reference and/or compatible frame structures

Figure 3: Separation distance and field strength trigger values for unsynchronised operation

⁵ Limiting options to those two frame structures as defined in ECC Recommendation (20)03 would avoid combinatorial complexity and enable equipment vendors to have economies of scale when implementing DSB.

2.5 UNSYNCHRONISED OPERATION WITH PREFERENTIAL FREQUENCY BLOCKS

In case of fully-unsynchronised operation with preferential frequency blocks, administrations/operators may conclude bi/multilateral agreements/arrangements to define preferential frequency blocks. The radio spectrum is therefore divided between countries/operators in order to avoid co-channel interference in border areas, but adjacent channel interference still exists.

In this case, the field strength trigger value is determined based on the separation distance (see Figure 3) to keep the adjacent channel interference below an acceptable UL throughput loss.

In the context where 5G NR networks benefit from wide contiguous spectrum blocks, unsynchronised operation with preferential frequency blocks is not foreseen to be implemented in border areas between neighbouring countries. In addition to that, this mode of operation does not allow efficient use of the spectrum.

3 INTERFERENCE MITIGATION SOLUTIONS

This section describes two interference mitigation solutions which are options to facilitate cross-border coordination. Implementation and interoperability aspects for these options are assessed. The implementation zones are determined based on field strength values at the border.

3.1 DOWNLINK SYMBOL BLANKING (DSB)

3.1.1 Definition

The downlink symbol blanking (DSB) feature can be used to facilitate cross-border coordination between operators who decide to use two non-compatible frame structures while adopting a common phase clock reference.

When operators in one country use “Frame A” while “Frame B” is used by operators in the other country while adopting a common phase clock reference⁶, the downlink symbol blanking (DSB) feature can be used to facilitate cross-border coordination between operators.

DSB allows the base stations’ schedulers to switch off transmissions (“blanking”) for those downlink symbols (“blanked DL symbols”) of each network that correspond to simultaneous uplink reception or simultaneous gap symbols⁷ for the other network.

By avoiding simultaneous DL/UL transmissions in the geographical “DSB implementation zone” near the borders, DSB allows the deployment of non-compatible frame structures across borders, benefiting from the advantages of coordination in case of synchronised operation with some degree of downlink capacity loss and some loss in coverage, depending on the implementation.

This can avoid geographical isolation between two networks due to the fact that DL transmissions will not collide with UL reception from the other network. The operators will be able to use their preferred frame structure (without the need to apply blanking) outside the geographical “DSB implementation zone”. DSB could be complemented by one or more interference reduction mechanisms such as antenna tilting, restricted beamforming, downlink power reduction, or minimum inter-cell interference scheduling. Such mechanisms could reduce the geographical “DSB implementation zone”.

⁶ The DL symbols blanking approach was first included in the revised ECC Recommendation (15)01 (latest amendment on 14 February 2020). [1]

⁷ Either uplink symbols in uplink slots or uplink and gap symbols in the “S” slots at the transition from a downlink slot to an uplink slot.

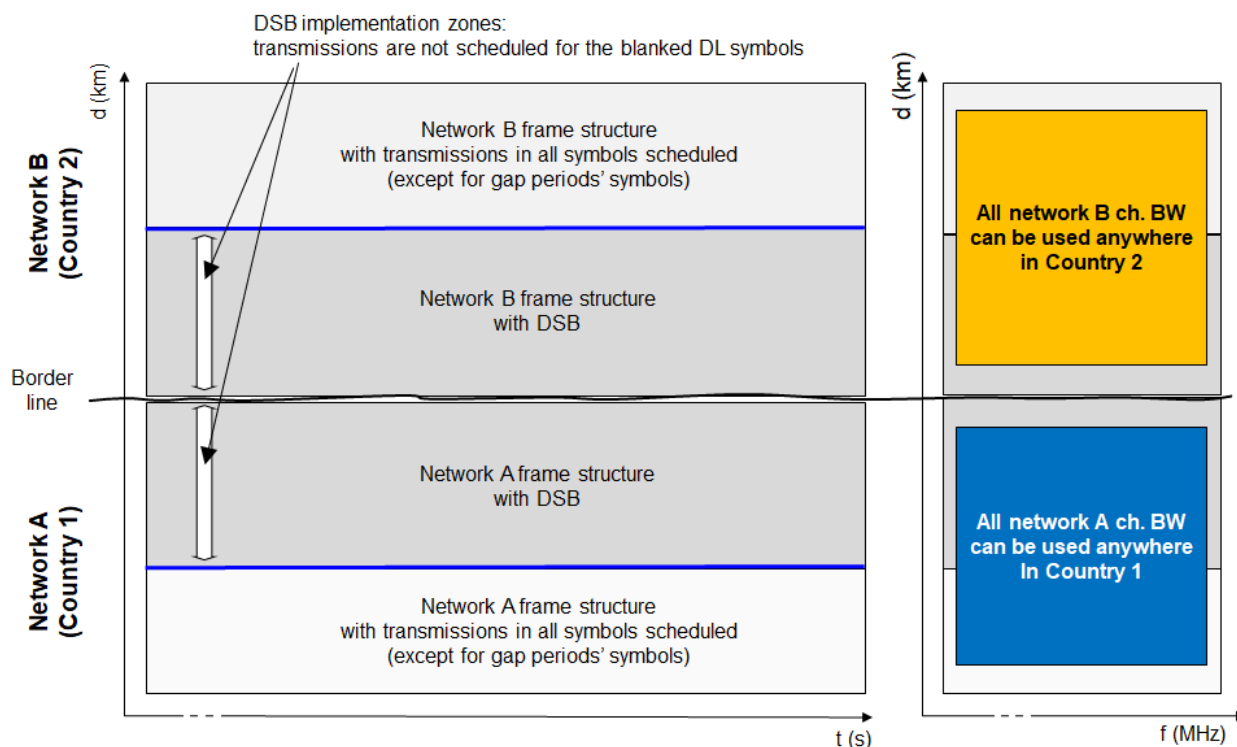

Figure 4: The downlink symbol blanking concept

The adoption of this technique requires agreement between all stakeholders involved in bilateral/multilateral cross-border discussions. More precisely, the involved parties will need to agree on:

- A common phase clock reference (e.g. UTC, Coordinated Universal Time) with an accuracy of $\pm 1.5 \mu\text{s}$;
- Frame time shift allowing to maximise the frame alignment over the air, this means that involved parties need to use the correct offset in order to obtain the best alignment between the frames;
- Sharing information of the frame structure used and agree to perform blanking of downlink symbols of each network that correspond to simultaneous uplink transmissions or simultaneous gap symbols for the other network (either symbols in uplink slots or uplink and gap symbols in the NR “S” slots at the transition from a downlink slot to an uplink slot) in order to have a fair treatment between neighbouring networks;
- The identification of the geographical DSB implementation zone for application of downlink symbol blanking on each side of the border. The size of the geographical DSB implementation zone is determined by the separation distances for synchronised and unsynchronised operation as described in section 3.1.2. Base stations deployed within this geographical DSB implementation zone from the border will apply downlink symbol blanking and may suffer from downlink throughput performance degradation (see section 3.1.3).

Being based on the time domain, while the illustrative example refers to fully overlapped frequency channels, this approach equally applies to the case of non-overlapping frequency blocks assignments across borders.

3.1.2 The downlink symbol blanking (DSB) implementation zone

When DSB is applied, i.e. when operators across borders use non-compatible frame structures while adopting a common phase clock reference and use the DSB feature, the size of the area where blanked base stations will need to be deployed (the DSB implementation zone) is determined by the need for the BSs operating without DSB in one network to avoid causing unacceptable interference to the uplink of networks in the DSB implementation zone of the other country. The field strength levels determining the DSB implementation zone can therefore be derived from the separation distance for unsynchronised operation.

The BS implementing DSB can be deployed based on the field strength trigger values to be met at the border line for synchronised operation.

The DSB implementation zone is illustrated in Figure 5 for the generic frames frame X and frame Y: DSB is to be implemented in a geographical area from the borderline, on each side, to minimise the uplink throughput loss (below an acceptable level to be agreed) caused by the interference from BSs beyond the DSB implementation zone of the network from the opposite side.

BS implementing and activating DSB may be deployed in identical conditions as synchronised operation.

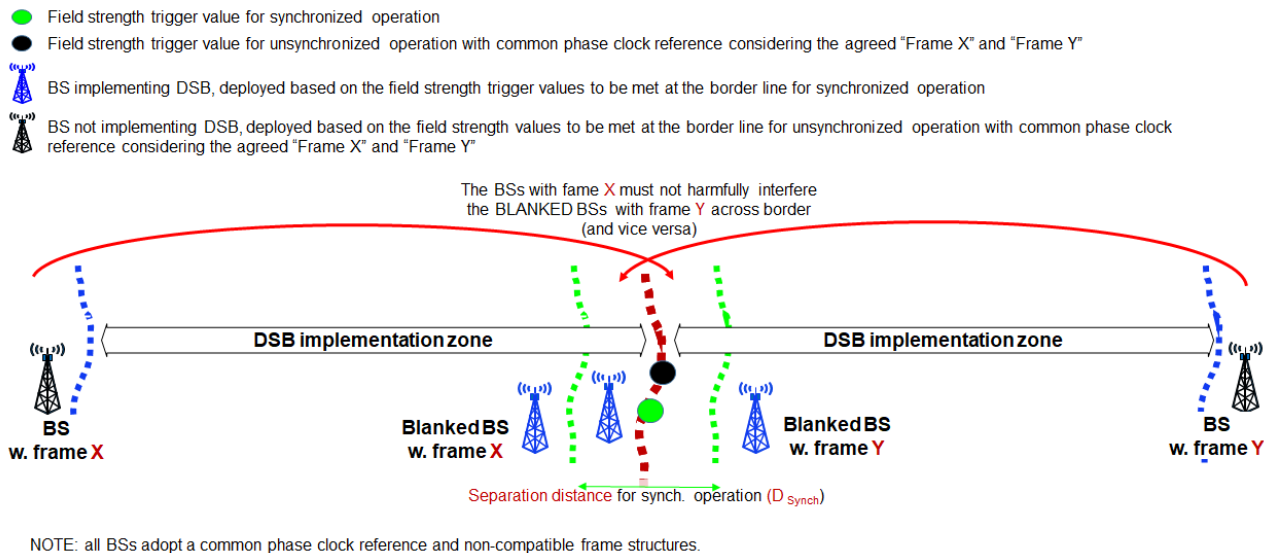

Figure 5: The DSB implementation zone

The DSB implementation zone is further analysed in the case of adoption of the "Frame A" and "Frame B" recommended in ECC Recommendation (20)03 in section 3.1.5.

3.1.3 Performance impacts

3.1.3.1 DSB impact on capacity

The adoption of DSB will lead to a reduction in the availability of DL symbols inside the geographical "DSB implementation zone" due to the fact that there are no DL transmissions in some symbols to avoid interference towards the uplink of the neighbouring network.

Table 9 in ECC Recommendation (20)03 [2] provides a summary of the different examples of downlink symbol loss inside the geographical "DSB implementation zone" due to DSB and adds the following remark: "No more than two NR frame structures should be used in order to reduce the capacity loss at the border".

3.1.3.2 DSB impact on coverage

Some coverage loss will be experienced where DSB is applied due to the possible blanking of SS⁸/PBCH⁹ blocks (SSBs), depending on the implementation. Moreover, the expected impact depends on the specific frame structures (see section 3.1.5.2). Specific features (e.g. power boosting for SSBs at the expense of some additional DL capacity loss) could be considered to mitigate this.

⁸ SS: Synchronisation Signal

⁹ PBCH: Physical Broadcast CHannel

3.1.4 Implementation aspects and interoperability

DSB is a base station scheduler feature applied to base stations in the geographical “DSB implementation zone”, is product-implementation dependent and does not require standardisation by 3GPP.

The scheduler of the operators’ base stations that are located within the geographical “DSB implementation zone” will be configured to implement the required DSB. Transmission in all DL symbols will be scheduled for the BS outside of the geographical “DSB implementation zone”.

As DSB does not trigger any specific signalling to the UE, there is no hardware impact and no software impact on UEs.

The feature of DSB is implemented by different vendors on the assumption of a common phase clock reference with sufficient accuracy using the TDD frame structures that are recommended in ECC Recommendation (20)03 [2]. At the time of this writing, it is anticipated that there shouldn’t be any interoperability problem between different vendors when DSB is implemented in the ECC Recommendation (20)03 recommended scenario¹⁰.

At the time of writing this Report, considering the benefits in facilitating cross-border coordination, DSB feature is being implemented based on ECC Recommendation (20)03, according to market demand.

3.1.4.1 *Applicability of DSB to LTE-TDD base stations in the field*

The availability of DSB applied to LTE-TDD base stations requires a clear market demand which may be a challenge due to the limited size of the market and the general trend to 5G.

Besides, if DSB is applied in case of LTE-TDD networks, the channel estimation in LTE TDD will be degraded to some extent, due to the fact that only part of the CRS (Cell-specific Reference Signal) will be transmitted, leading to less accurate RSRP and SINR measurement at the MS side. This impact has not been quantified.

3.1.5 DSB for the frames recommended in ECC Recommendation (20)03

CEPT has recently issued ECC Recommendation (20)03 [2] regarding TDD MFCN frame structures to be used in cross-border coordination in order to facilitate the negotiation of bilateral/multilateral agreements between administrations and facilitate operator arrangements, as well as the development of DSB feature in due time.

The CEPT administrations are encouraged to use the frame structures A and B as defined in ECC Recommendation (20)03¹¹ for TDD networks in the frequency band 3400-3800 MHz in order to facilitate cross-border coordination and facilitate the development of DSB feature in due time, as well as the negotiation of cross-border coordination agreements between administrations.

3.1.5.1 *DSB impact on capacity for the frames recommended in ECC Recommendation (20)03*

The following figures illustrate the specific application of the DSB feature in case of simultaneous use of the above frame structures across borders.

¹⁰ Interoperability between vendors should be verified in practice

¹¹ See Annex 1 in ECC Recommendation (20)03 for a more accurate description.

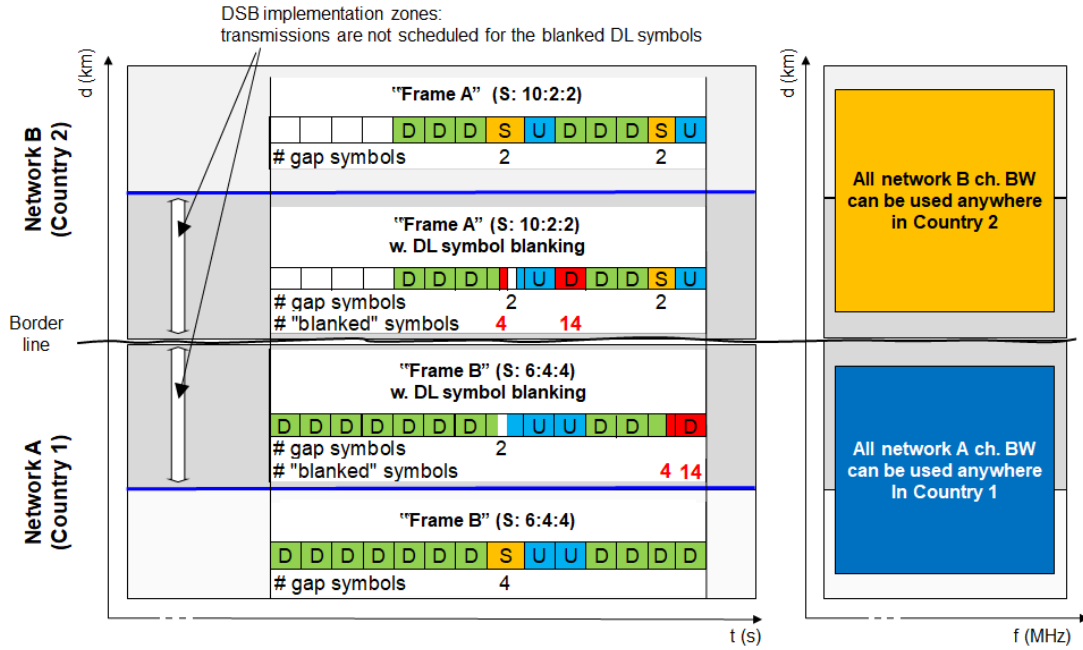

Figure 6: Application of DSB to "Frame A" and "Frame B" recommended by ECC Recommendation (20)03 [2]

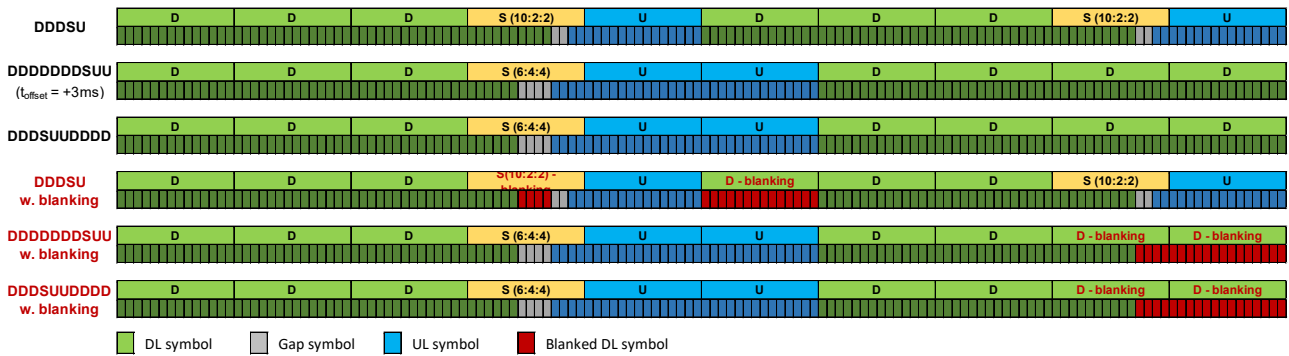

Figure 7: Application of DSB to "Frame A" and "Frame B" recommended by ECC Recommendation (20)03 – symbol level view

For the sake of clarity, Figure 7 provides a detailed view on how DSB is applied to "S (10:2:2)" in the DDDDSU frame overlapping with the "S (6:4:4)" slot in the DDDDDDDSUU frame.

Blanking of some selected DL symbols leads to the following downlink symbol loss:

- 17.3% DL capacity loss in the country where frame A is used;
- 17.3% DL capacity loss in the country where frame B is used;

Downlink Symbol Blanking is expected to fully switch off transmissions (i.e. both traffic and control channels) during a blanked time period.

Table 1: Examples of downlink symbol loss in a single frame (10 ms) due to DSB

Frame structures (30 kHz SCS)	DL	Blanked	GAP	UL	TOTAL
Frame A i.e. DDDDSU (S=10:2:2)	No blanking	208	0	8	280
	w. blanking	172	36	8	280
	Delta	-17.3%			

Frame structures (30 kHz SCS)		DL	Blanked	GAP	UL	TOTAL
Frame B i.e. DDDDDDDSUU (+3/-2ms offset) or DDDSUUUUUU (S=6:4:4)	No blanking	208	0	8	64	280
	w. blanking	172	36	8	64	280
	Delta	-17.3%				

3.1.5.2 DSB impact on control channels - analysis based on 3GPP specifications for the frames recommended in ECC Recommendation (20)03

The following analysis is based on 3GPP specifications¹².

Several NR control channels have a fixed or semi-fixed position in the frame pre-defined by 3GPP. Therefore, the actual frame structure may forbid to transmit some of this control channels.

Typically, the maximum number of SS/PBCH blocks (SSBs) depends on the frequency range and their positions are fixed depending on the SCS. Moreover, the SIB1¹³/RMSI¹⁴ associated with each SS/PBCH block also has a predefined position which may conflict with the actual frame structure. A SS/PBCH block is pointless if it is not followed by a SIB1/RMSI. Other control channels (OSI and paging) are not impacted by SIB1/RMSI.

The analysis accounts for the following assumptions based on 3GPP 5G NR specifications guidance [7], applied to the case of below 6 GHz frequency range, SCS 30 kHz, "Case C" mapping pattern.

Considering that 5G NR extends coverage for all control channels with beamforming, a large number of SSBs (SS/PBCH blocks) is recommended especially for 3D beamforming (some SSBs are used for the vertical direction). According to 3GPP, the maximum number of SS/PBCH blocks is 8 and their time position inside the frame is fixed. In particular, the SSBs are periodically transmitted in the first 2 ms of one SSB period of minimum 5 ms, i.e., SSB beams are transmitted in the first 4 slot in each half frame. Furthermore, each SSB requires a minimum of 4 consecutive DL-symbols to be allowed. In case of a DDDSU frame structure, 7 SSBs are allowed. Finally, one full DL slot can contain the SIB1 (System Information Block)/RMSI (Remaining Minimum System Information) of only 1 SSB and a slot with less than 6 DL symbols cannot carry a SIB1/RMSI.

The following figures summarise the available SSBs after accounting for the assumptions above, i.e. the impact of:

- the frame structure on the SSB;
- the frame structure on the SIB1 associated to the SSB;
- DSB.

With reference to CSI-RS (Channel State Information) Reference Signal: periodicity and offset of CSI-RS can be configured by higher layers. No impacts are therefore foreseen.

¹² Product implementation may consider additional constraints

¹³ SIB: System Information Block

¹⁴ RMSI: Remaining Minimum System Information

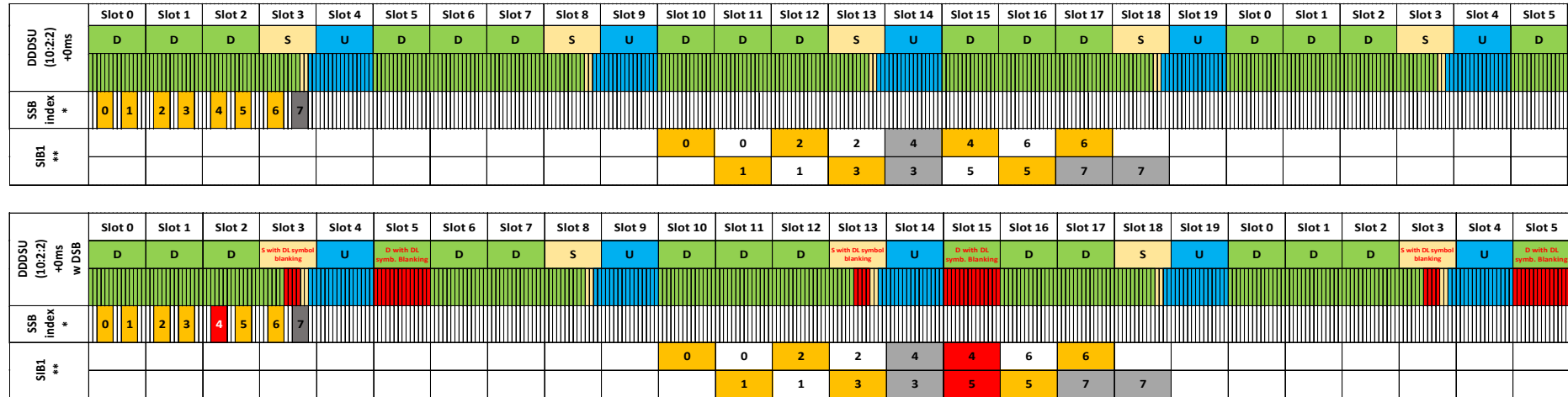

[7]

** Possible SIB1 positions for each SSB (assuming index=4 in ETSI TS 38.213 table 13-11)

DL symbol loss (36 symbols)	17%
# SSB possible	8
# SSB lost due to frame	1
# SIB1 lost due to frame	1
# SSB w/o blanking allowed by frame	7
# SSB lost due to blanking	0
# SIB1 lost due to blanking	1
Resulting # SSB w blanking	6

LEGEND

SSB index	X	Index X SSB used
SSB index	X	Index X SSB forbidden because of frame structure
SSB index	X	Index X SSB forbidden because of BLANKING
SIB1/RMSI	SSBx	Slot allowed for SIB1 associated with SSBx
SIB1/RMSI	SSBx	Slot used for SIB1 associated with SSBx
SIB1/RMSI	SSBx	Slot unused for SIB1 because of frame structure
SIB1/RMSI	SSBx	Slot forbidden for SIB1 of SSBx because of BLANKING

Figure 8: Impact on SSBs transmissions for 4 x DDSU (S=10:2:2) + 0 ms

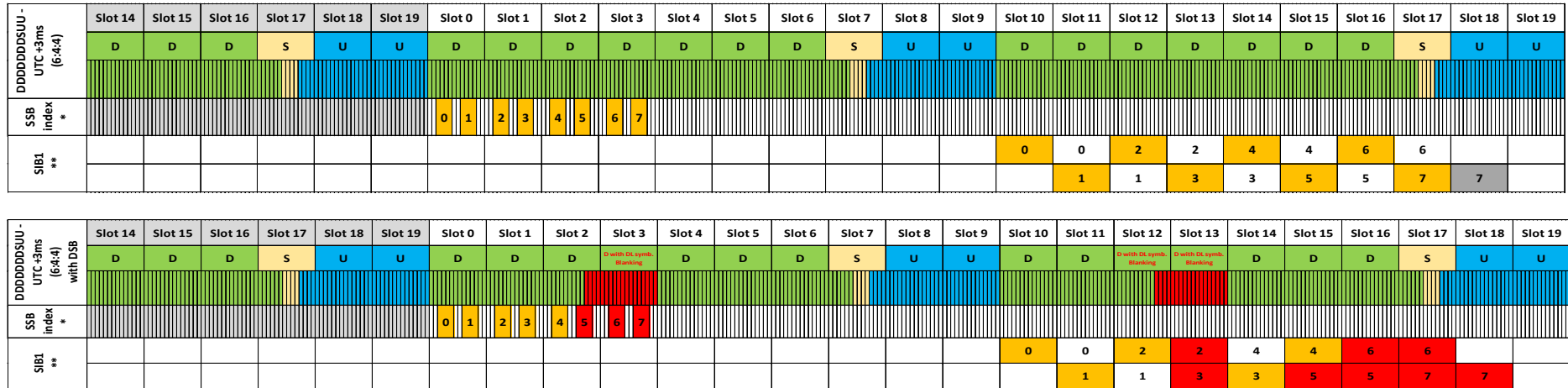

* SSB positions (ETSI TS 38.213 section 4 [7])

** Possible SIB1 positions for each SSB (assuming index=4 in ETSI TS 38.213 table 13-11)

DL symbol loss (36 symbols)	17%
# SSB allowed by frame	8
# SSB lost due to frame	0
# SIB1 lost due to frame	0
# SSB w/o blanking allowed by frame	8
# SSB lost due to blanking	3
# SIB1 lost due to blanking	3
Resulting # SSB w blanking	5

LEGEND

- SSB index X Index X SSB used
- SSB index X Index X SSB forbidden because of frame structure
- SSB index X Index X SSB forbidden because of BLANKING
- SIB1/RMSI SSBx Slot allowed for SIB1 associated with SSBx
- SIB1/RMSI SSBx Slot used for SIB1 associated with SSBx
- SIB1/RMSI SSBx Slot unused for SIB1 because of frame structure
- SIB1/RMSI SSBx Slot forbidden for SIB1 of SSBx because of BLANKING

Figure 9: Impact on SSBs transmissions for 2 x DDDDDDSUU (S=6:4:4) +333 ms

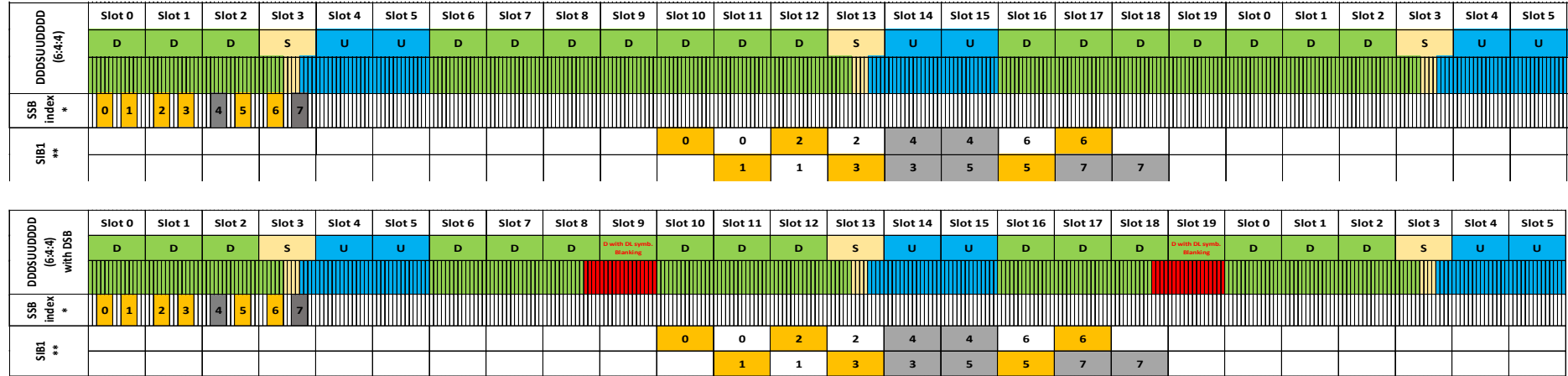

* SSB positions (ETSI TS 38.213 section 4 [7])

** Possible SIB1 positions for each SSB (assuming index=4 in ETSI TS 38.213, table 13-11)

DL symbol loss (36 symbols)	17%
# SSB possible	8
# SSB lost due to frame	2
# SIB1 lost due to frame	2
# SSB w/o blanking allowed by frame	6
# SSB lost due to blanking	0
# SIB1 lost due to blanking	0
Resulting # SSB w blanking	6

LEGEND

SSB index	X	Index X SSB used
SSB index	X	Index X SSB forbidden because of frame structure
SSB index	X	Index X SSB forbidden because of BLANKING
SIB1/RMSI	SSBx	Slot allowed for SIB1 associated with SSBx
SIB1/RMSI	SSBx	Slot used for SIB1 associated with SSBx
SIB1/RMSI	SSBx	Slot unused for SIB1 because of frame structure
SIB1/RMSI	SSBx	Slot forbidden for SIB1 of SSBx because of BLANKING

Figure 10: Impact on SSBs transmissions for 2 x DDSUDDDD (S=6:4:4) +0 ms

Table 2: Summary of impacts from frame structures and DSB on SSBs transmissions

	DDDSUDDDSU DDDSUDDDSU + 0 ms (S=10:2:2)	DDDDDDDSUU DDDDDDDSUU +3/-2 ms (S=6:4:4)	DDDSUDDDDD DDDSUDDDDD +0 ms (S=6:4:4)
DL symbol loss/10 ms	17.3% (36 symbols)	17.3% (36 symbols)	17.3% (36 symbols)
# of SSBs allowed by the frame	7	8	7
# SIB1 lost due to frame	0	0	1
# SSB locations available before blanking	7	8	6
# SSB locations lost due to DSB	0	3	0
# SIB1 lost due to DSB	1	0	0
# SSB locations available w. blanking	6	5	6

No impact on UL coverage is foreseen.

The proposed approach does not lead to impacts on the transmissions of UL.

3.1.5.3 DSB implementation zone for the frames recommended in Recommendation (20)03

The DSB implementation zone was introduced in case of generic frame structures in section 3.1.2.

This section analyses the specific case when DSB is applied to the ECC Recommendation (20)03 [2] recommended scenario where networks adopt the two different frame structures ("Frame A" and "Frame B", together with a common phase clock reference."). In this case, Figure 5 still applies once frame X and frame Y are replaced with "Frame A" and "Frame B" respectively.

As demonstrated in section A1.2.4, when the ECC Recommendation (20)03 recommended scenario is adopted the DL to UL slot collision probability is 50%¹⁵ (because of partial duplex misalignment): the UL throughput loss in a network using "Frame A" caused by co-channel interference from the network using "Frame B" DL in a neighbouring country (and vice versa) is therefore expected to be half of that in a fully unsynchronised case described in section 2.4.

In line with the conclusions from section 3.1.2, the field strength determining the size of the DSB implementation zone is derived from the separation distances computed for the operation mode "Unsynchronised operation with partial duplex misalignment based on the ECC Recommendation (20)03 recommended scenario without DSB". The field strength is computed with the assumption that the victim network can be located at the borderline (while operation mode without DSB is assuming that the separation distance is shared across the two networks at the border). The field strength levels for determining the DSB implementation zone are given in section 4.

¹⁵ A field test as described in Annex 5 indicates that the corresponding UL throughput loss can be higher than 50%, in some cases, and that DL throughput loss can also be significant

3.2 SUB-BAND BLANKING (SBB)

3.2.1 Definition

The sub-band blanking (SBB) feature is considered as a potential alternative interference mitigation solution to facilitate cross-border coordination between two operators who decide to use two non-compatible frame structures while adopting a common phase clock reference. In the context of sub-band blanking, the slots where DL/UL are aligned in both frame structures are referred to as fixed DL and fixed UL slots, respectively. All other slots, where DL and UL are not aligned, are indicated as flexible slots.

For sub-band blanking it is considered to use different duplex directions provided that only a non-overlapping portion of the available carrier bandwidth is used in the flexible slots by two networks as identified in the Figure 11.

The bandwidth of the flexible slot in the baseline frame can be split between a downlink sub-band and an uplink sub-band corresponding to different networks on either side of the border. The operators can then either use the DL portion of the bandwidth for downlink transmission or UL portion of the bandwidth for uplink reception. In other words, the DL and UL portions are not used simultaneously by the same network. Therefore, Network A blanks the sub-band used by Network B and vice versa. As depicted in Figure 11, Network A uses the DL portion and Network B uses the UL portion within the flexible slots.

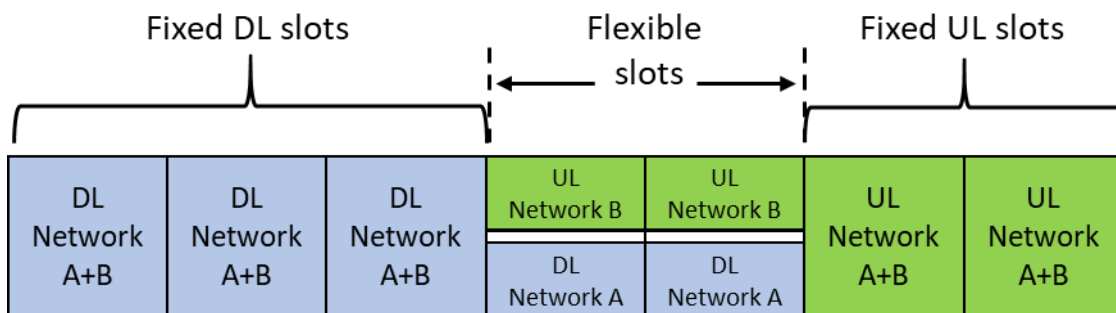

Figure 11: General concept of sub-band blanking

In the context of cross-border coordination, it is assumed that in the flexible slots, DL and UL resources are split between the two operators operating in different countries. Consequently, within the same channel cross-link interference from DL to UL can be perceived across adjacent resources. To mitigate the cross-link interference, it is assumed that some RBs are used as a guard band between UL and DL resources as depicted in Figure 11. The feasibility and effectiveness of such a guard band is assessed in section 3.2.3.

Sub-band blanking also provides flexibility to adapt to the unique conditions experienced at each border situation at the cost of some cross-link interference and DL/UL capacity loss due to blanked radio resources. The UL and DL sub-band allocation can be decided between the border operators jointly, allowing them to balance the impact on DL and UL based on their needs.

The adoption of this technique requires agreement between all administrations/operators involved in bilateral/multilateral cross-border coordination. More precisely, the involved parties will need to agree on:

- A common phase clock reference (e.g., UTC, Coordinated Universal Time) with an accuracy of +/- 1.5 μ s;
- The guard band size between the downlink and uplink portions in the flexible slot to reduce the leakage between the sub-bands;
- The number of blanked RBs in downlink and uplink for each operator;
- Sharing information of the used frame structure with the identification of the slot S;

- Blanking specific number of RBs in downlink and uplink slots of each network that correspond to simultaneous uplink/downlink transmissions or simultaneous gap symbols for the other network (in the slot "S" at the transition from a downlink slot to an uplink slot) in order to reduce the cross-link interference due to simultaneous UL/DL transmissions;
- The identification of the geographical SB blanking implementation zone on each side of the border. Base station in each country deployed within this implementation zone from the border will need to apply SB blanking and will suffer from downlink and uplink throughput performance degradation. The trade-off between downlink and uplink throughput degradation depends on the number of blanked RBs in downlink and uplink for each operator.

The agreement would need to rely on a known leakage level in the in-band adjacent resource blocks which would require further standardisation.

Operations with SB blanking allow coexistence of different frame structures in border areas with lower interference than unsynchronised operation.

3.2.2 The SB blanking implementation zone

This section describes the concept of the sub-band blanking implementation zone. The separation distance in case of unsynchronised operation with a common phase clock reference and non-compatible frame structures with sub-band blanking is depicted in Figure 12. Here, $D_{SB \text{ blanking}}$ is the minimum separation distance required between the BSs across the borders. It is defined as the distance where less than X% UL degradation is observed due to cross-link interference. The sub-band blanking separation distance depends on the leakage levels and adjacent block rejection that can be achieved in the in-band adjacent frequency resources which require further study.

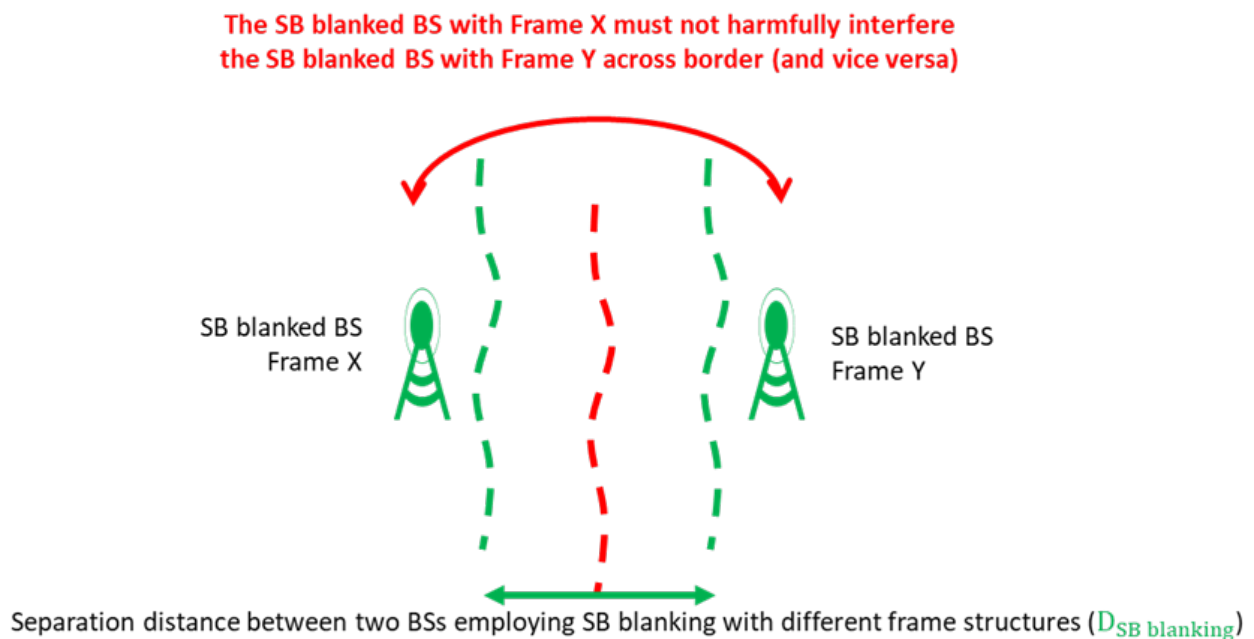
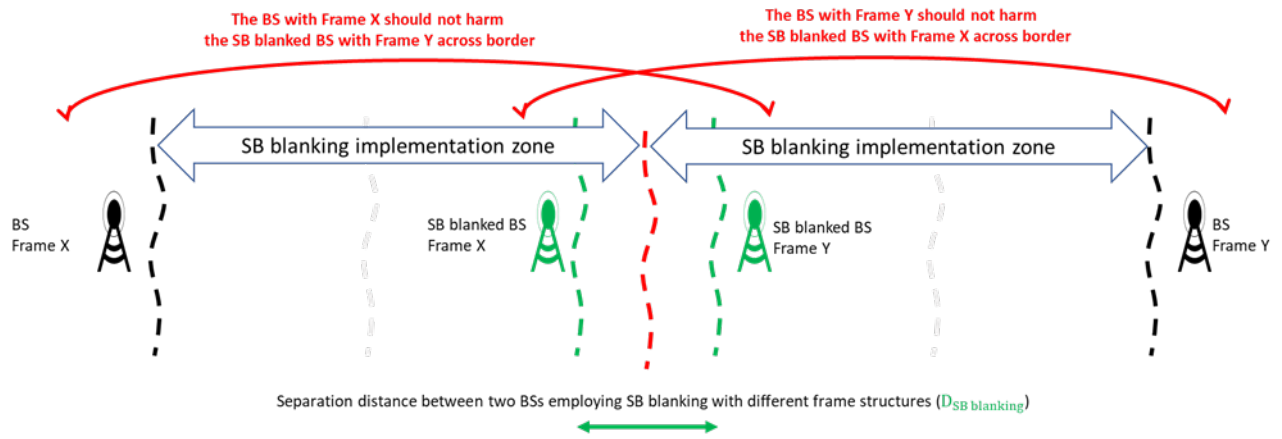

Figure 12 : The separation distance in case of unsynchronised operation with a common phase clock reference with sub-band blanking

The implementation zone of the operation of the sub-band blanking is shown in Figure 13. Here, the unsynchronised BS with a common phase clock reference far away from the border beyond the SB blanking implementation zone should not cause unacceptable interference to the UL of the sub-band blanked BS on the other side of the border. The size of the SB blanking implementation zone is determined using field strength values calculated for unsynchronised operation with a common phase clock reference from the BSs outside SB blanking implementation zone, for an UL and DL throughput loss on the BSs of the victim network near the borderline at an acceptable level which needs to be agreed.



NOTE: all BSs adopt a common phase clock reference and non-compatible frame structures.

Figure 13: The SB blanking implementation zone

The sub-band blanking technique requires agreement between the operators across the border. On the other hand, the sub-band blanking technique does not require nationwide deployment. It is sufficient to implement sub-band blanking only within the sub-band blanking implementation zone from the border. The transition from sub-band blanking to normal operation within one country has no impact on the operation of the network in that country. Figure 14 depicts the scenario for both frame structures with two groups of BSs in the same country. Here, one group of BSs use sub-band blanking, and the other group of BSs use normal operation. Since the frame structures are compatible there is no BS to BS interference between BS implementing SBB and other BS within a network in a country. The cell using sub-band blanking can be viewed as a cell with some unused RBs.

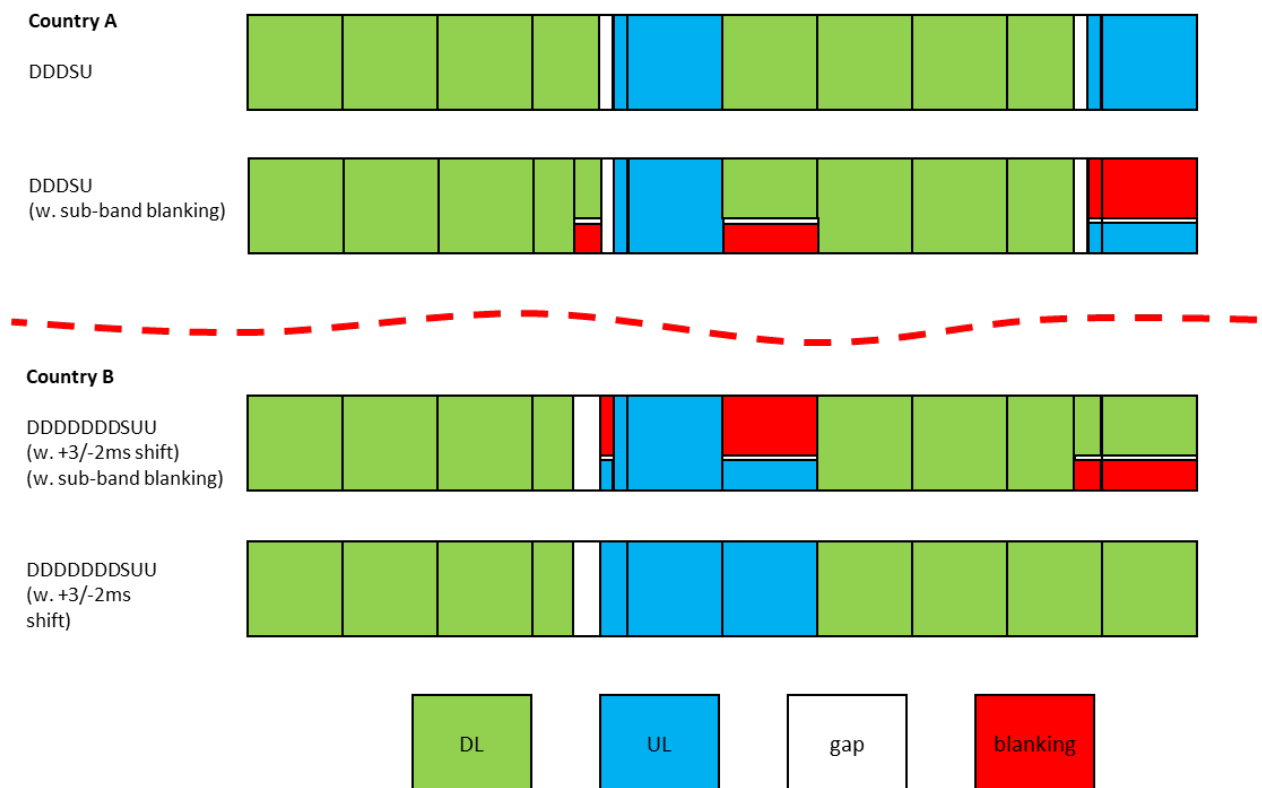

Figure 14: The operation of SBB within and outside the SBB implementation zone in a country

In case of different frequency assignments in neighbouring countries, a more detailed level of agreement is needed between the different operations.

3.2.3 Implementation aspects and interoperability

The control channel position is flexible in NR, which gives flexibility in terms of DL/UL partition within the flexible slot. Between different cells, there is no need for an alignment of the control channels. Therefore the information required for border coordination is the RBs to be blanked in each slot. No coordination between equipment from different vendors is required except for the RBs to be blanked in each slot, considering the frequency allocations to different operators on either side of the border. Considering a multi-vendor, multi-operator scenario, this can result in significant implementation changes to ensure that control channels are limited to specific sub-bands. Further detailed study is required to understand its impact. Specific configurations will need to be applied to different networks.

Sub-band blanking comes at the cost of implementation complexity, especially at the base station where different frequency resource blocks have to be blanked for different operators, with potential implications on the implementation of control channels to be considered. Base stations are still subject to cross-link interference from other base stations transmitting in the adjacent RBs within the same channel. While it is understood that 3GPP technical specifications already enable the blanking of RBs, it should be noted that requirements for out-of-band and blocking performance assume that the two systems are operating on adjacent channels, and there are currently no requirements defined in 3GPP specifications to address co-channel adjacent resource-block interference or blocking.

Sub-band blanking might require additional baseband filters within a channel bandwidth on both the transmitter and receiver side to get the required cross-link interference rejection to be equivalent to adjacent channel operation. Such additional filtering requires additional studies. It is not implemented in current products and no product requirement has been received at the time of writing.

Since in the base station, the transmitter is ON while only a portion of the downlink is used within the specified channel bandwidth, there are no defined base station RF requirements for in-band resources which are blanked. A guard band of some resource blocks, reserved between the downlink and uplink sub-bands, can reduce the impact of leakage between the sub-bands. The exact size of the guard band needs further consideration. To address in-band blocking, filtering at the victim BS receiver side might be required. Such additional filtering might be difficult to implement since filtering will be required for different slots.

3.2.4 Sub-band blanking in a multi operator scenario

An example for overlapping spectrum scenarios is depicted in Figure 15. Here, across three different countries operators operate in the frequency range 3490-3710 MHz. The operators in country A apply DDDDDDSUU +3/-2 ms while the operators in country B and C use DDDSU for the frame structure. Operator A1 is overlapping with Operators B1 and C1 across the border. One of many possible sub-band blanking configurations for the operators is depicted in the figure as an example solution.

Operator C2 across the border can find a sub-band blanking solution that will work for frequency ranges overlapping with both Operators B1 and B2 in country B as well as with Operators A2 and A3 in country A. The key is to alternate the relative locations of the DL and UL sub-bands on both sides of the border, allowing sub-band blanking to still be utilised.

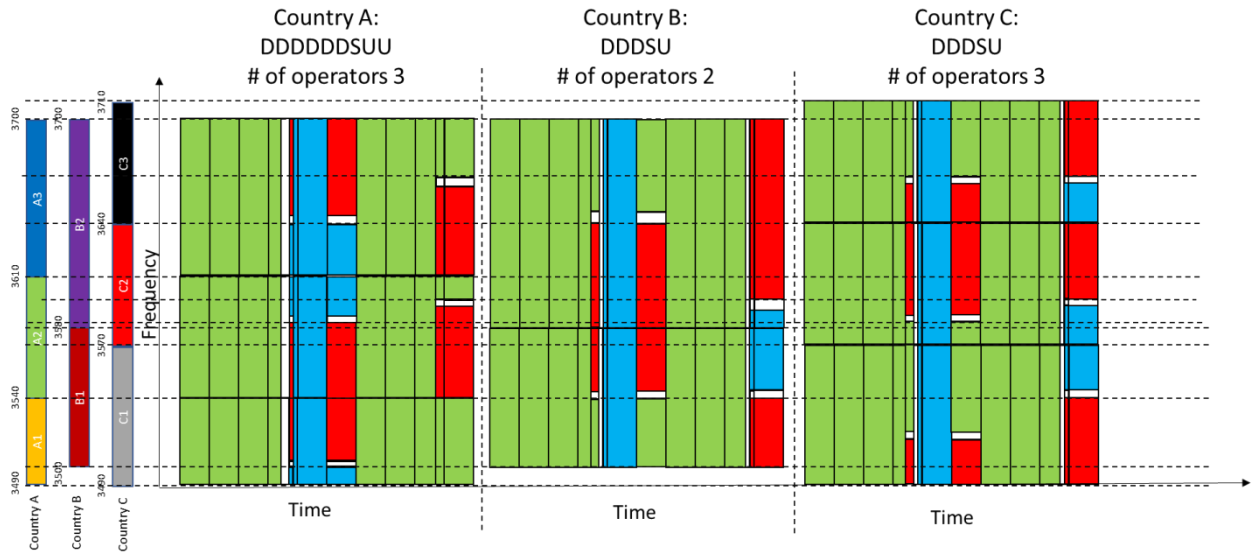

Figure 15: Sub-band blanking configuration in a multi operator scenario

The solution presented in the Figure 15 is only one possible approach, other solutions which fit better specific deployment scenarios can also be investigated. This increased flexibility enabled by sub-band blanking requires an agreement between the MNOs on additional parameters.

As shown in the Figure 15, the impact of sub-band blanking on the available resources will be different for the different operators involved in the cross-border coordination process (it depends on the channel bandwidths available to the operators and on their position of the spectrum assignments within the band). This will add complexities to negotiations between operators.

3.2.5 Sub-band blanking for the frames recommended in the ECC Recommendation (20)03

As indicated in Section 2, CEPT has recently issued ECC Recommendation (20)03 [2] regarding TDD MFCN frame structures to be used in cross-border coordination in order to facilitate the negotiation of bilateral/multilateral agreements between administrations and facilitate operator arrangements.

The CEPT administrations are encouraged to use the frame structures DDDSU and DDDDDDSUU (with the necessary time offset)/DDDSUDDDD for TDD networks in the frequency band 3400-3800 MHz in order to facilitate cross-border coordination. Sub-band blanking has been analysed in this context.

3.2.5.1 Sub-band blanking impact on capacity

Sub-band blanking enables a customizable exchange between the DL and UL resource blocks to be blanked. For the assumed frame structures (frame A and frame B), sub-band blanking allows to achieve a trade-off between a small loss of UL resource blocks with the possibility to still use DL resource blocks in slots. In particular, compared to fully blanking the OFDM symbols, this could allow increased DL control channel and payload capacity and enable a higher flexibility for the SSB configuration, which can benefit the cells at the borders.

In addition, this limitation in the number of UL RBs does not cause any UL coverage loss for the cell edge UEs. Since these cell edge UEs can only use a small portion of the UL band due to their power limitations, the UL sub-band suffices to schedule those UEs at the same duty cycle.

Figure 16 shows the impact with and without sub-band blanking applied to the frame A and frame B. Sub-band blanking enables a compromise between DL and UL capacity loss. This is enabled by using a part of the band in the flexible slots as DL in one network while the other network employs sub-band blanking of UL resources on this part of the band. By ensuring the availability of DL resources in all flexible slots, more flexibility in SSB and PDCCH scheduling is provided. The DL and UL bandwidth

allocation within the flexible slots can be adjusted such that the DL sub-band includes at least the frequency resources for SSB.

This improvement in the DL comes at the cost of UL capacity loss. However, the UL duty cycle and therefore UL coverage and timeline may only experience limited impact. The coverage limited UEs have enough power to use only a small portion of the bandwidth. Therefore, they can still be scheduled the same frequency allocation during the flexible “UL sub-band” slots without experiencing much throughput degradation. Since the UL duty cycle is unchanged, feedback loops such as HARQ, CSI reporting and SR transmissions are not impacted, and timelines can be maintained. For PRACH, the system information transmitted in the cell using sub-band blanking must ensure that the sub-band blanked uplink resources are not used for initial access. Since sub-band blanking of the UL slots is also periodic, it is possible to avoid RACH occasions that conflict with the blanked resources. Other reference signals in UL and DL are scheduled by the 5G NR BS within each cell. Therefore, the 5G NR BS considers the blanked sub-band for the scheduling of SRS and other reference signals.

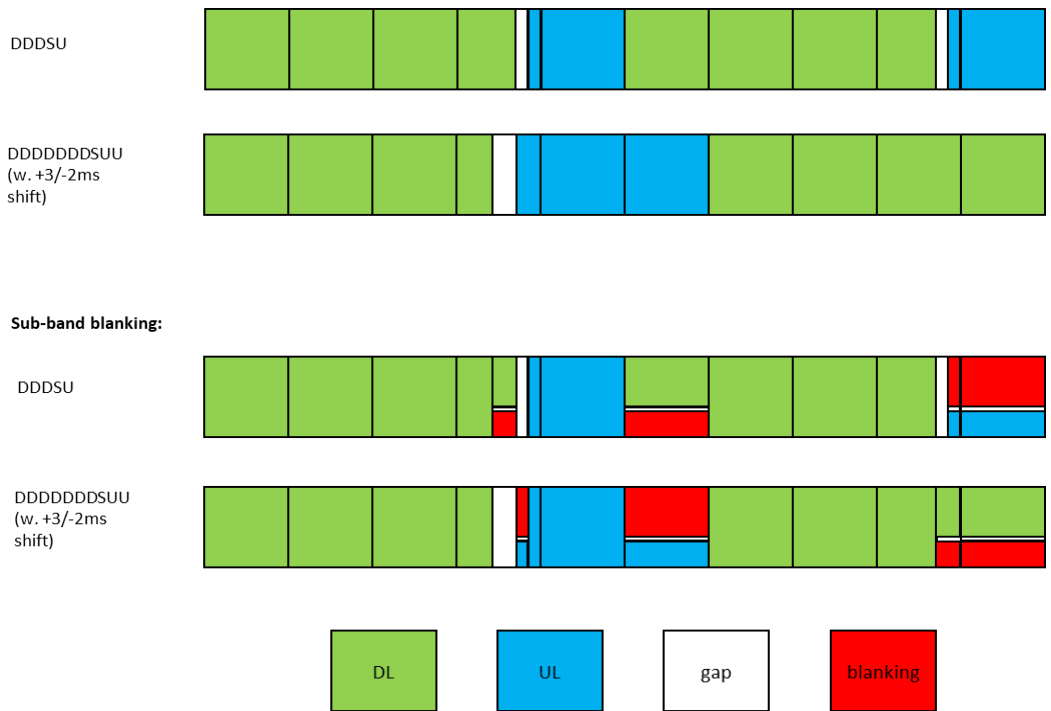

Figure 16: Example of sub-band blanking and equivalent baseline structure

In Table 3, an example of sub-band blanking configuration is shown considering the two frame structures recommended in ECC Recommendation (20)03 [2] (i.e. DDDDDDDSUU +3/-2 ms and DDSU) between two operators. The table also summarises the DL and UL symbol loss compared to a non-blanking scenario.

Table 3: Examples of downlink symbol loss in a single frame (10 ms) due to sub-band blanking

Frame structures, 30 kHz SCS		DL	DL Blanked	GAP	UL	UL Blanked	TOTAL
Frame A i.e. DDDSU (S=10:2:2)	No blanking	208	0	8	64	0	280
	w. sub-band blanking ¹⁶	195.1	12.9	8	42.6	21.4	280
	Delta w.r.t no blanking	-6.2%			-33.4%		
Frame B i.e. DDDDDDSUU (+3/-2ms offset) or DDDSUUDDDD (S=6:4:4)	No blanking	208	0	8	64	0	280
	w. sub-band blanking	195.1	12.9	8	42.6	21.4	280
	Delta w.r.t no blanking	-6.2%			-33.4%		

As an example, the 217 RBs available for an 80 MHz carrier with 30 kHz SCS, are divided into 140 DL RBs, 5 Guard RBs (noting that the 5 RBs might not be sufficient to mitigate the cross-link interference) and 72 UL RBs. For the symbols that are subject to sub-band blanking, only a percentage of the symbol is counted as available. In other words, 64.52% of the symbol is available for DL, 33.18% of the symbol is available for UL and 2.3% is left unused for the guard band. Other divisions between DL/UL are possible subject to agreement between operators.

Table 3 contains a fractional number which can be interpreted as the average number of full symbols (made of 217 RBs), which are allocated to a specific domain (DL or UL), within a frame¹⁷. In the following, a resource block (RB) is defined as 12 consecutive subcarriers in the frequency domain and one symbol in time domain. The fractional numbers in the table are obtained by dividing the number of specific RBs in a frame, e.g., all DL or UL RBs in a frame, with the total number of RBs in one symbol, i.e., 217 RBs for 80 MHz. A detailed calculation on how the numbers are derived for the DL in the no blanking and sub-band blanking case is described in the following two bullets:

- For the DL symbols in the no blanking case, $45136/217 = 208$ symbols are obtained, using 45136 DL RBs in a frame;
- For the case of sub-band blanking $42364/217 = 195.1$ DL symbols are obtained, where $172*217+36*140 = 42364$ corresponds to the number of DL RBs in a frame. Here, 172 corresponds to the DL symbols that are not blanked, while 36 symbols are sub-band blanked. The symbols without sub-band blanking have 217 RBs per symbol and the sub-band blanked symbols contain 140 DL RBs in the configuration investigated in the table.

This methodology is adopted to account for the frequency split enabled by sub-band blanking in the flexible slot and eases the comparison between the frames with no blanking and the frames with sub-band blanking.

In the above table, 36 symbols are subject to be blanked with sub-band blanking in the DL part. Therefore, 64.52% of 36, which is 23.1 symbols are used for DL and remaining 12.9 symbols are DL blanked which will result with 6.2% of DL symbol loss percentage. For the UL, half of the 64 UL symbols are subject to sub-band UL blanking ($2*(2+14) = 32$). 33.18% of those 32 symbols, which is 10.6 symbols, are available for UL and 21.4 symbols are UL blanked which will result with 33.4% UL symbols loss percentage.

With sub-band blanking, $12.9/36 * 100 = 35.8\%$ of 36 DL symbols and $21.4/32 * 100 = 67\%$ of UL 32 symbols are blanked; adding up to a total of $12.9+21.4 = 34.3$ symbols, which is $34.3/280 * 100 = 12.25\%$ of overall symbols. Even though there is loss due to guard band requirement, the overall number of blanked symbols is less with sub-band blanking. The reason is that some of the blanking is shifted to

¹⁶ For this example, sub-band blanking assumes 80 MHz BW, 30 kHz subcarrier spacing and total of 217 RBs.

¹⁷ Frame duration is 10 ms

UL symbols. In Table 3 above, the delta between sub-band blanking with respect to no blanking is determined from a resource allocation perspective. Therefore, it is based on the amount of resource blocks which are blanked and does not account for potential degradation due to cross link interference which could affect the sub-band blanking case. System level simulations would be required in order to assess cross-link interference impact.

To analyse the impact of the DL/UL split of the RBs in the flexible slot, the number of sub-band blanked RBs is analysed for two different options which are also depicted in Figure 17, noting that the 5 RBs might not be sufficient to mitigate the cross-link interference:

- 1 Option 1: DL 140 RBs, UL 72 RBs, and 5 RBs for guard band;
- 2 Option 2: DL 60 RBs, UL 152 RBs, and 5 RBs for guard band.

**Sub-band blanking Option 1:
140 DL/72 UL RBs**

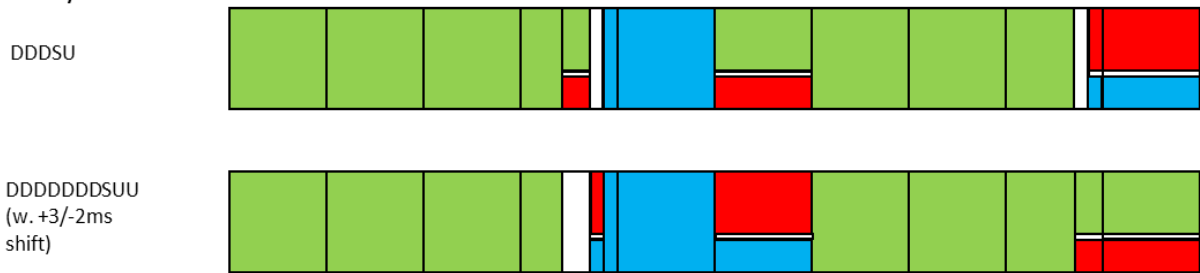

**Sub-band blanking Option 2:
60 DL/152 UL RBs**

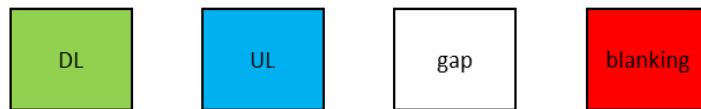
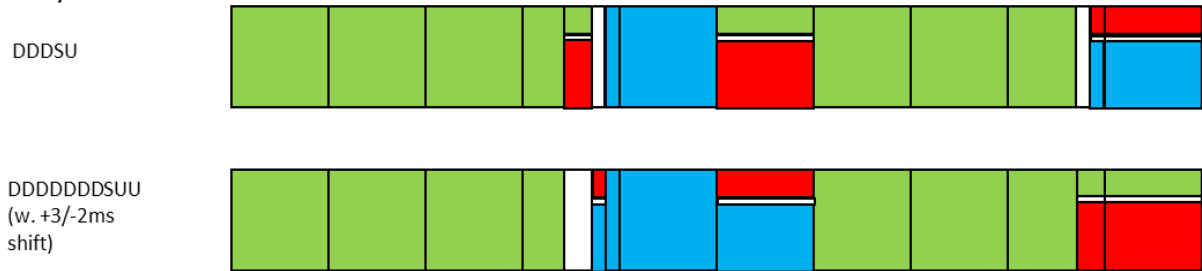

Figure 17: Different sub-band blanking configurations

of DL Blanked RBs vs. UL Blanked RBs in a single frame (10ms) due to SB blanking for single Network, RBs=217, 5 Guard RBs

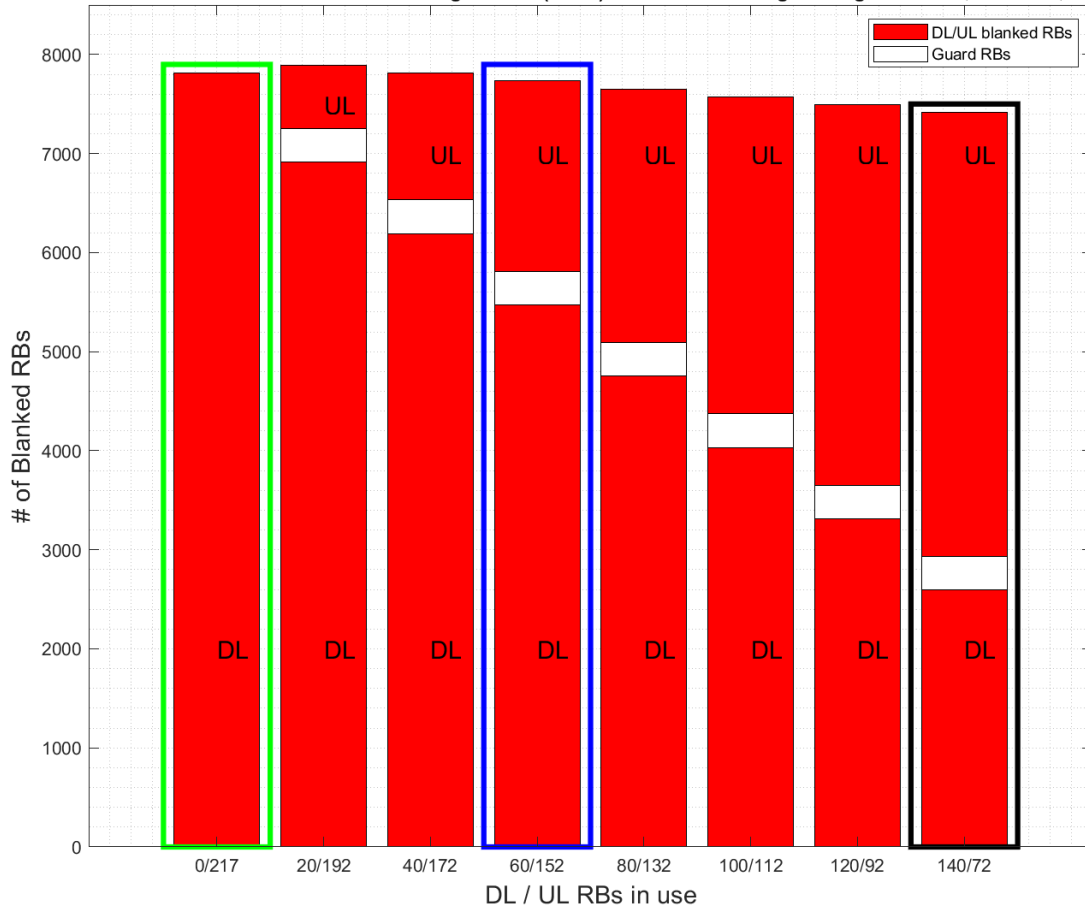

Figure 18: Number of DL/UL blanked RBs for different SB blanking configurations

Figure 18 depicts the number of DL and UL blanked RBs for different DL/UL RB configurations assuming 5 guard RBs and when considering one 10 ms frame in a single network. The numbers shown on the x-axis represent the DL/UL RBs which are in use in the flexible slots and the y-axis represents the total number of blanked RBs due to DL and UL sub-blanking including the guard RBs. For instance, in the first configuration, which is highlighted in green in Figure 18, the total number of DL blanked RBs is 7812 (36 symbols*217 RBs) as the DL is completely blanked and 0 guard RBs are used.

The number of DL/UL blanked RBs for the example presented in Table 3, with 140 DL RBs and 72 UL RBs, is highlighted in black in Figure 18 and referred to as option 1. The DL symbol loss is 6.2 % and UL symbol loss is 33.4 % for option 1 with 140 and 72 RBs for DL and UL. At the separation distance the overall UL TP reduction can be approximated as 33.4% + 5% = 38.4%. The reduction in the UL throughput loss by additional 5% due to cross-link interference is only valid for an appropriate separation distance and rapidly decays for higher distances. Separation distance will vary for the cases depicted in Figure 18. When different cases are agreed between operators, the separation distance needs to be recalculated and the network configuration needs to be adjusted accordingly.

Other configurations can be used with a different DL and UL RB split as illustrated in Figure 18. For instance, option 2 using 60 RBs for DL and 152 RBs for UL, which is highlighted in blue in Figure 18, decreases the number of UL blanked RBs and increases the number of DL blanked RBs compared to option 1. For this option 2, the DL TP loss is 12.5% and the UL TP reduction is only 14.9% due to blanking of UL resources. Hence the overall UL TP loss for this configuration can be approximated as 14.9% + 5% = 19.9% at an appropriate separation distance.

Even though there is loss due to the required guard band, the overall number of sub-band blanked RBs (DL and UL combined) reduces with the reduction of the sub-band blanked RBs in DL. The reason is that some of the blanking is shifted to UL direction where the number of symbols impacted by UL sub-band blanking is 32 symbols compared to 36 symbols in DL direction. For instance, option 2, which is

highlighted in blue, has 7732 blanked RBs. On the other hand, option 1, which is highlighted in black, has in total 7412 blanked RBs (including guard RBs) which results in a saving of 320 RBs.

As has been highlighted, Sub-band blanking enables a configurable trade-off between UL and DL capacity loss due to blanking and therefore can enable flexibility for the operation across the borders. However, further studies are required on this technique.

4 ANALYSIS OF FIELD STRENGTH VALUES FOR TDD MFCN NETWORK DEPLOYMENT IN BORDER AREAS

4.1 METHODOLOGY TO DERIVE THE FIELD STRENGTH VALUES

ECC Recommendation (15)01 [1] is a reference document for negotiating bilateral or multilateral cross-border coordination agreements. The signed bilateral agreements between neighbouring countries must be respected by mobile operators when they plan and deploy their MFCN networks.

As mentioned in section 1.2, in the revision of ECC Recommendation (15)01 in 2019 [1], the field strength value of $0 \text{ dB}\mu\text{V/m}/(5 \text{ MHz})$ at 3 m was obtained. Such a value can lead in practice to very large exclusion zones in cross-border areas. In order to facilitate the deployment of TDD MFCN in border areas, there is a need to study the field strength values with different more realistic deployment options and to analyse operational solutions for efficient usage of spectrum.

Based on the simulation assumptions described in ANNEX 1, the field strength levels are obtained by using the following two steps:

First step: Monte Carlo simulations are performed in order to obtain the separation distance D between the reference cell of the interfering Network A and victim Network B, as shown in Figure 19, is obtained based on an acceptable interference level. Results from those simulations are in annex 2.

Second step: then field strength values are derived from this distance D . All field strength values are computed at 3m height. The resulting field strength values results are in ANNEX 2 Those values are computed with a single transmitting BS located at distance D_x from the borderline, and a victim receiver located at the borderline. The relationship between D and D_x is :

- For unsynchronised operation modes without DSB, $D_x=D/2$ since it is assumed that an exclusion zone is shared between operators
- For operation mode with DSB, $D_x=D$ since victim BS implementing DSB can be deployed at the borderline
- For synchronised operation, since the network layout is composed with continuous hexagons from network A to B, we have $D_x=\text{Cell Range}=2\times\text{Cell Radius}$ and $D=3\times\text{Cell Radius}$

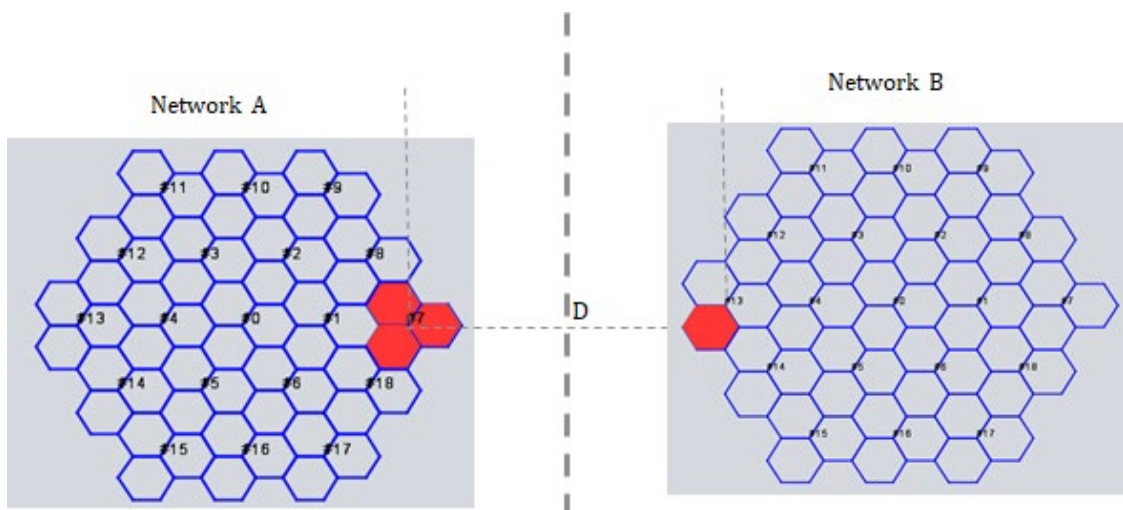

Figure 19: Simulation scenario

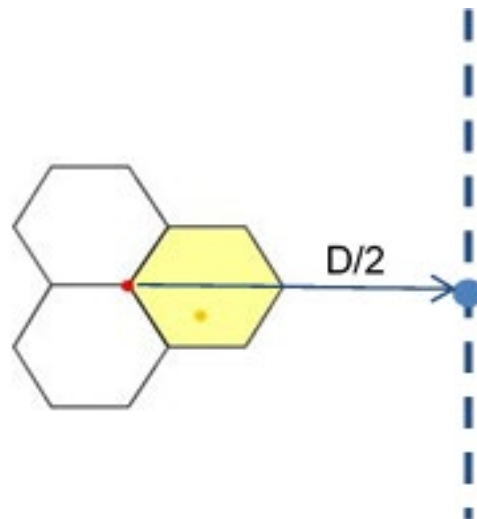

Figure 20: Field strength value simulation for unsynchronised operation modes without DSB

For AAS BS, depending on the channel type, data channels or SSB control channels, two different antenna patterns are used, i.e., a beamforming AAS antenna pattern for data channel and a fixed antenna pattern (which itself can be implemented in two different ways as described below) for SSB control channel, and different field strength values are obtained for each channel type.

For AAS BS, in total three field strength values are obtained:

- Median data field strength value in $\text{dB}\mu\text{V}/\text{m}/(5 \text{ MHz})$, obtained by simulating the behaviour of AAS BS with beamforming AAS model;
- Maximum data field strength value in $\text{dB}\mu\text{V}/\text{m}/(5 \text{ MHz})$, obtained by using the maximum antenna gain, i.e., assuming the AAS main beam is always pointing to the borderline. This data field strength value gives the upper bound field strength at the borderline¹⁸;
- SSB field strength values in $\text{dB}\mu\text{V}/\text{m}/(30 \text{ kHz})$ using SSB vertical antenna pattern/gain with two types of SSB antenna patterns are considered, single beam and multi-beam depending on equipment implementations. These SSB implementation specificities need to be taken into account in the determination of SSB field strength values, with multi-beam implying a higher antenna gain for the SSB.

For non-AAS BS, the fixed antenna vertical pattern/gain and tilt is used for both data and control channels and therefore the same field strength values in $\text{dB}\mu\text{V}/\text{m}/(5 \text{ MHz})$ apply to both channel types.

Five operation modes are addressed in these Report, namely:

- 1 Synchronised operation
- 2 Unsynchronised operation with partial duplex misalignment and ECC Recommendation (20)03 [2] recommended scenario with Downlink Symbol Blanking (DSB)
- 3 Unsynchronised operation with partial duplex misalignment and ECC Recommendation (20)03 recommended scenario without DSB
- 4 Fully-unsynchronised operation (100% duplex misalignment) without preferential frequency blocks
- 5 Fully-unsynchronised operation (100% duplex misalignment) with preferential frequency blocks

¹⁸ It should be noted that this is a theoretical worst-case upper bound. In real deployments, the AAS beam will not be permanently pointing towards one direction since the maximum Gain is directed to the UEs which are randomly distributed

4.2 SUMMARY OF SIMULATION RESULTS AND FIELD STRENGTH VALUES

The data and SSB field strength values for the five operation modes listed above are summarised in the following tables. These values could be the basis for further consideration for the revision of ECC Recommendation (15)01 [1].

Table 4: field strength values at borderline 3 m height for operation modes 3 and 2

AAS mode	Scenario	Unsynchronised operation based on ECC Recommendation (20)03 (partial duplex misalignment) without DSB						Unsynchronised operation based on ECC Recommendation (20)03 (partial duplex misalignment) with DSB For DSB implementation zone					
		Suburban			Rural			Suburban			Rural		
	Environment	10%	20%	30%	10%	20%	30%	10%	20%	30%	10%	20%	30%
AAS to AAS	E_median (dB μ V/m/(5 MHz))	4.59	13.09	21.49	10.59	21.59	31.49	-12.79	-3.80	6.17	-7.82	4.04	14.54
	E_max (dB μ V/m/(5 MHz))	34.35	42.65	51.05	27.05	37.95	47.95	17.23	26.15	35.85	8.70	20.45	30.99
	E_SSB single-beam (dB μ V/m/(30 kHz))	-0.61	7.79	16.36	-3.64	7.29	17.34	-17.85	-8.88	0.90	-22.02	-10.26	0.31
	E_SSB multi-beam (dB μ V/m/(30 kHz))	-4.09	4.63	13.70	2.12	13.09	23.20	-21.69	-12.56	-2.52	-16.30	-4.51	6.08
AAS to Non-AAS	E_median (dB μ V/m/(5 MHz))	-2.63	3.64	8.13	11.26	21.53	23.02	-19.92	-13.56	-8.82	-6.85	3.94	5.54
	E_max (dB μ V/m/(5 MHz))	27.34	33.59	38.02	27.72	37.87	39.56	10.05	16.49	21.17	9.45	20.37	22.14
	E_SSB single-beam (dB μ V/m/(30 kHz))	-7.68	-1.38	3.10	-2.97	7.21	8.91	-25.06	-18.60	-13.89	-21.27	-10.34	-8.56
	E_SSB multi-beam (dB μ V/m/(30 kHz))	-11.33	-4.87	-0.25	2.79	13.01	14.72	-28.98	-22.44	-17.66	-15.54	-4.59	-2.81
Non-AAS to AAS	E (dB μ V/m/(5 MHz))	11.42	18.77	28.00	17.07	25.61	36.92	-4.52	2.64	11.42	1.59	9.98	20.66

Table 5: field strength values at borderline 3 m height for operation modes 4, 5 and 1

AAS mode	Scenario	Fully unsynchronised (worst-case)						Fully unsynchronised with preferential freq.			Synchronised	
	Environment	Suburban			Rural			Suburban			Suburban	Rural
	UL TP Loss	10%	20%	30%	10%	20%	30%	10%	20%	30%	(DL) 5%	(DL) 5%
AAS to AAS	E_median (dBµV/m/(5 MHz))	-4.41	4.49	8.59	2.19	10.49	15.89	37.19	44.39	49.59	77.99	78.79
	E_max (dBµV/m/(5 MHz))	25.65	34.35	38.35	18.65	27.05	32.35	65.75	72.05	76.55	99.05	98.05
	E_SSB single-beam (dBµV/m/(30 kHz))	-9.39	-0.61	3.43	-12.06	-3.64	1.67	31.74	38.67	43.66	69.20	68.84
	E_SSB multi-beam (dBµV/m/(30 kHz))	-13.08	-4.09	0.09	-6.32	2.12	7.45	31.13	39.91	45.91	75.82	75.61
AAS to Non-AAS	E_median (dBµV/m/(5 MHz))	-7.22	-2.63	0.82	4.04	11.26	15.54	31.69	35.49	39.47	77.59	
	E_max (dBµV/m/(5 MHz))	22.68	27.34	30.81	20.37	27.72	31.99	60.56	64.19	67.74	98.96	
	E_SSB single-beam (dBµV/m/(30 kHz))	-12.37	-7.68	-4.19	-10.34	-2.97	1.31	26.23	30.07	33.90	69.09	
	E_SSB multi-beam (dBµV/m/(30 kHz))	-16.12	-11.33	-7.75	-4.59	2.79	7.09	24.64	29.14	33.80	75.73	
Non-AAS to AAS	E (dBµV/m/(5 MHz))	5.94	11.42	14.79	8.26	17.07	21.66	59.01	63.68	69.69	83.89	51.97

Calculation explanation

Operation mode 1, synchronised operation: the interference level is considered as acceptable if the DL throughput loss is below 5%, which is always the case for all considered synchronised scenarios in annex 2. The FS values for synchronised operation in Table 5 are taken from cell range R=300 m in suburban areas and cell range R=500 m in Rural areas. The field strength values with other cell ranges can be found in annex 3.

Operation mode 2, unsynchronised operation with partial duplex misalignment and ECC Recommendation (20)03 recommended frame structures with DSB: as described in section 3.1.2 and 3.1.5.3, when DSB is applied to both networks across the borderline in a sufficient area ("DSB implementation zone"), there is no more collision from downlink time slots to uplink time slots. The remaining interference is from Downlink to Downlink, therefore the field strength values for operation mode 1 (synchronised) applies to the MFCN BS activating DSB. DSB is not required to be activated if FS from the BS at the border @3 m is below the FS that defines the DSB implementation zone (i.e. FS computed for operation mode 2. This field strength value applies to all BS that do not implement DSB).

Operation mode 3, unsynchronised operation with partial duplex misalignment and ECC Recommendation (20)03 recommended frame structures without DSB: in this operation mode, misaligned duplex directions only occur in a portion of the frame. The field strength values are obtained by reusing the worst-case results of operation mode 4 with a correction factor of 0.5 (i.e. divide by two the UL TP loss from operation mode 4).

Operation mode 4, fully unsynchronised operation with non-preferential frequency blocks: in this operation mode, misaligned duplex directions between two adjacent operators occur for the whole frame duration. This provides the worst-case field strength values.

Operation mode 5, fully unsynchronised operation with preferential frequency blocks: in this operation mode, the field strength trigger value is determined to keep the adjacent channel interference below an acceptable UL throughput loss.

For all unsynchronised cases without DSB, field strengths have been computed with the assumption that the required isolation or separation distance is equally shared between the two countries. For

operation mode with DSB, the field strength is computed with $D_x=D$ since victim BS implementing DSB can be deployed at the borderline.

DSB implementation zone: for determining the DSB implementation zone, it is preferred to have a field strength value without distinguishing between suburban or rural area and or between single beam SSB or multi-beam SSB. Table 6 below gives average values between suburban and rural scenarios (from ANNEX 3:annex 3) in order to ease the cross-border coordination at 10%, 20%, and 30% UL throughput loss.

Table 6: FS value for determining the DSB implementation zone

UL Throughput Loss (%)	10%	20%	30%
Median data FS (dB μ V/m/(5 MHz)) @3 m height	-10.30	0.12	10.40
SSB FS (dB μ V/m/(30 kHz)) @3 m height	-19.46	-9.00	1.19

DSB implementation for non-AAS BS using LTE technology is not envisaged.

5 CONCLUSIONS

This Report addresses cross-border coordination for MFCN (including AAS BS and non-AAS BS¹⁹) in the following operation modes:

- 1 Synchronised operation²⁰
- 2 Unsynchronised operation with partial duplex misalignment and ECC Recommendation (20)03 [2] recommended scenario²¹ with Downlink Symbol Blanking (DSB)
- 3 Unsynchronised operation with partial duplex misalignment and ECC Recommendation (20)03 recommended scenario without DSB
- 4 Fully-unsynchronised operation (100% duplex misalignment) without preferential frequency blocks
- 5 Fully-unsynchronised operation (100% duplex misalignment) with preferential frequency blocks

Two interference mitigation solutions, downlink symbol blanking and sub-band blanking, are investigated and described. The inter-operability, impact on coverage and DL/UL capacity loss, implementation zone, etc. are analysed for these mitigation solutions.

Downlink symbol blanking (DSB) is a feature implemented in the 5G NR system allowing the base stations' schedulers to switch off transmissions ("blanking") of those downlink symbols ("blanked DL symbols") of each network that correspond to simultaneous uplink reception or simultaneous gap symbols for the other network, to avoid the downlink to uplink interference. DSB is a base station scheduler feature applied to base stations in the geographical "DSB implementation zone". It does not require standardisation by 3GPP and is product-implementation dependent. At the time of writing, it is anticipated that there should not be any interoperability problem between different vendors when DSB is implemented according to the recommended scenario in ECC Recommendation (20)03. When using any of the two frame structures (frame A and B) recommended in ECC Recommendation (20)03, the impact of downlink symbol blanking on DL capacity is evaluated as 17.3% DL capacity loss when DSB is implemented by blanking both traffic and control channels. The downlink symbol blanking can have some impact on 5G-NR coverage as well in some cases although this has not been quantified in this report. DSB is not expected to be implemented for LTE-TDD in a near future and therefore its anticipated performance impacts on channel estimation due to the blanking of the LTE Cell-specific Reference Signal have not been quantified in this report.

Another mitigation technique called sub-band (SB) blanking has been assessed in this Report. This technique relies on avoiding different duplex directions on the same resource blocks at the border. It enables a configurable trade-off between UL and DL capacity loss due to blanking. However, even though it avoids the high interference that would result from different duplex directions on the same resource blocks, it does not avoid interference between adjacent resource blocks. Further studies and possible standardisation work are still required to determine the feasibility (e.g. with regards to blocking and unwanted emissions), the exact size of the guard band, the residual cross-link interference, and implementation complexity at the base station, noting that there are currently no requirements defined in 3GPP specifications to address either co-channel adjacent resource-block interference or blocking. SB blanking is therefore considered not yet ready as a mitigation technique and no corresponding field strength values have been derived in this Report.

In the objective to derive the operational field strength trigger values for each of the five cross-border operation modes, realistic assumptions for MFCN networks including AAS BS and non-AAS BS system parameters and deployment scenarios have been established and described in Annex 1. Based on

¹⁹ In this Report, it is assumed that non-AAS BS are using the 4G/LTE technology and AAS BS are using 5G/NR technology

²⁰ See ECC Report 216 [3] and ECC Report 296 [4]

²¹ ECC Recommendation (20)03 recommended scenario assumes frame A is used in one country and frame B in the other country and implies agreement on a common phase clock reference and partial duplex misalignment.

these assumptions, cross-border network interference Monte Carlo simulations for the five cross-border operation modes have been carried out for the following three cases:

- 1 AAS BS to AAS BS (5G to 5G);
- 2 AAS BS to non-AAS BS (5G to 4G);
- 3 non-AAS BS to AAS BS (4G to 5G).

In this Report the assumption was made that the case of non-AAS BS to non-AAS BS will not happen in the future in the frequency band 3400-3800 MHz since the market is 5G NR driven. The interference simulation methodology and the simulation results are described in Annex 1 and Annex 2 respectively.

Three types of field strength values are derived from the simulation results for AAS BS:

- Median data field strength value in dB μ V/m/(5 MHz), obtained by simulating the behavior of AAS BS with beamforming AAS model;
- Maximum data field strength value in dB μ V/m/(5 MHz), obtained by using the maximum antenna gain, i.e., assuming the AAS main beam is always pointing to the borderline. This data field strength value gives the upper bound field strength at the borderline;
- SSB field strength values in dB μ V/m/(30 kHz) using SSB vertical antenna pattern/gain. Two types of SSB antenna patterns are considered, single beam and multi-beam depending on equipment implementations. These SSB implementation specificities need to be taken into account in the determination of SSB field strength values, as multi-beam implying a higher antenna gain for the SSB.

For non-AAS BS, the fixed antenna vertical pattern/gain and tilt is used for both data and control channels and therefore the same field strength values in dB μ V/m/(5 MHz) apply to both channel types.

All field strength values are obtained at 3 m height.

The simulated or calculated field strength values for the five cross-border operation modes are summarised in section 4.2 and in tables below. Those field strength values will be the basis for further consideration in the revision of the ECC Recommendation (15)01 [1].

Table 7: field strength values at borderline 3m height for operation modes 3 and 2

AAS mode	Scenario	Unsynchronised operation based on ECC Recommendation (20)03 (partial duplex misalignment) without DSB						Unsynchronised operation based on ECC Recommendation (20)03 (partial duplex misalignment) with DSB For DSB implementation zone					
		Suburban			Rural			Suburban			Rural		
	Environment	10%	20%	30%	10%	20%	30%	10%	20%	30%	10%	20%	30%
AAS to AAS	E _{median} (dB μ V/m/(5 MHz))	4.59	13.09	21.49	10.59	21.59	31.49	-12.79	-3.80	6.17	-7.82	4.04	14.54
	E _{max} (dB μ V/m/(5 MHz))	34.35	42.65	51.05	27.05	37.95	47.95	17.23	26.15	35.85	8.70	20.45	30.99
	E _{SSB single-beam} (dB μ V/m/(30 kHz))	-0.61	7.79	16.36	-3.64	7.29	17.34	-17.85	-8.88	0.90	-22.02	-10.26	0.31
	E _{SSB multi-beam} (dB μ V/m/(30 kHz))	-4.09	4.63	13.70	2.12	13.09	23.20	-21.69	-12.56	-2.52	-16.30	-4.51	6.08
AAS to Non-AAS	E _{median} (dB μ V/m/(5 MHz))	-2.63	3.64	8.13	11.26	21.53	23.02	-19.92	-13.56	-8.82	-6.85	3.94	5.54
	E _{max} (dB μ V/m/(5 MHz))	27.34	33.59	38.02	27.72	37.87	39.56	10.05	16.49	21.17	9.45	20.37	22.14
	E _{SSB single-beam} (dB μ V/m/(30 kHz))	-7.68	-1.38	3.10	-2.97	7.21	8.91	-25.06	-18.60	-13.89	-21.27	-10.34	-8.56

	E_SSB multi-beam (dB μ V/m/(30 kHz))	-11.33	-4.87	-0.25	2.79	13.01	14.72	-28.98	-22.44	-17.66	-15.54	-4.59	-2.81
Non-AAS to AAS	E (dB μ V/m/(5 MHz))	11.42	18.77	28.00	17.07	25.61	36.92	-4.52	2.64	11.42	1.59	9.98	20.66

Table 8: field strength values at borderline 3m height for operation modes 4, 5 and 1

AAS mode	Scenario	Fully unsynchronised (worst-case)						Fully unsynchronised with preferential freq.			Synchronised	
	Environment	Suburban			Rural			Suburban			Suburban	Rural
	UL TP Loss	10%	20%	30%	10%	20%	30%	10%	20%	30%	(DL) 5%	(DL) 5%
AAS to AAS	E_median (dB μ V/m/(5 MHz))	-4.41	4.49	8.59	2.19	10.49	15.89	37.19	44.39	49.59	77.99	78.79
	E_max (dB μ V/m/(5 MHz))	25.65	34.35	38.35	18.65	27.05	32.35	65.75	72.05	76.55	99.05	98.05
	E_SSB single-beam (dB μ V/m/(30 kHz))	-9.39	-0.61	3.43	-12.06	-3.64	1.67	31.74	38.67	43.66	69.20	68.84
	E_SSB multi-beam (dB μ V/m/(30 kHz))	-13.08	-4.09	0.09	-6.32	2.12	7.45	31.13	39.91	45.91	75.82	75.61
AAS to Non-AAS	E_median (dB μ V/m/(5 MHz))	-7.22	-2.63	0.82	4.04	11.26	15.54	31.69	35.49	39.47	77.59	
	E_max (dB μ V/m/(5 MHz))	22.68	27.34	30.81	20.37	27.72	31.99	60.56	64.19	67.74	98.96	
	E_SSB single-beam (dB μ V/m/(30 kHz))	-12.37	-7.68	-4.19	-10.34	-2.97	1.31	26.23	30.07	33.90	69.09	
	E_SSB multi-beam (dB μ V/m/(30 kHz))	-16.12	-11.33	-7.75	-4.59	2.79	7.09	24.64	29.14	33.80	75.73	
Non-AAS to AAS	E (dB μ V/m/(5 MHz))	5.94	11.42	14.79	8.26	17.07	21.66	59.01	63.68	69.69	83.89	51.97

For all unsynchronised cases without DSB, field strengths have been computed with the assumption that the required isolation or separation distance is equally shared between the two countries. Where DSB is implemented, the field strength values for synchronised operation are applicable at the border.

The DSB implementation zone is determined using an agreed field strength value from Table 6 in section 4.2, noting that different field strength values result in different UL throughput losses.

ANNEX 1: MFCN TECHNICAL PARAMETERS AND ASSUMPTIONS FOR SIMULATIONS

A1.1 SIMULATION ASSUMPTIONS

Table 9: Generic parameters

BS/UE mode	Parameter	Value	Notes
	Centre Frequency (MHz)	3600	Centre frequency of the 3400-3800 MHz band
	Propagation model	ITU-R P.1546 [8]	Intra-network : 50% location, 50% time. Interfering link : 50% location, 10% time. No clutter layer
AAS	BS Tx Power	200 W (53 dBm)	Maximum BS transmit power in the market.
	SCS (kHz)	30 kHz	Subcarrier spacing
	BS SSB BW (MHz)	7.2	Typical SSB bandwidth for NR : 20 RB i.e. 240 subcarriers x 30 kHz = 7.2 MHz
	BS SSB antenna gain (dBi)	Multi- beams: 24 dBi. Fixed beam: 17 dBi	
	BS ACLR (dB)	45dB	3GPP TS 38.104 [14]
	BS noise figure (dB)	5	5 dB is used in ECC Report 281[12] and 295 [13] (although 3 dB is considered more realistic)
	Antenna pattern	ITU-R M.2101 [15]	See also table below for suburban/rural detailed parameters
	Array Ohmic loss (dB)	2	
	Conducted power (before Ohmic loss) per antenna element (dBm)	35	The conducted power per element assumes 8x8x2 elements (i.e. power per H/V polarized element). Conducted Pwr per ant. Elem.= BS Conducted Pwr - 10*log 10(8x8)
	Antenna array configuration (Row x Column)	8 x 8 elements	8x8 means there are 8 vertical and 8 horizontal radiating elements. In the sub-array case, one implementation is 2 vertical radiating elements combined in a 2x1 sub-array
	Base station maximum coverage angle in the horizontal plane (degrees)	120	
	Antenna polarisation	Linear ±45°	
	Horizontal/vertical front-to-back ratio (dB)	30 for both H/V	30 for both H/V
Non-AAS	BW	20 MHz	In this Report, it is assumed that Non-AAS will rely on LTE 15 kHz SCS, although 5G-NR 30 kHz SCS could theoretically also exist with this configuration
	SCS (kHz)	15 kHz	
	Antenna pattern	Recommendation ITU-R F.1336 [16] (recommends 3.1), $k_a = 0.7$, $k_p = 0.7$, $k_h = 0.7$, $k_v = 0.3$, Horizontal beamwidth = 65°	Vertical 3 dB beamwidth: determined from the horizontal beamwidth by equations in Recommendation ITU-R F.1336 . Vertical beamwidths of actual antennas may also be used when available.
	Antenna polarisation	Linear/±45 degrees	
	Feeder loss	3 dB	

BS/UE mode	Parameter	Value	Notes
	Maximum base station output power (per cell)	49 dBm	The value for the BS output maximum power is given in case of MIMO 2 (with two antenna per cell)
	Maximum base station antenna gain	18 dBi	
	Maximum base station output power/sector (EIRP)	64 dBm	
UE	UE Tx Power (dBm)	23	3GPP 38.101 [9]
	UE antenna gain (dBi)	-4	ITU-R M.2292 [10]
	Data user body loss (dB)	0	Provided by a MNO
	HO margin (dB)	0	Provided by a MNO
	UE height (m)	1,5	ITU-R M.2292
	Wall Loss for indoor UE (dB) standard deviation (dB)	5	
	UE Power control parameter	CLx 95th percentile: 123.07 dB	Derived for the frequency band 3600 MHz from ECC Report 309 [11] for SEAMCAT
	BS-UE MCL	70	ITU-R M.2292
	UE noise figure (dB)	9	ITU-R M.2292
	UE ACLR (dB)	30 dB	3GPP TS 38.101
	UE ACS (dB)	33 dB	3GPP TS 38.101

Table 10: co-channel / adjacent-channel specific parameters

Parameter	Co-channel	Adjacent-channel	Notes
Channel bandwidth (MHz)	80 MHz	40 MHz	80 MHz is the typical allocation per operator in Europe (France & Germany). N.B. It is proposed to consider that the same maximum power will be used for AAS BS with a BW of 40 MHz and 80 MHz
AAS n_RB	217	106	maximum RB in the transmitted BW for an SCS of 30kHz, with 12 subcarriers per RB
BS SSB Tx Power	77 mW (19 dBm)	157 mW (22 dBm)	$200 \text{ W} / n_RB * 360 \text{ kHz} * 30 \text{ kHz}$
BS ACS	33.2 dB	36.2 dB	3GPP TS 38.104 [14]. (Calculated with -52 dBm ACS level and 5 dB noise figure)

Table 11: Suburban / rural specific parameters

	Parameter	Suburban	Rural	Notes
	Cell Range (m)	300	4000/1155 depending on simulations	Typical cell range with the existing radio sites in France
	UE Indoor/Outdoor percentage(%)	70/30	50/50	ITU-R M.2292 [10]
	Wall Loss for indoor UE (dB)	20	10	20 dB for urban in ITU-R M.2292
	BS antenna height (m)	25	35	
	Network loading	70%	50%	
	Mechanical downtilt (degrees)	6	3	Mechanical downtilt is typically an optimization parameter as it can reduce the inter-cell interference within a network and also decrease the interference in cross-border situations
AAS	Element gain (dBi)	6.4	7.1	Includes the 2dB array ohmic loss
	Maximum antenna Gain (dBi)	24.5	25.2	the maximum antenna gain has been calculated has follow : element antenna gain + 10xLog10 (8x8 elements)
	Horizontal/vertical 3 dB beam width of single element (degree)	90° for H, 65° for V	90° for H, 54° for V	
	Horizontal/Vertical radiating element spacing	0.5 of wavelength for H, 0.7 of wavelength for V	0.5 of wavelength for H, 0.9 of wavelength for V	
	Base station vertical coverage range (degrees)	90-120	90-100	given for the elevation angle θ , defined between 0° and 180° as in ITU-R M.2101 [15]

A1.2 SIMULATION SCENARIOS AND METHODOLOGY

The simulation scenario is illustrated in Figure 21. Two network clusters A and B are separated of distance D. Interference from network cluster A to network cluster B is simulated.

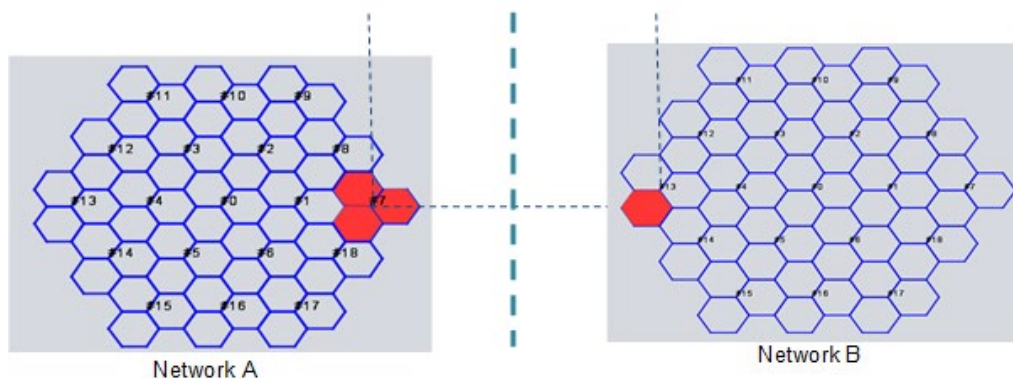
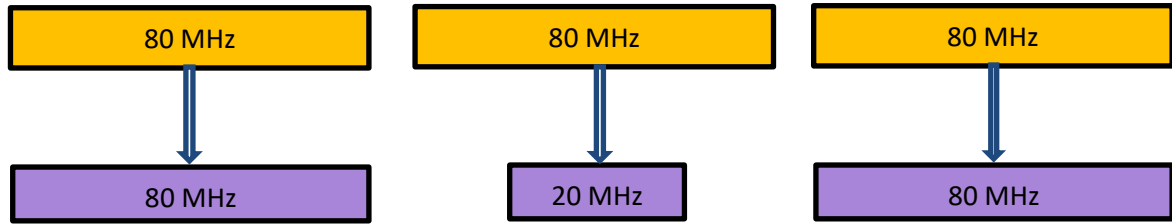

Figure 21: Simulation scenario between two TDD networks (Network A (Left) and Network B (Right))

As shown in Figure 21, two networks A and B are separated of distance D. In each network, UEs are randomly generated in each cell (1 UE per cell occupying the whole channel bandwidth), interference from network A to network B is simulated. First the Network B reference throughput is simulated as the throughput without interference from Network A, then the Network B throughput loss caused by the presence of interference from network A is simulated.

A1.2.1 Synchronised operation

In this case, Network A and B are in operation in co-channel, the co-channel interference from network A downlink to network B downlink is simulated.



a) AAS to AAS

b) AAS to non-AAS

c) non-AAS to AAS

Figure 22: Co-channel DL to DL

A1.2.2 Unsynchronised operation with non-preferential frequency blocks

In this case, Network A and B are in operation in co-channel, the co-channel interference from network A downlink to network B uplink is simulated.

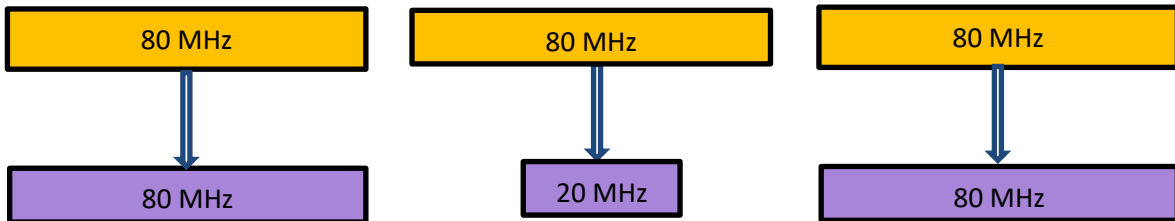

a) AAS to AAS

b) AAS to non-AAS

c) non-AAS to AAS

Figure 23: Co-channel DL to UL

A1.2.3 Unsynchronised operation with preferential frequency blocks

In this case, Network A and B are in adjacent band operation, the adjacent-channel interference from network A downlink to network B uplink is simulated.

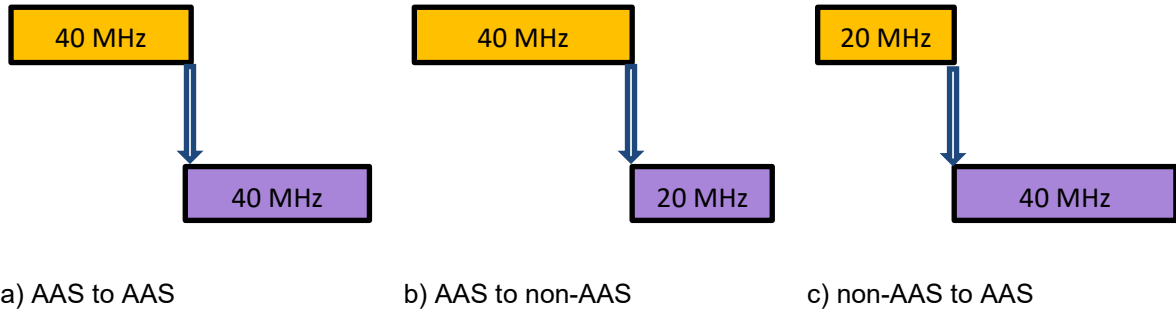

Figure 24: Adjacent channel DL to UL

A1.2.4 Unsynchronised operation with non-preferential frequency blocks and partial duplex misalignment, using the ECC Recommendation (20)03 [2] recommended scenario

For this case, the UL throughput loss is not directly simulated, but derived from the simulation results for Case 2 unsynchronised operation without preferential frequency blocks with a factor of 0.5 on the interference probability.

This scenario assumes that networks at the border adopt the frame A and frame B together with a common phase clock reference, as recommended in ECC Recommendation (20)03.

In this context, the DL time slots to uplink time slots collision probability is 50% under condition of 100% fully loaded networks, as shown in Figure 25 below.

	Slot 0	Slot 1	Slot 2	Slot 3	Slot 4	Slot 5	Slot 6	Slot 7	Slot 8	Slot 9
DDDSU (10:2:2) +0ms	D	D	D	S	U	D	D	D	S	U
DDDSUUD DDD (6:4:4)	D	D	D	S	U	U	D	D	D	D

Figure 25: DL Time Slots to UL Time Slots collisions under fully loaded AAS network

ANNEX 2: SIMULATION RESULTS FOR SEPARATION DISTANCES vs TP LOSS

A2.1 INTRODUCTION

This Report addresses cross-border coordination for MFCN (including AAS BS and non-AAS BS) in the following operation modes:

- 1 Synchronised operation
- 2 Unsynchronised operation with partial duplex misalignment and ECC Recommendation (20)03 recommended scenario with Downlink Symbol Blanking (DSB)
- 3 Unsynchronised operation with partial duplex misalignment and ECC Recommendation (20)03 recommended scenario without DSB
- 4 Fully-unsynchronised operation (i.e. 100% duplex misalignment) without preferential frequency blocks
- 5 Fully-unsynchronised operation (i.e. 100% duplex misalignment) with preferential frequency blocks

This annex shows simulation results on the throughput loss corresponding to various separation distances D between the two networks for the operation modes 1, 4 and 5 above. For operation modes 2 and 3, the simulation results of fully-unsynchronised operation (operation mode 4) have been reused with some adjustments when deriving field strength values (see ANNEX 3 for more details).

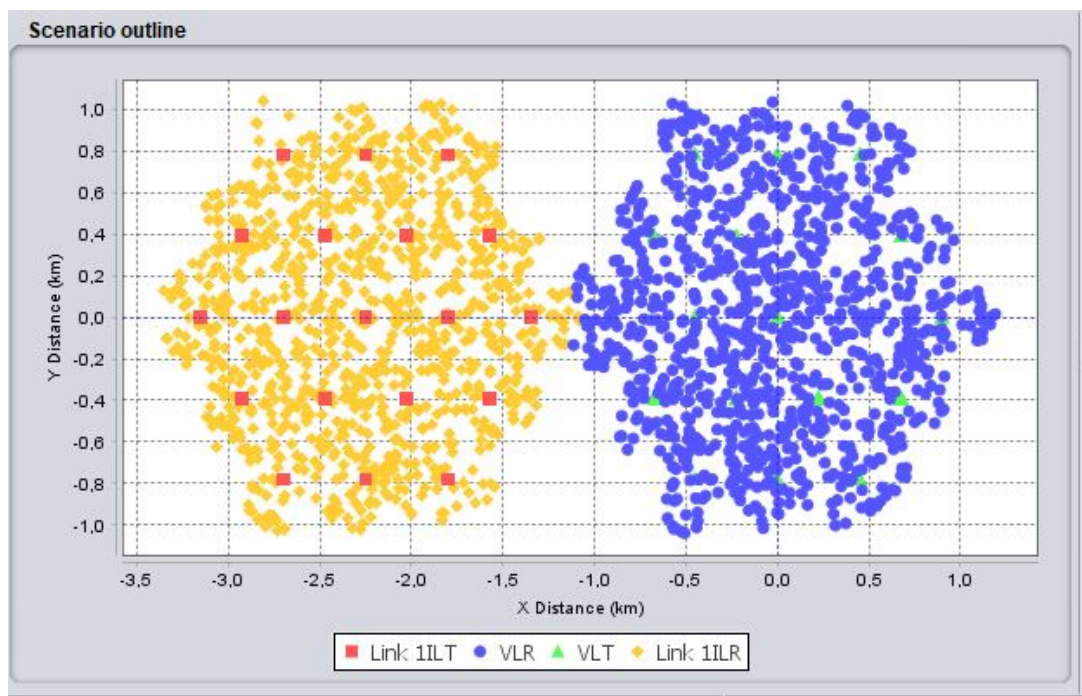

Figure 26: Simulation of interference from network A to network B (synchronised operation scenarios. For unsynchronised operation, an additional distance D between the two networks is implemented (not shown in the figure))

For synchronised operation, the coexistence criterion was a Network DL throughput loss below 5%, which is always achieved in all simulations performed (without any additional separation distance, i.e. $D = \text{cell_range} * 1.5$) and the distance to the borderline is assumed to be $D_x = \text{Cell range}$. For unsynchronised operation, the Network UL throughput loss was simulated for various distances D between the two BS at the edge of the network, with the aim to determine the value for D corresponding

to 10%, 20% and 30% Network UL throughput loss (which is then used in ANNEX 3 as a basis to derive the associated field strength levels at the border).

For all AAS-AAS cases, three different sets of simulations have been performed. The study 1 has been performed with the simulation tool SEAMCAT v5.4.1. The studies 2 and 3 have been performed using industry tools. In case of synchronised operations, all the results are below 5% DL loss. In case of unsynchronised operation, the average of the UL TP loss from the 3 studies is computed and an interpolation is performed in order to get the separation distance corresponding to 10%, 20% and 30% UL TP loss. For unsynchronised scenarios in Rural areas, both cell range of 4000 m and 1155 m have been simulated for comparison purposes. For all cases involving non-AAS, one single set of simulations has been performed using SEAMCAT v5.4.1 and no interpolation was performed.

A2.2 SIMULATION RESULTS

Table 12: Distance results for synchronised operation

AAS mode	Parameter	Suburban			Rural				
	Cell radius (m)	50	100	150	250	400	500	1000	2000
	Cell range (m)	100	200	300	500	800	1000	2000	4000
	D (m)	150	300	450	750	1200	1500	3000	6000
	SEAMCAT DeltaX (m)	450	900	1350	2250	3600	4500	9000	18000
AAS to AAS (study 1)	Ref. cell DL TP Loss	0.67%	0.74%	1.14%	0.86%		1.82%	1.57%	1.08%
	Average Network DL TP Loss	0.04%	0.05%	0.08%	0.05%		0.13%	0.13%	0.08%
	iRSS (dBm)	-62.2	-70.9	-75.1	-75		-81.7	-92.3	-104.8
AAS to AAS (study 2)	Average Network DL TP Loss		4%			3%			
AAS to AAS (study 3)	Average Network DL TP Loss	0.03%	0.04%	0.03%	0.03%		0.04%	0.03%	0.03%
AAS to Non-AAS	Ref. cell DL TP Loss	4.16%	5.45%	5.69%	6.03%		7.25%	7.57%	2.66%
	Average Network DL TP Loss	0.25%	0.41%	0.44%	0.54%		0.70%	0.60%	0.15%
	iRSS (dBm)	-60.22	-67.28	-71.86	-77.74		-84.7	-94.63	-107
Non-AAS to AAS	Ref. cell DL TP Loss	1.01%	1.54%	1.67%	0.89%		0.82%	0.85%	0.44%
	Average Network DL TP Loss	0.11%	0.11%	0.11%	0.07%		0.07%	0.06%	0.03%
	iRSS (dBm)	-41.82	-51.91	-59.91	-68.34		-79.9	-91.08	-103.51
Non-AAS to Non-AAS	Ref. cell DL TP Loss	21.92%	20.87%	14.16%	17.64%		13.21%	11.13%	3.09%
	Average Network DL TP Loss	2.28%	1.72%	1.11%	1.91%		1.26%	0.83%	0.17%
	iRSS (dBm)	-44.07	-54.38	-63.6	-68.63		-80.35	-91.48	-104.101

From the different simulations results in case of synchronised operations, all the results for suburban and rural environments are below 5% DL throughput loss.

Table 13: Distance results for unsynchronised operation in AAS to AAS cases

Fully unsynchronised (worst-case)	Suburban	Separation distance D (km)	0.45	2.7	3.6	4.5	7	10	15	20	25	30	35	40		
		iRSS unwanted (dBm)	-37.2	-55.1	-59.4	-62.7	-71.5	-79.6	-88.1	-94.7	-99.5	-103.8	-106.6	-109.1		
		Ref. Cell UL TP Loss	100%	99.31%	98.55%	98.03%	91.45%	74.50%	53.68%	34.98%	20.85%	11.13%	5.34%	2.81%		
		Average Network UL TP Loss	99.78%	98.62%	97.62%	96.12%	85.24%	68.86%	48.47%	31.71%	19.36%	11.11%	6.13%	3.79%		
	Rural (cell range 4000 m)	Separation distance D (km)	6	20	30	35	40	50	60	70	80	90	100			
		iRSS unwanted (dBm)	-58.90	-79.80	-87.1	-89.9	-92.3	-96.8	-100	-103	-104.7	-106.5	-107.9			
		Ref. Cell UL TP Loss	97.21%	69.27%	61.32%	56.75%	48.41%	31.58%	19.65%	12.71%	9.43%	9.41%	7.73%			
		Average Network UL TP Loss	75.20%	57.27%	43.20%	35.86%	29.09%	18.72%	13.70%	10.08%	7.99%	7.01%	6.12%			
	Rural (cell range 1155 m)	Separation distance D (km)	6	20	30	35	40	50	60	70	80	90	100			
		iRSS unwanted (dBm)	-56	-79.4	-87.8	-90.7	-93.4	-98.3	-102.3	-104.9	-107.2	-109.4	-110.9			
		Ref. Cell UL TP Loss	99.47%	77.42%	63.33%	55.09%	44.97%	25.21%	13.49%	8.60%	6.25%	3.49%	3.16%			
		Average Network UL TP Loss	95.94%	70.29%	54.94%	45.97%	37.97%	22.62%	13.65%	9.16%	6.65%	4.99%	4.02%			
	Suburban (study 2)	Separation distance D (km)	1	10	20	30	40	50								
		Average Network UL TP Loss	98.17%	59.63%	12.32%	6.42%	3.40%	1.91%								
	Rural (study 2)	Separation distance D (km)	10	20	30	40	50	60	70	80						
		Average Network UL TP Loss	99.40%	74.50%	36.80%	20.10%	12.40%	8.00%	5.40%	3.80%						
	Suburban (study 3)	Separation distance D (km)	0.45	2.7	3.6	4.5	7	10	15	20	25	30	35	40		
		Average Network UL TP Loss	98.14%	89.39%	85.19%	80.64%	62.36%	39.32%	22.69%	15.03%	9.73%	6.68%	4.97%	3.92%		
	Rural (study 3)	Separation distance D (km)	1	6	20	30	35	40	50	60	70	80	100			
		Average Network UL TP Loss	72.52%	60.62%	34.26%	24.34%	20.28%	17.00%	12.55%	9.94%	8.12%	6.66%	4.26%			
Suburban (average)	Separation distance D (km)	0.45	1	2.7	3.6	4.5	7	10	15	20	25	30	35	40	50	
	Study 1 UL TP Loss	99.78%		98.62%	97.62%	96.12%	85.24%	68.86%	48.47%	31.71%	19.36%	11.11%	6.13%	3.79%		

Table 14: Distance results for unsynchronised operation in AAS to Non-AAS cases and Non-AAS to AAS cases

Fully unsynchronised (worst-case)	Suburban AAS to Non-AAS	Separation distance D (km)	5	17	20	20.5	23	26.5	30	32	35	40	45	50	55		
		Ref. Cell UL TP Loss	100.00%	65.15%	49.87%	45.86%	35.13%	22.98%	14.94%	11.76%	8.19%	4.45%	2.78%	1.75%	1.21%		
		Net UL TP Loss	99.91%	59.77%	43.71%	40.00%	30.60%	19.90%	12.90%	10.18%	7.12%	3.90%	2.44%	1.54%	1.06%		
		iRSS unwanted (dBm)	-60	-86.11	-89.7	-90.4	-92.54	-95.8	-98.2	-99.5	-101.3	-104.2	-106.2	-108.3	-110.1		
	Suburban Non-AAS to AAS	Separation distance D (km)	5	10	15	20	22	25	26	30	35	38	40	50			
		Ref. Cell UL TP Loss	99.18%	87.15%	65.65%	49.58%	44.50%	35.88%	34.16%	22.26%	13.14%	8.91%	7.05%	2.11%			
		Average Network UL TP Loss	98.21%	81.47%	61.77%	45.75%	40.86%	32.81%	30.92%	20.86%	13.26%	9.85%	8.25%	3.45%			
		iRSS unwanted (dBm)	-59.72	-74.61	-83.69	-90.03	-91.91	-94.86	-95.35	-99.08	-101.51	-103.48	-104.39	-108.66			
	Rural AAS to Non-AAS	Separation distance D (km)	28	30	38	40	45	50	60	70	80	90	100				
		Ref. Cell UL TP Loss	83.00%	69.98%	54.46%	50.00%	42.52%	35.85%	22.70%	16.02%	8.06%	7.49%	7.15%				
		Average Network UL TP Loss	60.52%	41.24%	29.00%	26.06%	20.81%	16.19%	10.12%	6.95%	4.73%	3.56%	2.77%				
		iRSS unwanted (dBm)	-77.6	-86.1	-90.48	-91.7	-93.67	-95.6	-98.7	-101.2	-103.5	-105.1	-106.4				
	Rural Non-AAS to AAS	Separation distance D (km)	10	20	23	30	37	40	44	50	54	60	70	80	90	100	110
		Ref. Cell UL TP Loss	97.08%	76.51%	68.74%	65.49%	64.80%	56.70%	48.11%	35.68%	31.02%	24.14%	15.35%	13.24%	8.64%	9.08%	6.42%
		Average Network UL TP Loss	74.38%	63.78%	60.00%	50.74%	40.08%	35.11%	29.00%	22.40%	19.46%	15.52%	12.09%	10.04%	7.90%	7.06%	6.24%
		iRSS unwanted (dBm)	-64.91	-79.98	-81.25	-86.34	-89.83	-91.39	-93.08	-96.05	-97.06	-98.87	-101.92	-103.87	-105.89	-106.92	-108.51
Fully unsynchronised preferential frequencies	Suburban AAS to Non-AAS	Separation distance D (km)	2	3	3.5	4	4.4	5	5.5	6	7	10					
		Ref. Cell UL TP Loss	73.23%	57.25%	48.47%	39.69%	31.61%	23.38%	18.44%	13.77%	7.07%	1.38%					
		Average Network UL TP Loss	56.75%	38.56%	30.59%	24.01%	19.10%	13.31%	10.42%	7.72%	4.07%	0.86%					
		iRSS unwanted (dBm)	-86.2	-92.3	-94.38	-96.3	-98.1	-100.2	-101.77	-103.4	-106.8	-114.2					
	iRSS blocking (dBm)	-82.7	-88.8	-90.91	-92.9	-94.63	-97.7	-98.3	-100	-103.3	-110.7						
	Suburban Non-AAS to AAS	Separation distance D (km)	1.7	2	2.3	3	4	5	6	7.5	10						
		Ref. Cell UL TP Loss	52.89%	48.66%	41.05%	20.06%	8.77%	4.31%	2.00%	0.78%	0.20%						
		Average Network UL TP Loss	30.04	24.338	19.30%	11.43%	5.71%	2.80%	1.44%	0.58%	0.16%						
iRSS unwanted (dBm)		-92.38	-94.5	-96.67	-100.5	-105.5	-109.3	-113.3	-117.8	-124.1							

		iRSS blocking (dBm)	-86.13	-88.2	-90.42	-94.3	-99.3	-103.1	-107	-111.5	-117.9							
	Rural AAS to Non-AAS	Separation distance D (km)	2	4	6	10												
		Ref. Cell UL TP Loss	72.74%	49.29%	30.23%	10.82%												
		Average Network UL TP Loss	7.98%	4.95%	2.79%	0.87%												
		iRSS unwanted (dBm)	-88.9	-95.9	-102.3	-100												
		iRSS blocking (dBm)	-85.4	-92.5	-98.8	-106.5												
	Rural Non-AAS to AAS	Separation distance D (km)	1	2	6	10												
		Ref. Cell UL TP Loss	69.65%	65.56%	26.50%	6.56%												
		Average Network UL TP Loss	8.96%	7.35%	2.70%	0.79%												
		iRSS unwanted (dBm)	-81.9	-87.5	-102.5	-113												
iRSS blocking (dBm)		-75.6	-81.2	-96.2	-106.8													
Unsyncronised operation based on ECC Recommendation (20)03 (partial duplex misalignment) without DSB	Suburban AAS to Non-AAS	Separation distance D (km)	5	17	20	20.5	23	26.5	30	32	35	40	45	50	55			
		Ref. Cell UL TP Loss	50.00%	32.58%	24.94%	22.93%	17.57%	11.49%	7.47%	5.88%	4.10%	2.22%	1.39%	0.88%	0.60%			
		Average Network UL TP Loss	49.96%	29.89%	21.85%	20.00%	15.30%	9.95%	6.45%	5.09%	3.56%	1.95%	1.22%	0.77%	0.53%			
	Suburban Non-AAS to AAS	Separation distance D (km)	5	10	15	20	22	25	26	30	35	38						
		Ref. Cell UL TP Loss	49.59%	43.58%	32.83%	24.79%	22.25%	17.94%	17.08%	11.13%	6.57%	4.46%						
		Average Network UL TP Loss	49.11%	40.74%	30.89%	22.88%	20.43%	16.41%	15.46%	10.43%	6.63%	4.93%						
	Rural AAS to Non-AAS	Separation distance D (km)	28	30	38	40	45	50	60	70	80	90						
		Ref. Cell UL TP Loss	41.50%	34.99%	27.23%	25.00%	21.26%	17.92%	11.35%	8.01%	4.03%	3.75%						
		Average Network UL TP Loss	30.26%	20.62%	14.50%	13.03%	10.41%	8.09%	5.06%	3.47%	2.37%	1.78%						
	Rural Non-AAS to AAS	Separation distance D (km)	10	20	23	30	37	40	44	50	54	60	70	80	90	100	110	
		Ref. Cell UL TP Loss	48.54%	38.26%	34.37%	32.75%	32.40%	28.35%	24.06%	17.84%	15.51%	12.07%	7.68%	6.62%	4.32%	4.54%	3.21%	
		Average Network UL TP Loss	37.19%	31.89%	30.00%	25.37%	20.04%	17.56%	14.50%	11.20%	9.73%	7.76%	6.05%	5.02%	3.95%	3.53%	3.12%	

ANNEX 3: FIELD STRENGTH VALUES

The relation between field strength E (dB μ V/m) and power level Pr (dBm) can be expressed as

$$E = Pr + 20 * \log_{10} F + 77.2 \quad (1)$$

Where:

- F is the frequency in MHz.

$$Pr = Ptx + G1 - PL \quad (2)$$

Where:

- Pr is the received power level at the receiving antenna;
- Ptx is the transmit power before antenna;
- $G1$ is interfering BS antenna gain including array ohmic loss in the direction of the receiving antenna;
- PL is the pathloss at the distance Dx (, where Dx is the distance between the transmitting BS and the borderline).

For synchronised cases, $Dx = \text{cell_range} = \text{cell_radius} * 2$, where D is the distance between the transmitting BS and the victim BS. For unsynchronised cases without DSB, a shared exclusion area is assumed and therefore $Dx = D/2$, using the relevant values for D in ANNEX 2. For the DSB implementation zone, $Dx = D$.

With AAS antenna data traffic channel beamforming, $G1$ is a variable parameter, the median data traffic channel power level Pr_median is simulated with SEAMCAT using a single transmitting BS and a receiving antenna located at borderline (i.e. distance Dx instead of D for unsynchronised cases without DSB) and an omnidirectional antenna with 0 dBi antenna gain at 3 m antenna height.

Pr_max is calculated using MCL method taking into consideration the maximum antenna gain (as identified in ANNEX 1, i.e. with the assumption of AAS BS main beam with the maximum antenna gain permanently pointing to the borderline) and location at borderline i.e. at distance Dx from the transmitting BS. This value represents the maximum possible FS in border area. The simulated median FS value can be used as a candidate trigger value but the calculated maximum FS value is an upper-bound for information. SSB field strength is calculated using MCL method taking into consideration the relevant antenna gain for single-beam and multi-beam cases (as identified in Annex 1) and location at borderline i.e. at the distance Dx from the transmitting BS.

For operation mode #3 ("Unsynchronised operation with partial duplex misalignment and ECC Recommendation (20)03 [2] recommended scenario without DSB"), the simulation results of fully-unsynchronised operation (operation mode 4) have been reused with a scaling factor of 0.5 on the UL throughput loss considering the partial duplex misalignment.

For operation mode #2 i.e. when Downlink Symbol Blanking (DSB) is applied to both networks across the borderline in a sufficient area ("DSB implementation zone"), there is no more collision from downlink time slots to uplink time slots. The remaining interference is from Downlink to Downlink, therefore the field strength values for synchronised operation could apply to BS implementing and activating DSB.. The activation of DSB is determined using an agreed field strength value, which is derived from results for operation mode #3 ("Unsynchronised operation with partial duplex misalignment and ECC Recommendation (20)03 recommended scenario without DSB"), by choosing $Dx = D$ (instead of $D/2$) since victim BS activating DSB can be deployed at the border. This field strength value applies to BS transmitting from outside the DSB implementation zone.

Table 15: Field strength results at borderline at 3 m for unsynchronised operation in AAS to AAS scenarios

	Scenario	Fully unsynchronised (worst-case)						Fully unsynchronised with preferential freq			Unsynchronised operation based on ECC Rec (20)03 (partial duplex misalignment) without DSB						Unsynchronised operation based on ECC Rec (20)03 (partial duplex misalignment) with DSB For DSB implementation zone					
		Suburban			Rural			Suburban			Suburban			Rural			Suburban			Rural		
		10%	20%	30%	10%	20%	30%	10%	20%	30%	10%	20%	30%	10%	20%	30%	10%	20%	30%	10%	20%	30%
	BS antenna downtilt	6	6	6	3	3	3	6	6	6	6	6	6	3	3	3	6	6	6	3	3	3
	Hbs-Hrx (m)	22	22	22	32	32	32	22	22	22	22	22	22	32	32	32	22	22	22	32	32	32
	Distance to victim D (km)	28.51	19.90	16.76	64.22	46.38	37.52	4.00	2.63	1.96	19.90	13.91	9.32	46.38	29.91	19.77	19.90	13.91	9.32	46.38	29.91	19.77
	Distance to borderline Dx (km)	14.26	9.95	8.38	32.11	23.19	18.76	2.00	1.32	0.98	9.95	6.96	4.66	23.19	14.95	9.89	19.90	13.91	9.32	46.38	29.91	19.77
	PL (dB)	185.90	177.20	173.20	192.90	184.50	179.20	145.80	139.50	135.00	177.20	168.90	160.50	184.50	173.60	163.60	194.32	185.40	175.70	202.85	191.10	180.56
	Vertical angle (0°)	0.09	0.13	0.15	0.06	0.08	0.10	0.63	0.96	1.29	0.13	0.18	0.27	0.08	0.12	0.19	0.06	0.09	0.14	0.04	0.06	0.09
	Vertical angle (0°) - tilt	-5.91	-5.87	-5.85	-2.94	-2.92	-2.90	-5.37	-5.04	-4.71	-5.87	-5.82	-5.73	-2.92	-2.88	-2.81	-5.94	-5.91	-5.86	-2.96	-2.94	-2.91
E_data	Pr_median (dBm/(80 MHz))	-140.70	-131.80	-127.70	-134.10	-125.80	-120.40	-99.10	-91.90	-86.70	-131.70	-123.20	-114.80	-125.70	-114.70	-104.80	-149.08	-140.09	-130.12	-144.11	-132.25	-121.75
	E_median (dBµV/m/(5 MHz))	-4.41	4.49	8.59	2.19	10.49	15.89	37.19	44.39	49.59	4.59	13.09	21.49	10.59	21.59	31.49	-12.79	-3.80	6.17	-7.82	4.04	14.54
	Pr_max (dBm/(80 MHz))	-110.64	-101.94	-97.94	-117.64	-109.24	-103.94	-70.54	-64.24	-59.74	-101.94	-93.64	-85.24	-109.24	-98.34	-88.34	-119.06	-110.14	-100.44	-127.59	-115.84	-105.30
	E_max (dBµV/m/(5 MHz))	25.65	34.35	38.35	18.65	27.05	32.35	65.75	72.05	76.55	34.35	42.65	51.05	27.05	37.95	47.95	17.23	26.15	35.85	8.70	20.45	30.99
SSB single-beam	Vertical ant, Gain loss (dB)	5.82	5.75	5.70	1.50	1.48	1.46	4.79	4.17	3.67	5.75	5.65	5.48	1.48	1.44	1.40	5.87	5.82	5.73	1.51	1.49	1.47
	GTx (dB)	11.18	11.25	11.30	15.50	15.52	15.54	12.21	12.83	13.33	11.25	11.35	11.52	15.52	15.56	15.60	11.13	11.18	11.27	15.49	15.51	15.53
	Pr (dBm/(30 kHz))	-157.72	-148.95	-144.90	-160.40	-151.98	-146.66	-116.59	-109.67	-104.67	-148.95	-140.55	-131.98	-151.98	-141.04	-131.00	-166.19	-157.22	-147.43	-170.36	-158.59	-148.03
	E_SSB (dBµV/m/(30 kHz))	-9.39	-0.61	3.43	-12.06	-3.64	1.67	31.74	38.67	43.66	-0.61	7.79	16.36	-3.64	7.29	17.34	-17.85	-8.88	0.90	-22.02	-10.26	0.31
SSB Multi-beam	Vertical ant, Gain loss (dB)	16.51	16.22	16.04	2.75	2.72	2.69	12.41	9.93	8.42	16.22	15.81	15.13	2.72	2.64	2.54	16.70	16.49	16.16	2.78	2.75	2.69
	GTx (dB)	7.49	7.78	7.96	21.25	21.28	21.31	11.59	14.07	15.58	7.78	8.19	8.87	21.28	21.36	21.46	7.30	7.51	7.84	21.22	21.25	21.31
	Pr (dBm/30 kHz)	-161.41	-152.42	-148.24	-154.65	-146.22	-140.89	-117.21	-108.43	-102.42	-152.42	-143.71	-134.63	-146.22	-135.24	-125.14	-170.02	-160.89	-150.86	-164.63	-152.85	-142.25
	E_SSB (dBµV/m/(30 kHz))	-13.08	-4.09	0.09	-6.32	2.12	7.45	31.13	39.91	45.91	-4.09	4.63	13.70	2.12	13.09	23.20	-21.69	-12.56	-2.52	-16.30	-4.51	6.08

Table 16: Field strength results at borderline at 3 m for unsynchronised operation in AAS to non-AAS scenarios

	Scenario	Fully unsynchronised (worst-case)						Fully unsynchronised with preferential freq			Unsynchronised operation based on ECC Rec (20)03 (partial duplex misalignment) without DSB						Unsynchronised operation based on ECC Rec (20)03 (partial duplex misalignment) with DSB For DSB implementation zone					
		Suburban			Rural			Suburban			Suburban			Rural			Suburban			Rural		
		10%	20%	30%	10%	20%	30%	10%	20%	30%	10%	20%	30%	10%	20%	30%	10%	20%	30%	10%	20%	30%
	BS antenna downtilt	6	6	6	3	3	3	6	6	6	6	6	6	3	3	3	6	6	6	3	3	3
	Hbs-Hrx (m)	22	22	22	32	32	32	22	22	22	22	22	22	32	32	32	22	22	22	32	32	32
	Distance to victim D (km)	32	26.5	23	60	45	38	5.5	4.4	3.5	26.5	20.5	17	45	30	28	26.5	20.5	17	45	30	28
	Distance to borderline Dx (km)	16	13.25	11.5	30	22.5	19	2.75	2.2	1.75	13.25	10.25	8.5	22.5	15	14	26.5	20.5	17	45	30	28
	PL (dB)	188.87	184.21	180.74	191.18	183.83	179.56	150.99	147.36	143.81	184.21	177.96	173.53	183.83	173.68	171.99	201.50	195.06	190.38	202.10	191.18	189.41
	Vertical angle (0°)	0.08	0.10	0.11	0.06	0.08	0.10	0.46	0.57	0.72	0.10	0.12	0.15	0.08	0.12	0.13	0.05	0.06	0.07	0.04	0.06	0.07
	Vertical angle (0°) - tilt	-5.92	-5.90	-5.89	-2.94	-2.92	-2.90	-5.54	-5.43	-5.28	-5.90	-5.88	-5.85	-2.92	-2.88	-2.87	-5.95	-5.94	-5.93	-2.96	-2.94	-2.93
E_data	Pr_median (dBm/(80 MHz))	-143.51	-138.92	-135.47	-132.25	-125.03	-120.75	-104.60	-100.80	-96.82	-138.92	-132.65	-128.16	-125.03	-114.76	-113.27	-156.21	-149.85	-145.11	-143.14	-132.35	-130.75
	E_median (dBµV/m/(5 MHz))	-7.22	-2.63	0.82	4.04	11.26	15.54	31.69	35.49	39.47	-2.63	3.64	8.13	11.26	21.53	23.02	-19.92	-13.56	-8.82	-6.85	3.94	5.54
	Pr_max (dBm/(80 MHz))	-113.61	-108.95	-105.48	-115.92	-108.57	-104.30	-75.73	-72.10	-68.55	-108.95	-102.70	-98.27	-108.57	-98.42	-96.73	-126.24	-119.80	-115.12	-126.84	-115.92	-114.15
	E_max (dBµV/m/(5 MHz))	22.68	27.34	30.81	20.37	27.72	31.99	60.56	64.19	67.74	27.34	33.59	38.02	27.72	37.87	39.56	10.05	16.49	21.17	9.45	20.37	22.14
SSB single beam	Vertical ant, Gain loss (dB)	5.84	5.81	5.78	1.49	1.48	1.46	5.12	4.90	4.62	5.81	5.76	5.71	1.48	1.44	1.44	5.90	5.87	5.85	1.51	1.49	1.49
	GTx (dB)	11.16	11.19	11.22	15.51	15.52	15.54	11.88	12.10	12.38	11.19	11.24	11.29	15.52	15.56	15.56	11.10	11.13	11.15	15.49	15.51	15.51
	Pr (dBm/(30 kHz))	-160.71	-156.02	-152.52	-158.67	-151.31	-147.02	-122.11	-118.26	-114.43	-156.02	-149.72	-145.24	-151.31	-141.12	-139.43	-173.40	-166.93	-162.23	-169.61	-158.67	-156.90
	E_SSB (dBµV/m/(30 kHz))	-12.37	-7.68	-4.19	-10.34	-2.97	1.31	26.23	30.07	33.90	-7.68	-1.38	3.10	-2.97	7.21	8.91	-25.06	-18.60	-13.89	-21.27	-10.34	-8.56
SSB Multi-beam	Vertical ant, Gain loss (dB)	16.58	16.46	16.35	2.75	2.71	2.69	13.71	12.84	11.73	16.46	16.25	16.06	2.71	2.65	2.63	16.82	16.72	16.62	2.78	2.75	2.74
	GTx (dB)	7.42	7.54	7.65	21.25	21.29	21.31	10.29	11.16	12.27	7.54	7.75	7.94	21.29	21.35	21.37	7.18	7.28	7.38	21.22	21.25	21.26
	Pr (dBm/30 kHz)	-164.45	-159.67	-156.09	-152.93	-145.54	-141.25	-123.70	-119.20	-114.54	-159.67	-153.21	-148.59	-145.54	-135.33	-133.62	-177.32	-170.78	-166.00	-163.88	-152.93	-151.15
	E_SSB (dBµV/m/(30 kHz))	-16.12	-11.33	-7.75	-4.59	2.79	7.09	24.64	29.14	33.80	-11.33	-4.87	-0.25	2.79	13.01	14.72	-28.98	-22.44	-17.66	-15.54	-4.59	-2.81

Table 17: Field strength results at borderline at 3 m for unsynchronised operation in non-AAS to AAS scenarios

Scenario	Fully unsynchronised (worst-case)						Fully unsynchronised with preferential freq			Unsynchronised operation based on rec (20)03 (partial duplex misalignment) without DSB						Unsynchronised operation based on Rec (20)03 (partial duplex misalignment) with DSB For DSB implementation zone					
	Suburban			Rural			Suburban			Suburban			Rural			Suburban			Rural		
Environment	10%	20%	30%	10%	20%	30%	10%	20%	30%	10%	20%	30%	10%	20%	30%	10%	20%	30%	10%	20%	30%
UL TP Loss(%)	10%	20%	30%	10%	20%	30%	10%	20%	30%	10%	20%	30%	10%	20%	30%	10%	20%	30%	10%	20%	30%
BS antenna downtilt	6	6	6	3	3	3	6	6	6	6	6	6	3	3	3	6	6	6	3	3	3
Hbs-Hrx (m)	22	22	22	32	32	32	22	22	22	22	22	22	32	32	32	22	22	22	32	32	32
Distance to victim D (km)	38	30	26	80	54	44	3	2.3	1.7	30	22	15	54	37	23	30	22	15	54	37	23
Distance to borderline Dx (km)	19	15	13	40	27	22	1.5	1.15	0.85	15	11	7.5	27	18.5	11.5	30	22	15	54	37	23
PL	193.06	187.58	184.21	196.17	187.48	182.89	141.63	137.59	132.37	187.58	180.23	171.25	187.48	178.94	167.75	203.27	196.36	187.58	202.84	194.45	183.89
Vertical angle (0°)	0.07	0.08	0.10	0.05	0.07	0.08	0.84	1.10	1.48	0.08	0.11	0.17	0.07	0.10	0.16	0.04	0.06	0.08	0.03	0.05	0.08
Vertical angle (0°) - tilt	-5.93	-5.92	-5.90	-2.95	-2.93	-2.92	-5.16	-4.90	-4.52	-5.92	-5.89	-5.83	-2.93	-2.90	-2.84	-5.96	-5.94	-5.92	-2.97	-2.95	-2.92
F.1336 vertical gain loss	7.31	7.31	7.31	1.89	1.77	1.77	5.68	5.04	4.25	7.31	7.31	7.07	1.77	1.77	1.65	7.56	7.31	7.31	1.89	1.89	1.77
Pr (dBm/(20 MHz))	-136.37	-130.89	-127.52	-134.06	-125.25	-120.66	-83.31	-78.63	-72.62	-130.89	-123.54	-114.32	-125.25	-116.71	-105.40	-146.83	-139.67	-130.89	-140.73	-132.34	-121.66
E (dBµV/m/(5 MHz))	5.94	11.42	14.79	8.26	17.07	21.66	59.01	63.68	69.69	11.42	18.77	28.00	17.07	25.61	36.92	-4.52	2.64	11.42	1.59	9.98	20.66

Table 18: Field strength results for synchronised operation in all scenarios at borderline at 3 m

	Scenario	AAS to AAS							AAS to Non-AAS					Non-AAS to AAS	
		Suburban			Rural				Suburban			Rural		Suburban	Rural
	BS antenna downtilt	6	6	6	3	3	3	3	6	6	6	3	3	6	3
	Hbs-Hrx (m)	22	22	22	32	32	32	32	22	22	22	32	32	22	32
	Distance to victim D (km)	0.10	0.20	0.30	0.50	1.00	2.00	4.00	0.15	0.3	0.45	3	6	0.45	6
	Distance to borderline Dx (km)	0.10	0.20	0.30	0.50	1.00	2.00	4.00	0.15	0.3	0.45	3	6	0.45	6
	PL	88.56	100.70	112.50	113.50	119.49	129.43	140.36	99.55	112.59	120.27	140.56	152.81	120.27	152.81
	Vertical angle (0°)	12.41	6.28	4.19	3.66	1.83	0.92	0.46	8.34	4.19	2.80	0.61	0.31	2.80	0.31
	Vertical angle (0°) - tilt	6.41	0.28	-1.81	0.66	-1.17	-2.08	-2.54	2.34	-1.81	-3.20	-2.39	-2.69	-3.20	-2.69
E_data	Pr_median (dBm/(80 MHz))	-46.80	-54.40	-58.30	-57.50	-66.40	-75.60	-86.30	-42.37	-58.70	-68.64	-81.60	-93.84		
	E_median (dBµV/m/(5 MHz))	89.49	81.89	77.99	78.79	69.89	60.69	49.99	93.92	77.59	67.65	54.69	42.45		
	Pr_max (dBm/(80 MHz))	-13.30	-25.44	-37.24	-38.24	-44.23	-54.17	-65.10	-24.29	-37.33	-45.01	-65.30	-77.55		
	E_max (dBµV/m/(5 MHz))	122.99	110.85	99.05	98.05	92.06	82.12	71.19	112.00	98.96	91.28	70.99	58.74		
SSB single-beam	Vertical ant, Gain loss (dB)	4.60	0.00	0.63	0.00	0.04	0.28	0.51	0.41	0.66	1.76	1.06	1.30		
	GTx (dB)	12.40	17.00	16.37	17.00	16.96	16.72	16.49	16.59	16.34	15.24	15.94	15.70		
	Pr (dBm/(30 kHz))	-59.16	-66.70	-79.13	-79.50	-85.53	-95.71	-106.87	-65.96	-79.25	-88.03	-107.62	-120.11		
	E_SSB (dBµV/m/(30 kHz))	89.17	81.64	69.20	68.84	62.81	52.63	41.47	82.38	69.09	60.31	40.71	28.22		
SSB Multi-beam	Vertical ant, Gain loss (dB)	3.98	0.09	1.01	0.23	0.43	1.33	2.09	1.90	1.01	3.38	1.84	2.34		
	GTx (dB)	20.02	23.91	22.99	23.77	23.57	22.67	21.91	22.10	22.99	20.62	22.16	21.66		
	Pr (dBm/(30 kHz))	-51.54	-59.79	-72.51	-72.73	-78.92	-89.76	-101.45	-60.45	-72.60	-82.65	-101.40	-114.15		
	E_SSB (dBµV/m/(30 kHz))	96.80	88.54	75.82	75.61	69.42	58.58	46.89	87.88	75.73	65.69	46.94	34.18		
Non-AAS	F.1336 vertical gain loss													2.15	1.53
	Pr (dBm/(20 MHz))													-58.42	-90.34
	E (dBµV/m/(5 MHz))													83.89	51.97

ANNEX 4: EXAMPLE OF A CONVERSION FORMULA FROM SSB POWER LEVEL TO THE MAXIMUM DATA FIELD STRENGTH

At the time of writing this Report, AAS 5G NR BS in standalone mode is not available - the NR network is linked to the 4G existing core network. The difficulty of cross-border measurements in 5G is to evaluate the field strength value of the payload.

A similar approach than the one used for LTE measurements (CRS-RSRP) could be applied with, in addition, the variation of the antenna gain due to the beamforming.

In LTE, the measurements are done for the Cell Reference Signal Received Power, CRS-RSRP, in case of NR, the signal measure is the Synchronisation Signal Reference Signal Received Power, SS-RSRP. It is defined as the linear average over the power contributions of the resource elements that carry Secondary Synchronisation Signal, SSS.

In absence of traffic, the base station transmits only signalling information. The synchronisation signal block (SSB) is part of signalling, its occupancy is 20 RB, in 3.5 GHz with an SCS of 30 kHz, which is equal to a bandwidth of 7.2 MHz and is mainly located in the centre frequency of the band.

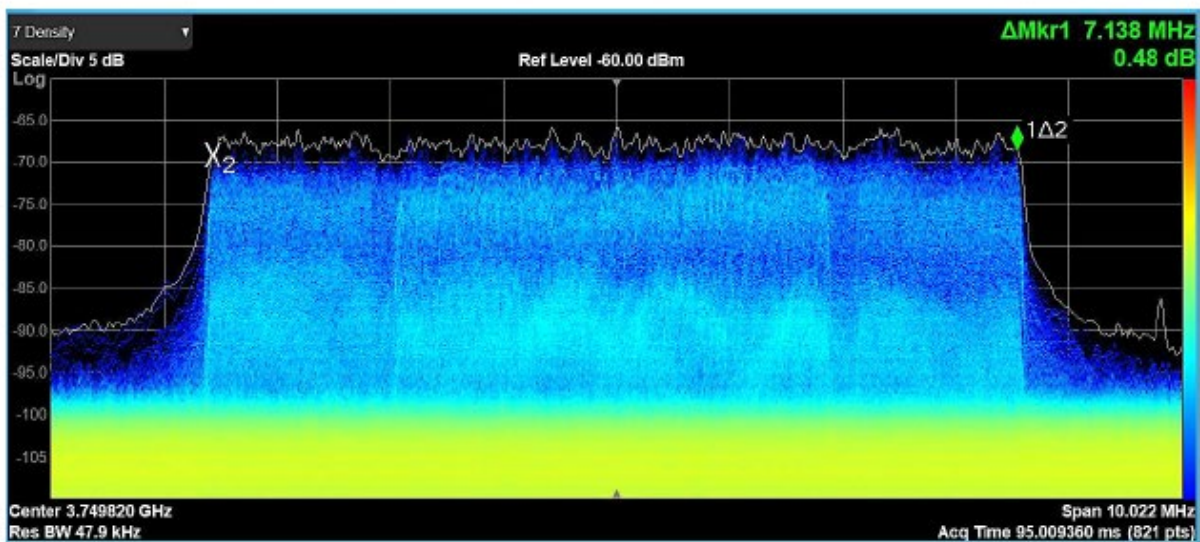

Figure 27: 7.2 MHz SSB spectrum

Spectral analyses provide more information in order to identify the number of SSBs (a block is related to one beam). The frame structure is 10 ms duration, and each SSB is transmitted for 20 ms. Depending on the antenna type, it is possible to have from 1 to 8 blocks (beams).

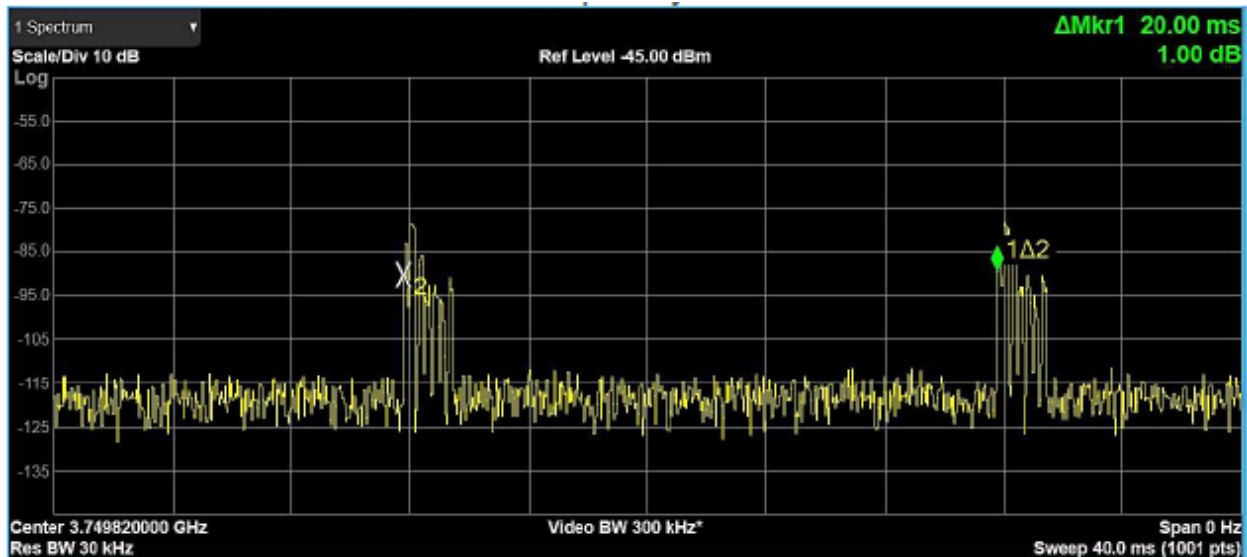

Figure 28: Temporal analysis over 40 ms

With smaller window duration, it is possible to identify the number of SSBs transmitted. On the following picture, 7 SSBs can be identified:

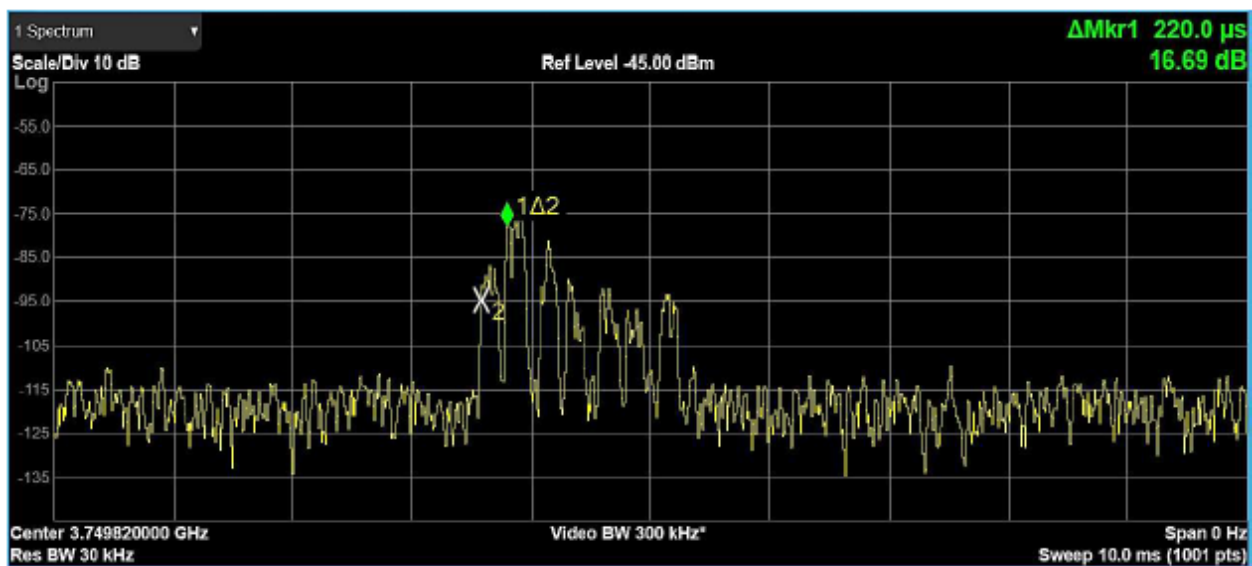

Figure 29: Identification of the 7 SSB

A4.1 METHODOLOGY TO CONVERT SSB MEASUREMENTS INTO DATA FIELD STRENGTH VALUE

The following section provides a methodology in order to extrapolate from the measured SS-RSRP, the maximum data field strength level when a BS is serving a single UE.

Depending on the equipment used during the measurements, it is also possible to identify the PCI code associated to SSB. The following figure represents the SSB signals and the associated PCI. The values are in decreasing order of SS-RSRP received.

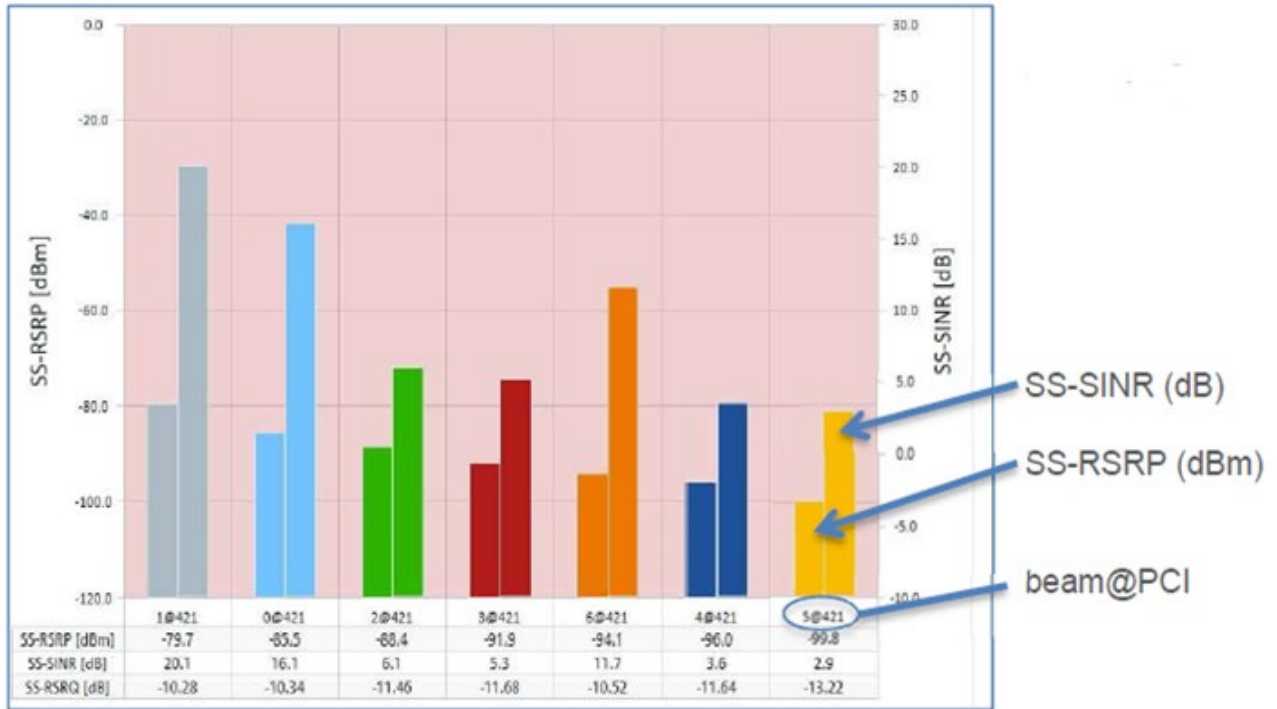

Figure 30: SSB measurements, 7 blocks

The measured SS-RSRP value depends on the subcarrier spacing (SCS) of the frame structure. In this example SCS is 30 kHz.

$$SS_RSRP(dB\mu V/m/(30\text{ kHz})) = SS_RSRP\text{ (dBm)} + AF\text{ (dB/m)} + \text{feeder loss (dB)} + 107, \quad (3)$$

for R = 50 Ω

Where:

AF is the antenna factor and depends on the frequency and antenna gain used for the measurements:

$$AF\text{ (dB/m)} = 20 \log_{10}(F_c\text{ in MHz}) - 29.8 - G\text{ (dBi)} \quad (4)$$

Therefore:

$$SS_RSRP(dB\mu V/m/(30\text{ kHz})) = SS_RSRP\text{ (dBm)} + 20 \log_{10}(F_c\text{ in MHz}) - G\text{ (dBi)} + \text{feeder loss (dB)} + 77.2 \quad (5)$$

For example, if:

- Centre frequency , Fc: 3749 MHz;
- Antenna gain used for the measurements, G: 5 dBi;
- Feeder loss : 2 dB.

$$SS_RSRP\text{ (dB}\mu V/m/(30\text{ kHz})) = SS_RSRP\text{ (dBm)} + 145.7 \quad (6)$$

The maximum field strength value for the data traffic when a BS is serving a single UE could be calculated as follows:

$$E(dB\mu V/m/(5\text{ MHz})) = SS_RSRP(dB\mu V/m) + 10 \log_{10}(5000/(30\text{ kHz})) + \Delta SSB, \text{ for an SCS of 30 kHz} \quad (7)$$

Where:

- ΔSSB represents the difference between the maximum antenna gain for the data traffic and the SSB antenna gain:

$$\Delta\text{SSB} = G_{\text{Data_antenna}} - G_{\text{SSB_antenna}} \quad (8)$$

$$\begin{aligned} E_{\text{data}}(\text{dB}\mu\text{V}/\text{m}/(5 \text{ MHz})) &= SS_RSRP(\text{dB}\mu\text{V}/\text{m}/(30 \text{ kHz})) + 22.2 \text{ dB} + \Delta\text{SSB} \\ &= SS_RSRP(\text{dBm}) + 167.9 + \Delta\text{SSB} \end{aligned} \quad (9)$$

It should be noted that within CEPT countries, there are two types of AAS BS, with a single fixed beam or with beam sweeping (from 2 to 8 blocks in 3600 MHz).

Table 19: Existing AAS BS type 1 and type 2, for AAS BS with 8x8 elements

Parameter	AAS BS type 1 (fixed SSB)	AAS BS Type 2 (beam sweeping)
G maxData antenna	24 dBi	25 dBi
G maxSSB antenna	17 dBi	24 dBi
Delta antenna gain, ΔSSB min	Min. 7 dB	Min. 1 dB

In this example, base station type 2 was measured with 7 SSBs, so $\Delta\text{SSB} = 1$ dB.

The table below summarises the maximum data field strength extrapolated from the SSB measurements in border area from SSB #0 to SSB #6:

Table 20: Extrapolation from SSB measurements

SSB #	0	1	2	3	4	5	6
SS-RSRP (dBm)	-85.5	-79.7	-88.4	-91.9	-96	-99.8	-94.1
Edata (dB μ V/m/(5 MHz))	83.4	89.2	80.5	77.0	72.9	69.1	74.8

Depending on the coordination threshold agreed between neighbouring administrations or operators, it is therefore possible to identify if the level is exceeded in border areas.

A4.2 CONCLUSION

This annex provides an example of conversion formula from SSB power level to the maximum data channel field strength level, as follows, considering a BS is serving a single UE:

$$\begin{aligned} E_{\text{data}}(\text{dB}\mu\text{V}/\text{m}/(5 \text{ MHz})) & \\ &= SS_RSRP(\text{dBm}) + 20 \log_{10}(F_c \text{ in MHz}) + 77.2 - G(\text{dBi}) + \text{feeder loss}(\text{dB}) \\ &\quad + 10 \log_{10}(5000/SCS) + \Delta\text{SSB} \end{aligned} \quad (10)$$

Where:

- G is the antenna gain of the test equipment;
- Feeder loss is the feeder loss between the receiving antenna and the test equipment;
- $\Delta\text{SSB} = \text{Data channel antenna gain} - \text{SSB antenna gain}$.

By considering that the dynamic moving behaviour of the data channel AAS BS main beam and the SSB antenna pattern (horizontal and vertical patterns) are unknown, in consequence Δ SSB related to the SS-RSRP is unknown.

The difference between the Maximum Data channel antenna gain G_{max_data} and the maximum SSB antenna gain G_{max_SSB} is known:

$$\Delta SSB_{max} = G_{max_data} - G_{max_SSB} \tag{11}$$

Using this Δ SSB_max, the maximum data channel field strength level (corresponding to the maximum data channel antenna gain direction) can be derived from the measured maximum SSB signal power level (corresponding the maximum SSB maximum antenna gain direction) as

$$\begin{aligned} E_{data_max} (dB\mu V/m/(5 MHz)) & \tag{12} \\ & = SS_RSRP_max(dBm) + 20\log_{10}(Fc \text{ in MHz}) + 77.2 - G (dBi) \\ & + feeder \text{ loss (dB)} + 10 \log_{10} (5000/SCS) + \Delta SSB_{max} \end{aligned}$$

This method has been developed taking into consideration the maximum SSB antenna gain, which intends to minimise the interference (with a real value of Δ SSB) in Measurement Point 2 as shown in Figure 31 below.

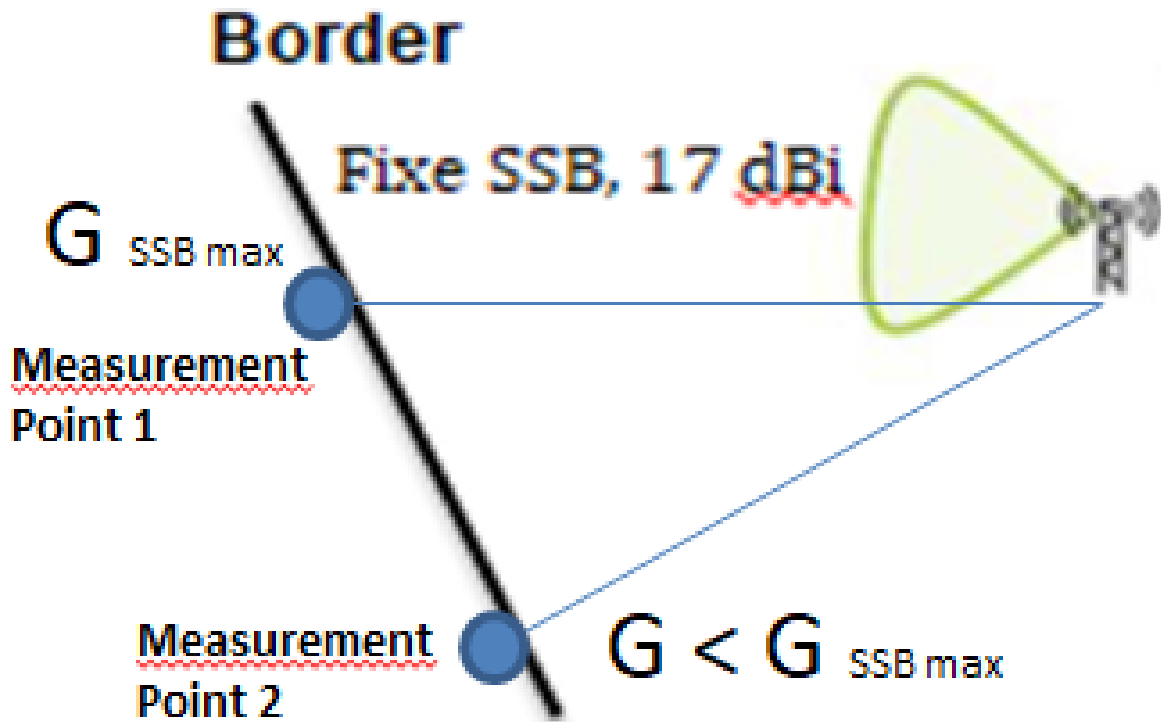

Figure 31: Example of measurements

ANNEX 5: CROSS-BORDER FIELD TEST RESULTS

A5.1 INTRODUCTION

Two frame structures are recommended in ECC Recommendation (20)03 [2]:

- 1 Frame A: DDDSU (format 4:1)
- 2 Frame B: DDDDDDSUU/DDDSUDDDD + 3 ms (format 8:2)

In order to test the performance degradation caused by using different frames, these two frames A and B have been implemented on different sites in a medium-size French city to measure the UL and DL throughput loss.

A5.2 FIELD TEST DESCRIPTION

The field test configuration is illustrated in Figure 32. The test configuration was characterised by seven sites:

- 1 A single isolated site (Site A) at the top of a hill (~120 m) using the DDDSU frame format (Frame A). Site A has an e.i.r.p. of 78 dBm with 90° azimuth and is fully loaded.
- 2 Six sites (Sites B) in the city using the DDDSUDDDD + 3 ms frame format (Frame B)

These seven sites had a common phase clock reference.

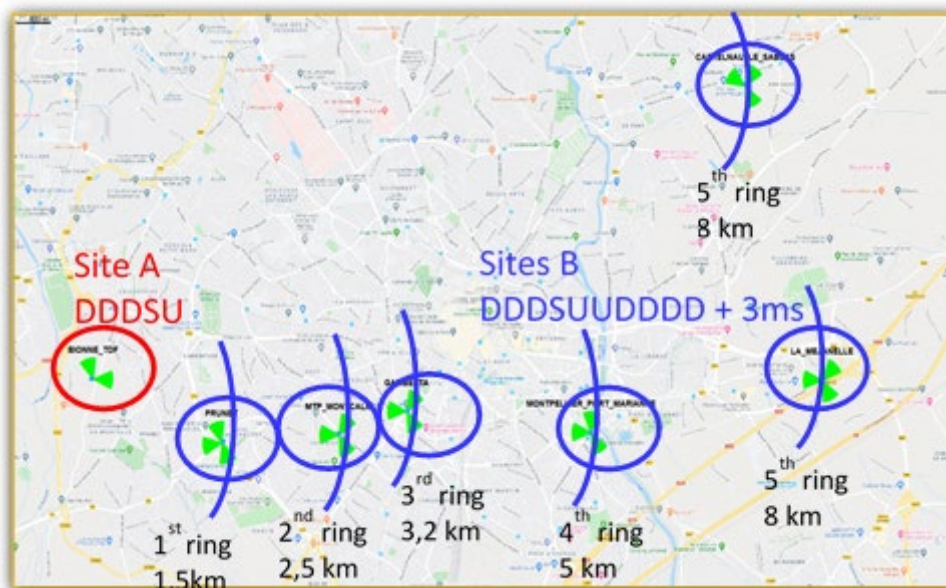

Figure 32: Field Test configuration

During the field test, both tests at static points (6 fixed points) and driving tests have been performed. Two test configurations:

- 1 Test_I: Co-channel with 80 MHz channel bandwidth, both Site A and Sites B are using the same channel with 80 MHz channel bandwidth;
- 2 Test_II: Adjacent channel with 40 MHz channel bandwidth, Site A and Sites B are using the adjacent channels with 40 MHz channel bandwidth without additional guard band.

Tests results are summarised in section A5.3.

A5.3 FIELD TEST RESULTS

A summary of the tests results is given in Figure 33. UL Noise Rise (NR), UL throughput loss, DL throughput loss and Latency degradation for each site at different separation distance are illustrated.

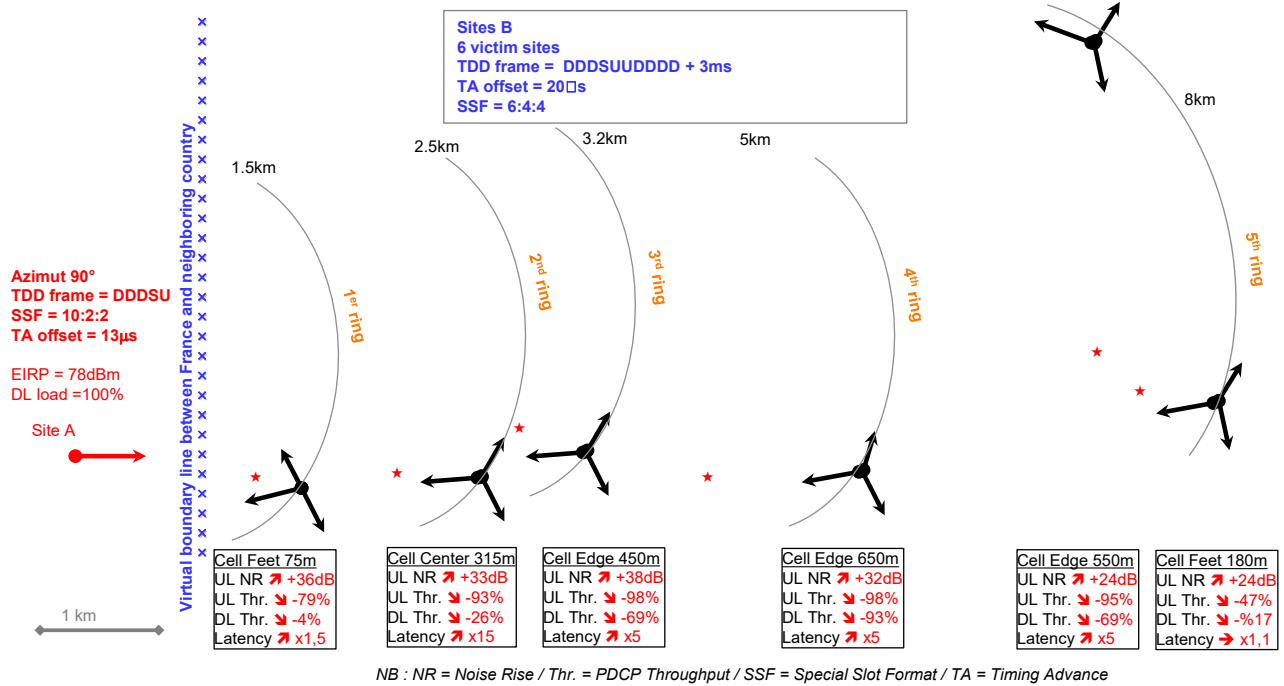

Figure 33: Test results summary

As illustrated in Figure 33, at a separation distance of 8 km between the Site A and 5th ring Site B, for UEs at cell edge, UL throughput loss is 95% and DL throughput loss is 69%, while for UEs at cell foot near BS, UL throughput loss is 47% and DL throughput loss is 17%.

Static points test results (RLC throughput) are summarised in Table 20. The static points test results show for both co-channel and adjacent channel cases, there are important UL throughput losses. Adjacent channel tests show much lower DL throughput because the channel bandwidth is divided by a factor of 2. These test results do not show any advantage of implementing the option of preferential frequency blocks.

These field test results are much worse than the simulated results presented in ANNEX 2. One explanation is that due to different frame structures the DL to UL timeslot collision can happen on the slot containing reference/control signals. In this case the impact is significant and it affects also the other slot. It demonstrates that when two different frame structures are used in neighbouring countries, an interference mitigation solution, e.g. Downlink Symbol Blanking is needed to mitigate the DL to UL timeslots collision, otherwise, a high UL and also DL throughput loss can occur.

Table 21: Static points test results (RLC throughput)

Test	1st ring Point to Site A: 1.5 km and at cell feet (75 m)	2nd ring Point to Site A: 2.5 km and at cell centre (315 m)	3rd ring Point to Site A: 3.2 km and at cell edge (450 m)	4th ring Point to Site A: 5 km and at cell edge (650 m)	5th ring Point to Site A: 8.2 km and at cell feet (180 m)	5th ring Point/Site A: 7.8 km and at cell edge (550 m)
I (Co-channel)	UL: 13 Mbps (68) Loss: 78%	UL: 1.7 Mbps (23) Loss: 93%	UL: 0,03 Mbps (4) Loss: 99%	UL: 0.04 Mbps (2,3) Loss: 98%	UL: 39 Mbps (74) Loss: 47%	no data recorded
	DL: 816 Mbps (851)	no data recorded	DL: 77 Mbps (245) Loss: 69%	DL: 10 Mbps (151) Loss: 93%	DL: 435 Mbps (527) Loss: 17%	DL: 55 Mbps (178) Loss: 69%
II (Adjacent Channel)	UL: 30 Mbps (34)	UL: 3 Mbps (11) Loss: 87%	UL: 0,2 Mbps (4) Loss: 94%	UL: 0.2 Mbps (1.1) Loss: 98%	UL: 39 Mbps (37)	UL: 0.9 Mbps (0.6)
	DL: 442 Mbps (425)	DL: 192 Mbps (206)	DL: 64 Mbps (120)	no data recorded	DL: 239 Mbps (265)	DL: 98 Mbps (89)

ANNEX 6: LIST OF REFERENCES

- [1] [ECC Recommendation \(15\)01](#): “Cross-border coordination for Mobile/Fixed Communications Networks (MFCN) in the frequency bands: 694-790 MHz, 1427-1518 MHz and 3400-3800 MHz”, approved February 2015 and latest amended 14 February 2020
- [2] [ECC Recommendation \(20\)03](#): “Frame structures to facilitate cross-border coordination of TDD MFCN in the frequency band 3400-3800 MHz”, approved 23 October 2020
- [3] [ECC Report 216](#): “Practical guidance for TDD networks synchronisation”, approved August 2014
- [4] [ECC Report 296](#): “National synchronisation regulatory framework options in 3400-3800 MHz: a toolbox for coexistence of MFCNs in synchronised, unsynchronised and semi-synchronised operation in 3400-3800 MHz”, approved March 2019
- [5] ERC Recommendation (01)01: “Cross-border coordination for mobile/fixed communications networks (MFCN) in the frequency bands: 1920-1980 MHz and 2110-2170 MHz”, approved 2001 and latest amended February 2016
- [6] [ECC Recommendation \(11\)05](#): “Cross-border Coordination for Mobile/Fixed Communications Networks (MFCN) in the frequency band 2500-2690 MHz”, amended February 2017
- [7] 3GPP TS 38.213 V16.6.0/ETSI TS 138.213: “NR; Physical layer procedures for control”
- [8] Recommendation ITU-R P.1546-6: “Method for point-to-area predictions for terrestrial services in the frequency range 30 MHz to 4 000 MHz”
- [9] 3GPP TS 38.101: “NR; User Equipment (UE) radio transmission and reception”;
- [10] Report ITU-R M.2292: “Characteristics of terrestrial IMT-Advanced systems for frequency sharing/interference analyses”
- [11] [ECC Report 309](#): “Analysis of the usage of aerial UE for communication in current MFCN harmonised bands”, approved July 2009
- [12] ECC Report 281: Analysis of the suitability of the regulatory technical conditions for 5G MFCN operation in the 3400-3800 MHz band”, approved July 2018
- [13] ECC Report 295: Guidance on Cross-border coordination between MFCN and Aeronautical Telemetry Systems in the 1429-1518 MHz band”, approved March 2019
- [14] 3GPP TS 38.104: “NR; Base Station (BS) radio transmission and reception”
- [15] Recommendation ITU-R M.2101: “Modelling and simulation of IMT networks and systems for use in sharing and compatibility studies”
- [16] Recommendation ITU-R F.1336: “Reference radiation patterns of omnidirectional, sectoral and other antennas for the fixed and mobile service for use in sharing studies in the frequency range from 400 MHz to about 70 GHz”