



Electronic Communications Committee (ECC)
within the European Conference of Postal and Telecommunications Administrations (CEPT)

**GUIDANCE MATERIAL FOR ASSESSING THE SPECTRUM REQUIREMENTS
OF THE FIXED SERVICE TO PROVIDE INFRASTRUCTURE
TO SUPPORT THE UMTS/IMT-2000 NETWORKS**

Sesimbra, October 2002

INDEX TABLE

1	INTRODUCTION.....	1
2	UMTS/IMT-2000 NETWORK.....	1
2.1	MARKET ASPECTS	1
2.1.1	<i>Capacity requirement forecast methodology.....</i>	<i>1</i>
2.1.2	<i>Market evolution</i>	<i>4</i>
2.2	UMTS/IMT-2000 NETWORK TOPOLOGY	4
2.2.1	<i>Radio Access Network.....</i>	<i>5</i>
2.2.1.1	Layer Structure within the Radio Access Network.....	5
2.2.1.2	Cell Implementation.....	6
2.2.2	<i>Transport Network</i>	<i>7</i>
2.2.2.1	Layer structures within UMTS/IMT2000 Networks	7
2.2.2.2	Node B Access below the Node A	9
2.2.2.3	Transport Network structures above Node A	12
2.2.2.4	The combined point-to-multipoint/point-to-point solutions for the mobile transport radio access network.....	13
2.3	TRANSPORT CAPACITIES AND MEDIA	16
3	FS APPLICATIONS WITHIN UMTS/IMT-2000 TRANSPORT NETWORKS.....	17
3.1	CHARACTERISTICS OF FIXED SERVICE BANDS.....	17
3.2	TECHNOLOGICAL REQUIREMENTS AND TRENDS FOR PP AND PMP SYSTEMS	21
3.2.1	<i>Maximising spectrum utilisation</i>	<i>21</i>
3.2.1.1	Benefits of using a combination of low and high modulation schemes in PP networks	21
3.2.1.2	PMP and PP spectrum efficiency comparison.....	21
3.2.2	<i>Traffic handling capability.....</i>	<i>22</i>
3.2.3	<i>Transport mechanism.....</i>	<i>22</i>
3.2.4	<i>Planning microwave transmission, availability and quality</i>	<i>22</i>
3.2.5	<i>Protection.....</i>	<i>22</i>
3.3	LINK DENSITY	23
3.4	COMPARISON OF THE TOPOLOGY AND THE BAND CHARACTERISTICS	23
3.4.1	<i>Comparison of the topology and band characteristics described in section 3.1</i>	<i>23</i>
3.4.2	<i>Other factors to be taken into account when considering bands for the UMTS/IMT-2000 infrastructure.....</i>	<i>24</i>
3.5	UPGRADE OF EXISTING 2G LINKS INTO 3G LINKS	26
3.5.1	<i>Evolution of 3G networks.....</i>	<i>26</i>
3.5.2	<i>Technology limitations</i>	<i>26</i>
3.5.3	<i>System Gain.....</i>	<i>27</i>
3.5.4	<i>Location Sharing.....</i>	<i>28</i>
3.6	INFRASTRUCTURE SHARING BETWEEN 3G OPERATORS	28
4	FREQUENCY ASSIGNMENT ASPECTS.....	29
4.1	CONVERSION OF 2G INFRASTRUCTURE ASSIGNMENTS INTO A COMBINED 2G/3G INFRASTRUCTURE NETWORK.....	29
4.1.1	<i>Possible changes in core network frequency requirements.....</i>	<i>30</i>
4.1.2	<i>Possible changes in access network frequency requirements</i>	<i>30</i>
4.2	BLOCK ASSIGNMENTS/INTER-OPERATOR PROTECTION MEASURES	30
4.2.1	<i>Advantages and disadvantages of block assignments</i>	<i>30</i>
4.2.2	<i>Inter operator protection measures in block assignment scenarios.....</i>	<i>31</i>
4.2.2.1	Example assignment scenario with guard band.....	31
4.2.2.2	Example assignment scenario without guard band.....	32
4.2.3	<i>Norwegian block assignment policy.....</i>	<i>33</i>
4.2.4	<i>Link by link assignment procedure in the UK</i>	<i>34</i>
4.2.5	<i>Conclusion.....</i>	<i>34</i>
5	CONCLUSIONS	34
	ANNEXES 1-5	

1 INTRODUCTION

Fixed service (FS) application will be necessary to support the operation of UMTS/IMT-2000 networks in the radio access network as well as in the transport network.

This Report gives an indication of possible structures of UMTS/IMT-2000 infrastructure networks including the market aspects of 3-G cellular systems, the radio access network, the transport network and provides a basis for the identification of radio spectrum requirements and suitable bands for this type of application. Regardless of the transmission network capacity, the final designation of frequency bands will depend on the local situation of the various countries (technical characteristics, existing deployment of the frequency bands, number of mobile (UMTS/IMT-2000) operators, etc.).

It should also be noted that within this report, the calculation of the possible capacity requirements of 3G networks does not take into account the relief in capacity within existing 2G networks in the context of 2G-3G migration.

A key element in this respect are the cellular structures, since the density of cells will determine the structures and capacities in the radio access network and as well as the transport network. It is obvious that in the transport network of UMTS/IMT-2000 infrastructure where no fibre optics are available, classical long haul bands below about 13 GHz might become essential. Other bands, such as 18 GHz and 23 GHz the HDFS bands (i.e. 32 GHz, 38 GHz and 52 GHz), especially for the UMTS-base station access will become vital.

2 UMTS/IMT-2000 Network

UMTS/IMT-2000 networks will offer mobile wideband multimedia services with high data rate up to 2 Mb/s offering a quality of service comparable to fixed networks. This requires huge transmission capacity especially in local areas of:

- high population;
- concentrated industrial activity; or
- campus settings.

The transport network of UMTS/IMT-2000 will consist of different transport layers to support the transmission interfaces.

The network structures of the UMTS/IMT-2000 Radio Access Network and the transport network will be determined by the capacity requirements of the UMTS/IMT-2000 market. In order to get a realistic picture of future network structures, the market forecast of UMTS/IMT-2000 is the key issue for identifying the framework in which 3rd generation mobile networks will be operated.

2.1 Market aspects

The basis for all considerations concerning network structures of future UMTS/IMT-2000 networks are the market expectations for mobile communication services within the framework of 10 years from now. The key issue in this respect is the forecast of the required communication capacity for up- and down-link operation of the mobile users within future UMTS/IMT-2000 networks.

Estimations of the market expectations for mobile communication services need to be based on a market forecast tool, being usable for many regions of the world with varying demographical and economical data. The basic principles of such market forecast calculations are provided by Rec. ITU-R M.1390, a methodology for the calculation of UMTS/IMT-2000 terrestrial spectrum requirements. However, spectrum requirement calculations are focused on the peak capacity requirements e. g. in densely populated regions or central business districts. In order to estimate full network structures, which are necessary to provide service to the customers, consideration of regions outside the hot spots of a network is necessary as well. Furthermore the impact of market shares has to be considered for the purpose of estimating the network structures of a certain provider.

2.1.1 Capacity requirement forecast methodology

UMTS/IMT-2000 will provide multimedia services and high speed data services, as well as speech and low speed data services currently delivered by 2nd generation Mobile Service systems. Therefore, calculations of the

capacity requirement have to be made by taking account of the future market for mobile networks, including those provided currently by 2nd generation systems.

The capacity requirement calculated for terrestrial UMTS/IMT2000 shall be based on several factors:

- Market forecast and penetration
- Potential user density
- Service and traffic characteristics
- Infrastructure and technical characteristics.

The UMTS/IMT-2000 comprises a wide area of applications. These may be classified into six main service classes as follows:

Speech symmetric (S) :	Simple one to one and one to many voice (teleconferencing) services Voicemail
Simple Messaging (SM): (asymmetric)	SMS (short message delivery) and paging Email delivery Broadcast and public information messaging Ordering/payment (for simple electronic commerce)
Switched Data (SD): (symmetric)	Low speed dial-up LAN access Internet/Intranet access Fax
Medium Multimedia (MMM): (asymmetric)	Asymmetric services which tend to be ‘bursty’ in nature, require moderate data rates, and are characterised by a typical file size of 0.5 Mbytes, with a tolerance to a range of delays. They are classed as packet switched services. Applications include: <ul style="list-style-type: none"> • LAN and Intranet/Internet access • Application sharing (collaborative working) • Interactive games • Lottery and betting services • Sophisticated broadcast and public information messaging • Simple online shopping and banking (electronic commerce) services
High Multimedia (HMM): (asymmetric)	Asymmetric services which also tend to be “bursty” in nature, require high bit rates. These are characterised by a typical file size of 10 Mbytes, with a tolerance to a range of delays. They are classed as packet switched services. Applications include: <ul style="list-style-type: none"> • Fast LAN and Intranet/Internet access • Video clips on demand • Audio clips on demand • Online shopping
High Interactive Multimedia (HIMM): (symmetric)	Symmetric services which require reasonably continuous and high-speed data rates with a minimum of delay. Applications include: <ul style="list-style-type: none"> • Video telephony and video conferencing • Collaborative working and telepresence

In order to get results which are in compliance with the requirements of different types of users of the available services, different geographical operating environments have to be considered in the forecast process e.g.:

- Central Business District (CBD)
- Urban pedestrian,
- Urban Vehicular
- Suburban and
- Rural.
-

The capacity requirement calculation shall take place independently for each case, with a final summation giving the total capacity requirement for the several environments.

The first stage in the calculation is to derive the total number of users per km² for each of the geographical service classes. This can be derived by multiplying the population density by the service penetration.

Each service in each environment generates:

- a particular call rate (calls/hour);
- a particular call duration (s) and
- a particular bit rate (Kb/s).

Further multiplication generates the bit requirement (kbit/hour/km²). The bit requirement must be increased to take account of a coding factor, overhead for signalling and packet retries and blocking for circuit switched services. This gives the figure for the Offered Bit Quantity (Mbit/hour/km²).

The methodology of the calculation of Offered Bit Quantity (OBQ), illustrated by Figure 1, shall be based on the population density in the region under consideration. This population density may be divided e. g. into three main environment classes:

- urban,
- suburban and
- rural.

The offered bit quantity (OBQ) can be obtained by applying equation (1)

$$OBQ = \text{busy hour call attempts} \times \text{penetration} \times (\text{pot. users}/\text{km}^2) \times \text{service bandwidth} \times \text{effective call duration} \quad (1)$$

The terrestrial capacity calculations of a European scenario, based on this methodology, is given as an example calculation in Annex 1.

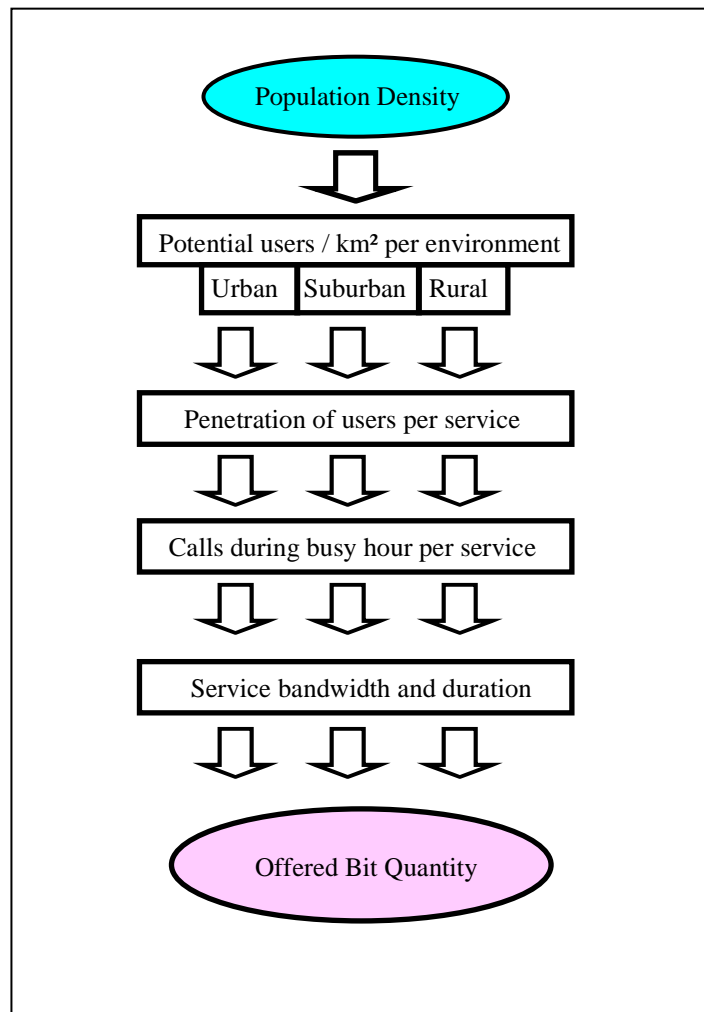

Figure 1: Calculation of the Offered Bit Quantity (OBQ)

2.1.2 *Market evolution*

With respect to requirements of the network operators in terms of:

- efficient planning
- fast network rollout
- cost effectiveness

the evolution of UMTS/IMT-2000 networks needs to be considered as well. Operators need the freedom to decide in which way the rollout of their network will evolve. On the other hand cost effectiveness requires a high grade of flexibility in the development of the backbone structures.

In order to reflect the evolution process of the cellular networks and the ongoing development in the access networks of UMTS/IMT-2000 networks, the evolving rollout process has to be considered as well:

- The initial network rollout, which will cover those regions, where sectorised cells in the mature deployment macro cell implementations are expected.
- Considering, that GSM networks will exist in parallel with UMTS/IMT-2000, and 3G will offer complementary services, as well as the fact that in some countries only two FDD channels are initially available for the network operators (additional frequencies are expected to be made available in future), the second step of network deployment will provide additional capacities especially in densely populated areas.
- The third step of the network deployment scenario is the mature cellular network on the basis of the expected market of mobile service (2G and 3G).

2.2 UMTS/IMT-2000 Network Topology

A general overview of the UMTS/IMT-2000 network topology is given in Figure 2. The Mobile Service Network in the scope of UMTS/IMT-2000 is the UMTS Terrestrial Radio Access Network (UTRAN), which represents the interconnection between the mobile user and the UMTS/IMT-2000 network. This mobile infrastructure needs to be supported by a Transport Network, which organises the transport of information between the mobile users concentrated at the Node Bs and the interconnection to the fixed network as well.

The interconnections between UTRAN and the transport network, as well as the interfaces within the transport network itself will define the requirements concerning capacities and media for interconnecting all levels of the network hierarchy.

In principle, the UMTS/IMT-2000 network hierarchy will consist of three different layers:

- Mobile Switching Centres in the UMTS/IMT-2000 network (MSC) organising the overall traffic flow as well as representing the interconnection to the fixed network;
- Radio Network Controller (RNC), the basic nodal within the network with switching functions for the subordinated base stations in the UMTS;
- Base stations in the UMTS/IMT-2000 (Node B).

Three main transmission interfaces (see Figure 2) has to be supported by the transport network:

- interface between Node B and RNC (Iub-interface);
- interface between RNCs (Iur-interface);

interface between RNC and MSC (Iu-interface).

Additional traffic concentration at certain points (Node A and TCP; traffic collection point), is possible by deployment of ATM-switches serving sub-networks especially in densely populated regions by combining a certain number of Base Stations. This further nodal concentration is part of the UTRA transport network. Detailed sub-network structure including Node A and TCP is explained in Section 2.2.2.

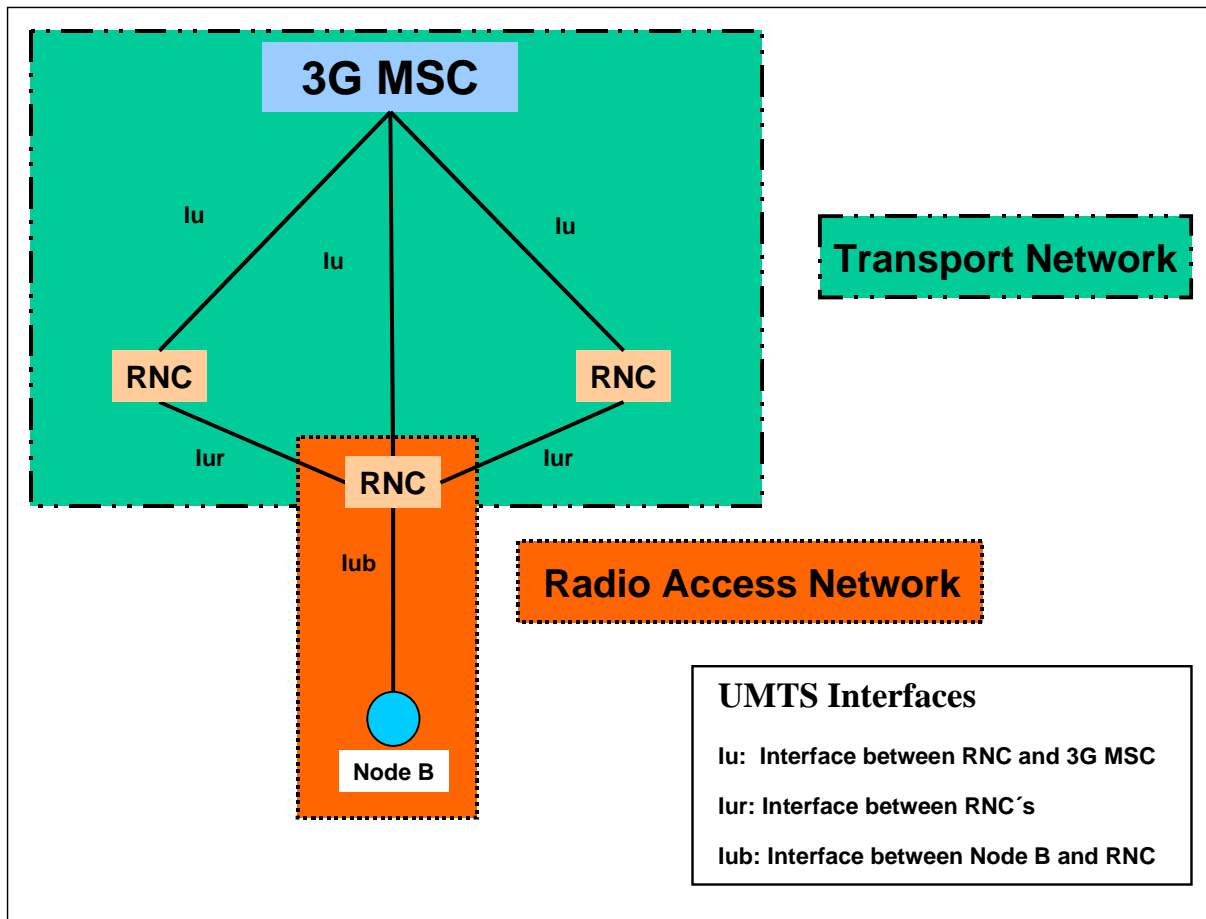

Figure 2: Topology of UMTS/IMT-2000 networks

The interfaces between the different layers within the UMTS/IMT-2000 network will define media and as well the amount of transport capacity, which are necessary for the operation of UMTS/IMT-2000 networks. On the other hand the evolution of UMTS/IMT-2000 network requires an extremely high grade of flexibility in the development process. Thus fixed wireless links will be the most efficient transport media. In the start phase most of the connections will be operated by fixed wireless links. With growing of a mature UMTS/IMT-2000 network especially high capacity connections will be substituted by fiber optics or other media.

2.2.1 Radio Access Network

The UMTS/IMT-2000 Radio Access Network (UTRAN) represents the mobile access to UMTS/IMT-2000 network. The communication within UTRAN will be organised in a hierarchical layer structure. Different cell sizes are necessary in order to accommodate the different communication requirements with respect to capacities and mobility aspects in different geographical areas.

2.2.1.1 Layer Structure within the Radio Access Network

The layer structure of UTRAN is given in Figure 3. An example of characteristics of the different layer implementations is given in Table 1.

Cell Implementation	rural	macro	micro	pico
Cell Radius	8 km	2 km	0.5 km	0.125 km
Application	high mobility	high mobility	low mobility/pedestrian	indoor/pedestrian

Table 1: Expected cell structure in the UMTS

Due to the large service area in combination with the limited offered capacity, rural cells are useful, especially if full terrestrial network coverage shall be achieved, even in regions with very low user density. Global coverage can be provided only by additional satellite applications.

According to the capacity requirements in different operational environments the cell structures of UTRAN will be organised in a hierarchical structure, where, especially in urban areas, several layers will be simultaneously operated in the same geographical region, having different cell implementations. The different cell implementations of UMTS/IMT-2000 networks will be operated on an economical basis only in areas where a demand for this service is expected (e.g. enough customers in the region concerned). Thus, the basis of any consideration of structures of the UTRAN need to be grounded on the realistic picture of the necessary cell implementations accommodating the capacity requirements in different operational environments.

The key element of UTRAN is the Radio Network Controller (RNC) which organises the mobile part of the UMTS/IMT-2000 network. The RNC controls the communication activities within the service area of several Base Stations of the UMTS/IMT-2000 network (Node B). These Node B may be organised in sub-networks, especially in urban areas where high capacity demand is expected. Such sub-network may be controlled by an ATM-switch (including soft hand-over procedures), which will be the nodal of the sub-network.

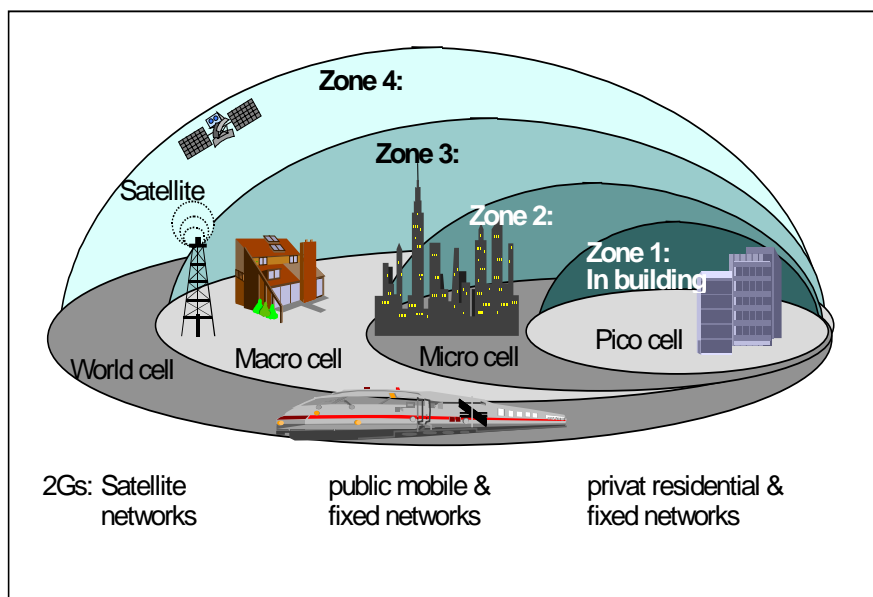

Figure 3: Structure of UMTS/IMT-2000 Radio Access Network

2.2.1.2 Cell Implementation

In order to achieve a full coverage network of UMTS/IMT-2000 in a region under consideration, hexagon cells are the most suitable approach for the modelling of such networks. In the case of high capacity requirements in its cell area, hexagon cells may be sectored according to the simplified method given in Figure 4.

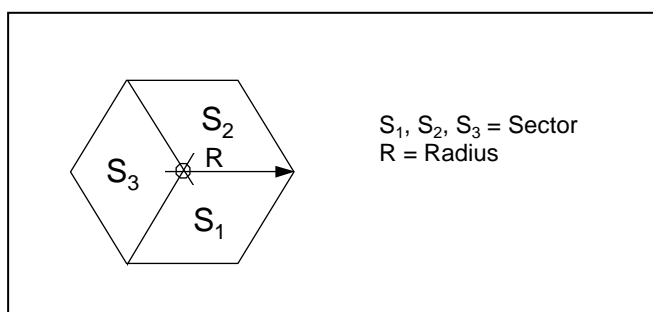

Figure 4: Model for sectored cells

The different expected densities of potential users/km² in the several operational environments leads to different cell types which are necessary to accommodate these requirements. Table 2 gives an overview of the dominating cell structures for the different operational environments.

Operational environments	Cell Type			
	Rural	Macro	Micro	Pico
CBD/Urban (in building)			•	•
Urban pedestrian		•	•	
Urban vehicular		•	•	
Suburban (in building or on street)		•		
Rural in- & out-door	•	•		
Remote	•			

Table 2: Cell implementations for different operational Environments

Due to requirements for macro, micro and pico-cells for serving densely populated / urban regions, in such geographical areas more than one cell implementation will be operated in parallel. Soft hand-over within the layers has to be taken into consideration. On the other hand no user will occupy more than one operational environment at the same time (hard hand-over). In order to identify the cell structures and densities in all regions under consideration, the characteristics of the cell implementations have to be considered; including assumptions concerning technical characteristics like expected capacities and antenna siting conditions.

2.2.2 Transport Network

2.2.2.1 Layer structures within UMTS/IMT2000 Networks

The characteristics of UMTS/IMT-2000 cell implementations will lead to high densities of cells especially in densely populated regions. Thus, the structure of the Radio Access Network has to be focussed on the conditions in those hot spots of UMTS/IMT-2000 networks. The interconnection between the cell implementations, the Radio-Network-Controller (RNC) and the core network need to be designed in the most effective way. The use of short haul microwave radio has evolved from “scattered” cable replacements to forming complete microwave based transmission networks. The requirements on the products have moved from optimization on terminal or hop level to network level. Figure 5 gives a general overview of the expected structures in urban areas of a UMTS/IMT-2000 network.

In the implementation of large networks, chaining many packet transmission equipment, the aggregate transmission delay need to be considered to keep it within allowed limits.

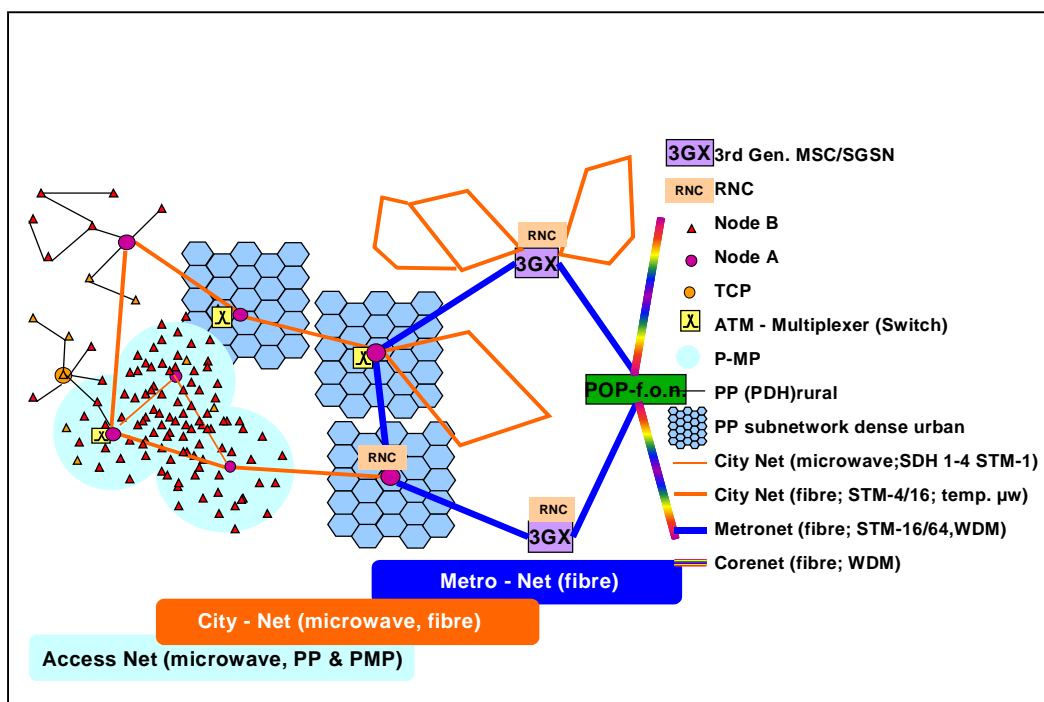

Figure 5: General Overview of a UMTS/IMT-2000 Transport-Network

The network architecture is also described in Figure 6. The network layers defined are Node B, Node A and TCP. Any microwave network can be implemented as a combination of those network layers.

To support scalability and flexibility TCP and Node A are specified to aggregate medium and large traffic capacity. Both point-to-point and point-to-multipoint as well as both E1 and ATM aggregating sites could be supported.

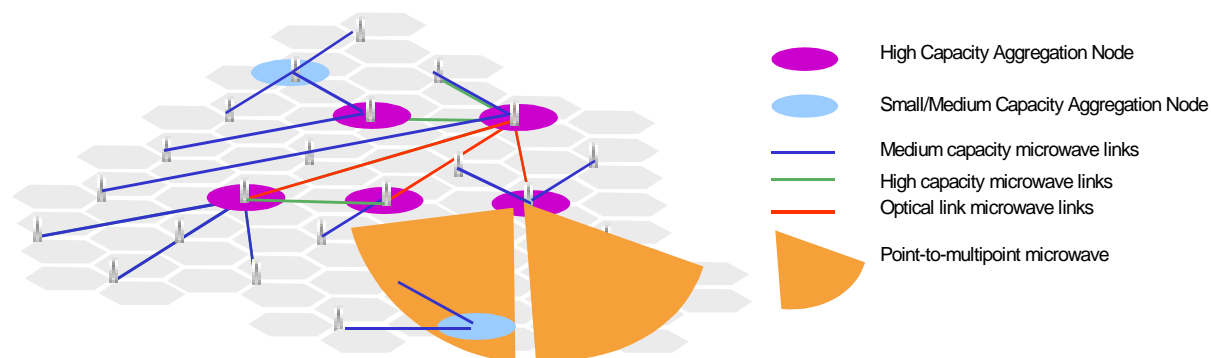

Figure 6: Network Architecture

2.2.2.1.1 Definition of Network Nodes

The following network layers for a microwave network can be identified:

2.2.2.1.1.1 Node B (End Node)

The Node B is the smallest network layer. By definition a Node B is supposed to be the End Node. Capacity is in most cases ranging from 2x2 up to 8 Mb/s. Normally no redundancy is required in those sites and therefore the normal microwave configuration is 1+0. Both point-to-point and point-to-multipoint Node Bs are foreseen. The Node B should be flexible in order to support traffic interfaces ranging from multiple E1's, E2, E3, STM-1 as well as Ethernet-interfaces. In a point-to-multipoint system the Node B preferably provides an ATM interface for WCDMA backhaul to take better advantages of the shared air interface.

2.2.2.1.1.2 TCP (Low/Medium Capacity Aggregation Node)

The Low/Medium Capacity Aggregation Node (TCP) is an optional network layer that can be hierarchically located between the Node B and the RNC or between the Node B and Node A (described in the next section), which could support traffic up to $n \times 34$ Mb/s ($n = 1, 2$ or even 3) from and to the RNC or Node A.

The solution to the TCP is to design nodes that can aggregate all the traffic from the Node B links into another microwave link to the RNC or Node A.

Both protected and non-protected configurations of the TCP could be supported. The solutions also support local drop and insert of traffic.

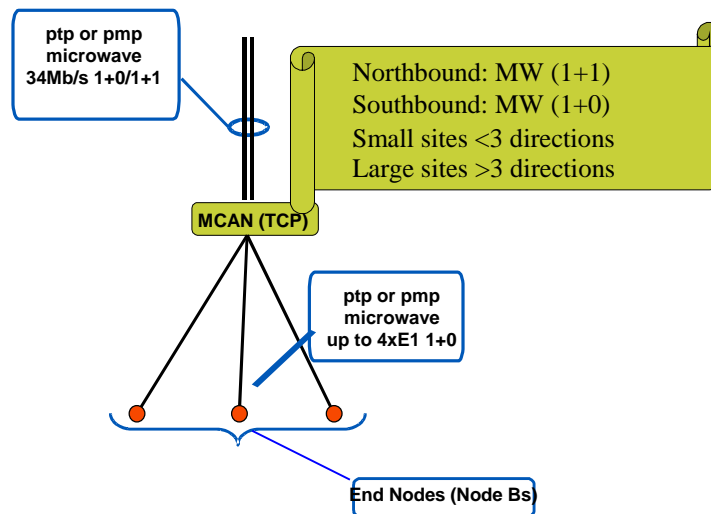

Figure 7: Network Architecture Node B and TCP

2.2.2.1.1.3 Node A (High Capacity Aggregation Node)

The High Capacity Aggregation Node (Node A) is an optional network layer that can be hierarchically located between the TCP and the RNC. The Node A will typically support a backhaul capacity of 155Mb/s from and to the RNC over either optical or microwave media in a ring or point-to-point topology. Parts of the Node Bs will be directly connected to the Node A and parts will be connected through the TCP.

Both point-to-point and point-to-multipoint as well as both E1 and ATM aggregating sites could be supported.

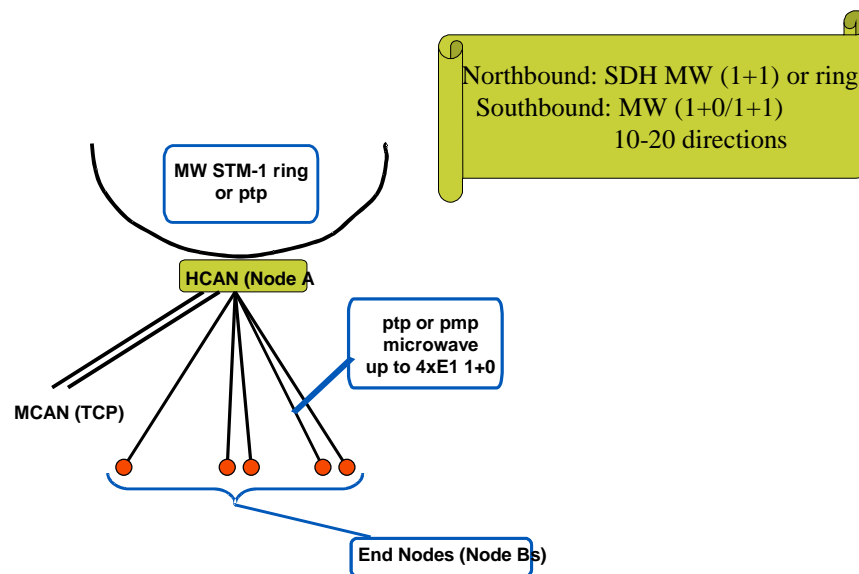

Figure 8: Network Architecture Node B and Node A

2.2.2.2 Node B Access below the Node A

Especially if large numbers of Node Bs need to be served by the RNC, sub-networks should be build in order to have additional nodal in network including ATM - switching functions. The Access can be achieved by point-to-point or point-to-multipoint structures.

2.2.2.2.1 Point-to-Point Applications

Fixed Service Point-to-Point (PP FS) wireless links will become a very important medium in the architecture of the Radio-Access –Network within UMTS/IMT-2000. The interconnection between Node Bs and the switching centres (TCPs and Node As) within the network is one of the main fields for these applications. Due to its high

flexibility, PP FS will dominate the access from the cell implementations to the network. Depending on the requirements concerning:

- hop length,
- required capacity,
- availability target,

suitable frequency bands for wireless link operation may be found. However, direct access to the Node B of a certain cell may lead to a hop length that would require link installations with big antennas. This may cause severe installation problems, especially at the Node As within the network. Thus, chains of PP FS links, instead of direct interconnection, need to be considered, including aggregation of capacities along the chain of links between cell Node B and switching centre especially in suburban and rural environment. In urban and dense urban environment Node B density will allow the effective use of star and sub star networks with pre-concentration functionality, introducing a concentration point (TCP). Figure 9 illustrates a possible sub-star network structure. Nevertheless conventional tree structures may still be a possible solution, since the driving force in mobile networks will always be the mobile coverage and not optimal transport network conditions. This fact will always require a certain flexibility by the transport network, resulting sometimes in higher spectrum demands.

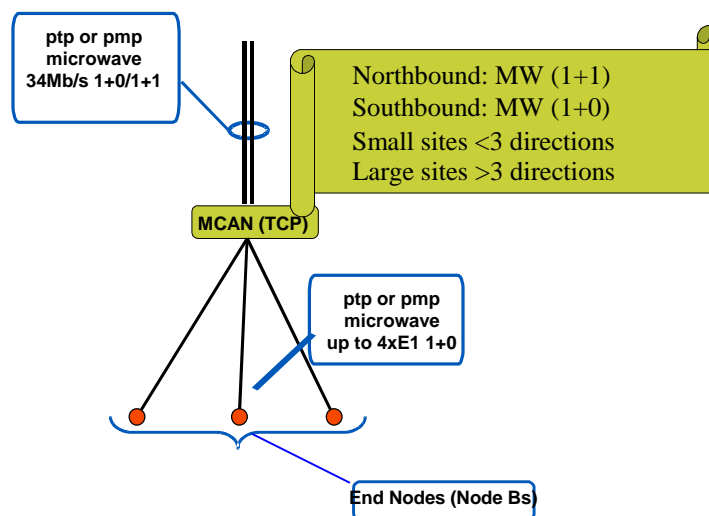

Figure 9: An Example of a sub-network structure for Node B access using sub star and chains of FS links

The use of PP applications has the advantages of:

- limited number of link installation for a certain location,
- variable hop length (according to network requirements),
- small antennas due to high frequencies to be used,
- reducing an extreme aggregation of capacities along chains
- flexibility in respect to changes/increase of required transport capacities and number of Node Bs.

Additionally, where the situation allows, a direct access method to construct links from the Node-A to surrounding Node-Bs has following advantages:

- all the base stations (Node-Bs) need to have only one antenna for the access network connection,
- payload division or interconnection to another radio access system at the base station is not necessary,
- line-of-sight condition to many base stations may be easily obtained if the Node-A has a high tower.

In particular the last item will be quite important since it is often difficult to obtain line-of-sight condition between Node Bs in actual cases. In this method the number of required RF channels may be increased on account of narrow branching angles between many converged access links. Figure 10 illustrates an example of access link deployment to the Node-Bs from the Node-A station.

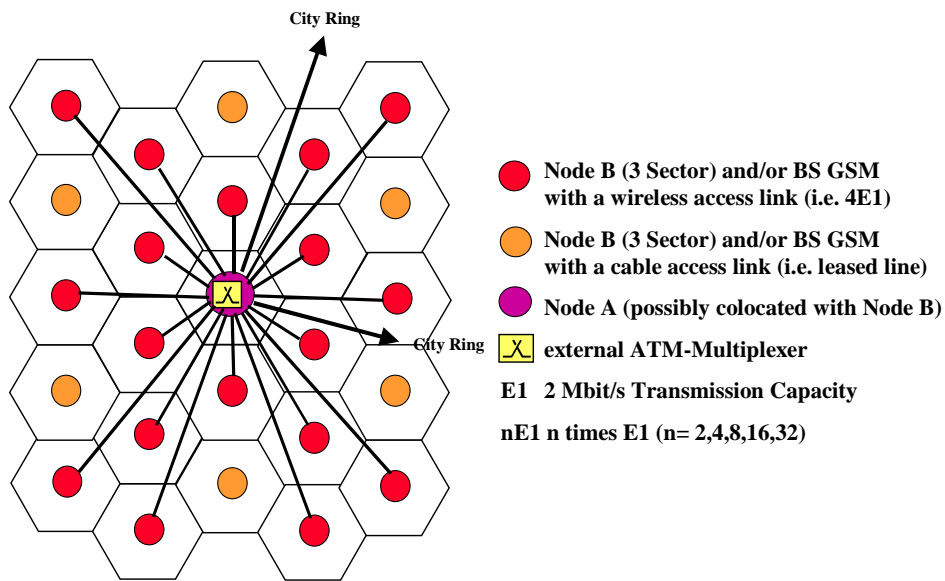

Figure 10: Example of using direct access link deployment to UMTS/IMT-2000 Node Bs

2.2.2.2.2 Point-to-Multipoint Applications

In areas of high density of UMTS/IMT-2000 cells, Point-to-Multipoint Fixed Service (PMP FS) applications might be a solution for accommodating the capacity requirements of interconnecting the cell Node Bs with the switching centres (TCP or Node A). PMP FS applications could have the ability to serve large numbers of cells, especially if sectored PMP FS systems are operated. This ability might be used within the UMTS/IMT-2000 networks in areas of high density of cells. The structures of such a PMP FS network are given in Figure 11. According to the individual requirements different transport capacities can be provided to the served Node Bs.

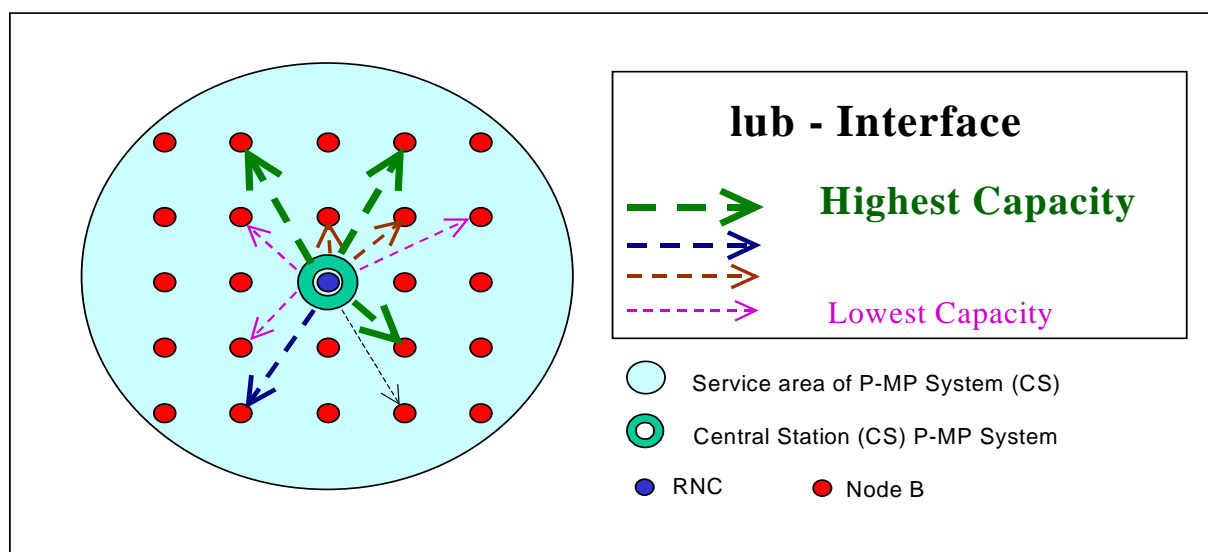

Figure 11: An Example of a PMP FS network structure

Furthermore, dynamic capacity allocation within the PMP FS system is possible and will increase the efficiency of these systems. The dynamic behaviour of the PMP Systems should adapt to the current traffic demands of the

served Node B within a sector. The reaction time should be typically below 1 second. The principles of the dynamic capacity allocation are shown in Figure 12.

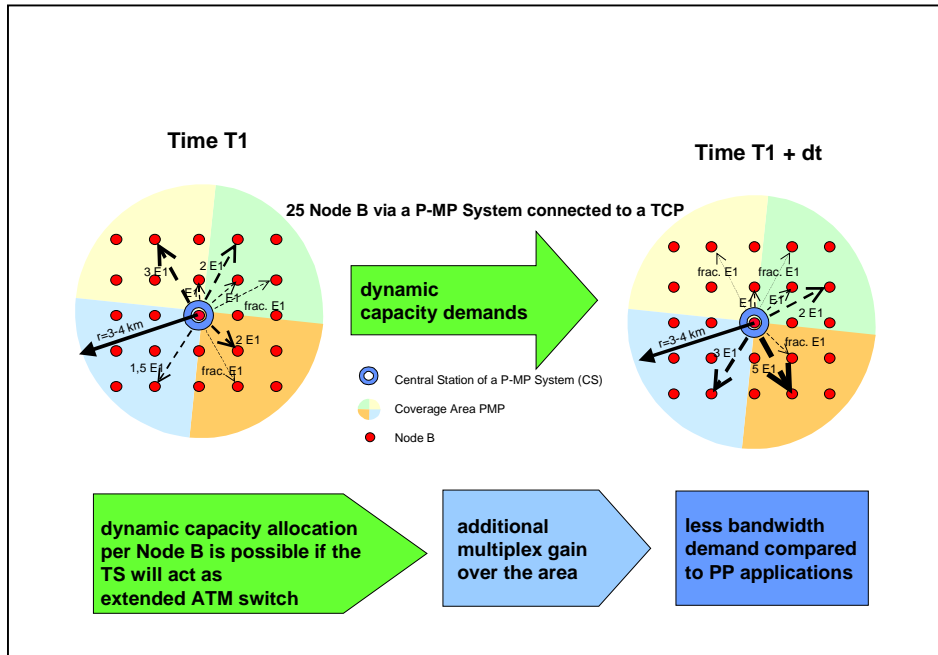

Figure 12: Dynamic capacity allocation in PMP FS systems

Point-to-multipoint systems use the spectrum in an efficient way by making use of some features such as:

- ATM Granularity Gain
- F-DCA (Fast dynamic capacity allocation) and ATM multiplexing.

In addition Point-to-Multipoint systems provide an environmental advantage by minimising the visual impact of many individual link antennas (as in case of PP links) mounted at a hub.

Details of these characteristics and their advantages are given in **Annex 3**.

2.2.2.3 Transport Network structures above Node A

The transport network above the Node A and the RNC within the UMTS/IMT-2000 will have the task to organise and operate the concentrated information in the direction of the RNC and further to the core network. A possible structure of this part of the network within UMTS/IMT-2000 infrastructure is given in Figure 13.

A certain number of Node As could be connected via a ring structure towards the next RNC location. Within the city ring structures, at least in the initial phases of network roll-out, a reasonable number of PP SDH links can be expected, furthermore only a few RNC locations may be required, since traffic concentration has already been applied at the concentration points (TCPs and Node As) by their ATM-multiplexing/switching functionality.

Above the RNC PP SDH links could be applied as well, but fibre optical connections may be preferred from the beginning.

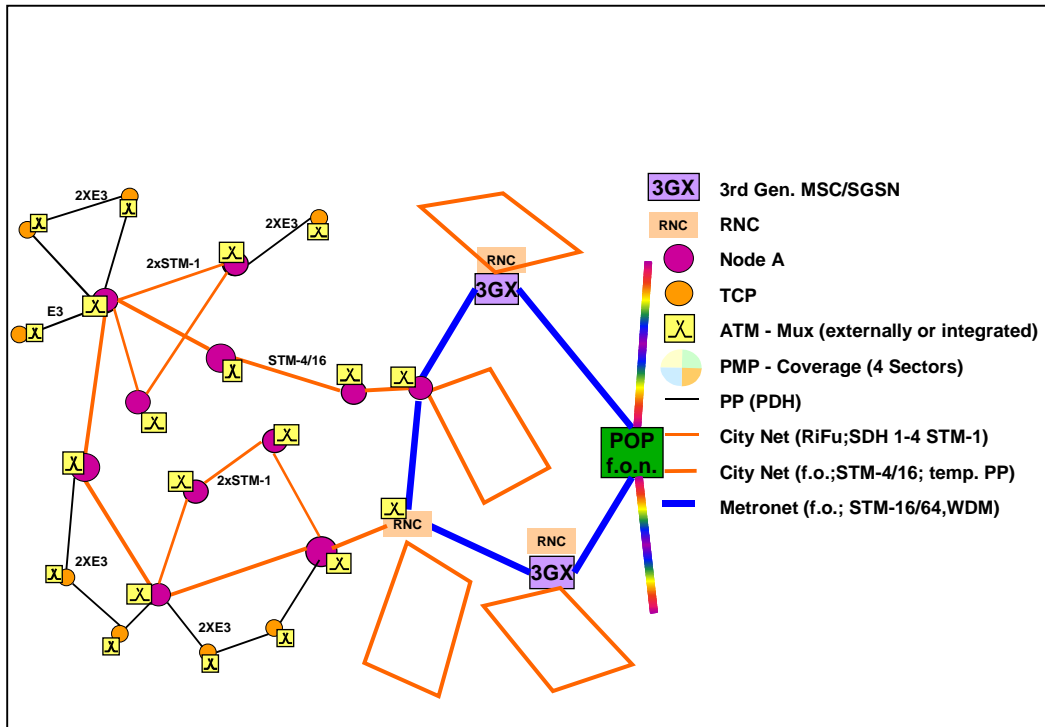

Figure 13: Possible Structure of the higher order Transport Network for UMTS/IMT-2000

2.2.2.4 *The combined point-to-multipoint/point-to-point solutions for the mobile transport radio access network*

The combination of the point-to-point and point to multipoint microwave product would potentially result in a spectrum efficient solution for the network.

- E1 aggregation via point-to-point links is typically suitable in hubs where the number of directions (or connected Node Bs) is limited and spectrum congestion is not an issue (the required bandwidth is likely to be a portion of that required for large hub deployment)
- ATM aggregation via point-to-multipoint is typically suitable in the hubs where the number of directions (or connected Node Bs) is high and spectrum efficiency is a of prime interest (as it determines the frequency block size requirement)
- The hubs are to be connected to each other and/or to the switch site via point-to-point systems in accordance with the required range, capacity and the available spectrum

In the following sub-sections some site solutions are introduced based on the combination of both point-to-point and point-to-multipoint equipment and applicable to the different operators' strategies are introduced.

2.2.2.4.1 E1 multiplexing node examples

A network based on E1 multiplexing nodes is most efficient in the case where the 2G traffic is predominant. It is also typical for operators wishing to reuse the existing network as much as possible (by exploiting the spare capacity on the microwave links or on STM-1 rings) Benefits include secure upgrade with minimum disturbance on existing traffic.

Figure 14 exemplifies how a combination of point-to-multipoint and point-to-point links can efficiently serve the TCP Node As. The following aspects can be outlined:

- Typically the TCPs handle from 2 to 4 Node Bs, i.e.: from 2 to 4 directions. These kind of nodes are typically deployed where the Node B density is small, the Node B-to-Node B distance is high and therefore the TCPs are required to provide a wide coverage range.
 - The TCPs interconnects the end Node Bs through point-to-point links.
 - The connection between TCPs and Node A can be via point-to-multipoint or point-to-point, depending on capacity, protection and range requirements.
- The Node As are typically located in sub-urban or urban areas where the Node B density is high, i.e. from 5 to 20 directions. Where possible, point-to-multipoint systems are likely to connect the Node Bs. Node Bs, which are out of the point-to-multipoint coverage range, are connected through point-to-point links.

In case of E1 aggregation the point-to-multipoint system circuit emulates the GSM traffic and connects to the point-to-point node through nxE1 which provides a single STM-1 VC12 interface towards the switch site.

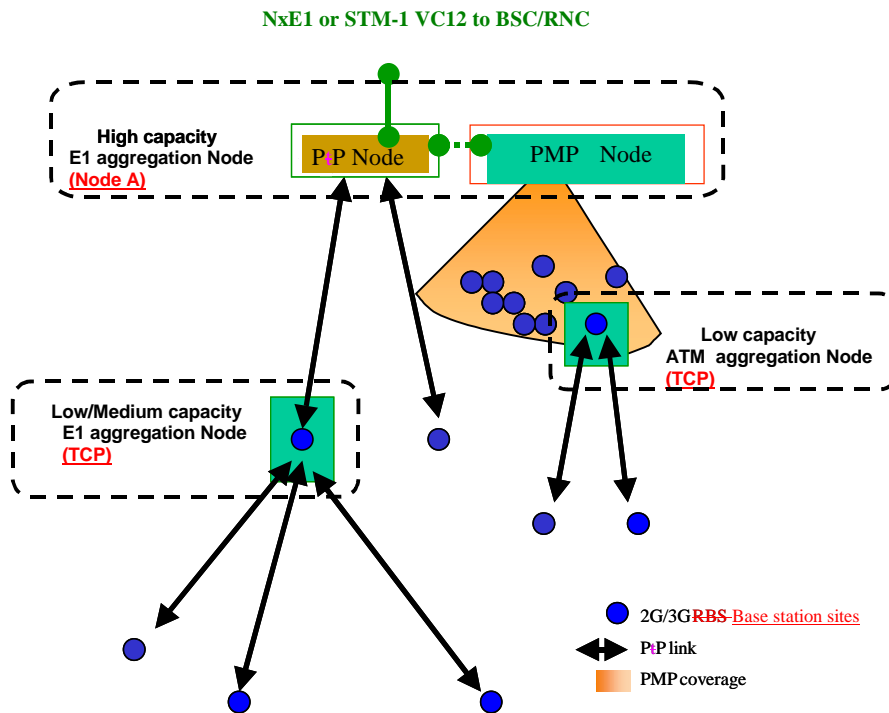

Figure 14: Example of site solutions based on E1 Multiplexing combining point-to-multipoint and point-to-point

The disadvantages of the E1 multiplexing solution include low expansion capability and a higher network cost in the medium/long term, which could suggest the ATM aggregation strategy as below described.

2.2.2.4.2 ATM aggregating Nodes examples

When 3G traffic becomes predominant over the 2G traffic, ATM aggregating nodes could provide a cost effective network solution. Networks based on ATM aggregating nodes are likely to be typical for green-field operators and for incumbent operators wishing to overlay the existing network or to replace the existing leased line connections.

The point-to-multipoint hub provides port aggregation, aggregating both the traffic from point-to-multipoint and point-to-point terminals and providing an efficient and cost effective solution for cellular backhaul applications. Also the traffic from leased lines and xDSL lines can be aggregated at the central station. For the connection to the RNC, a single ATM over STM-1 VC4 interface (Figure 15) could provide an efficient solution, which optimises backbone capacity and the Switch site complexity and cost.

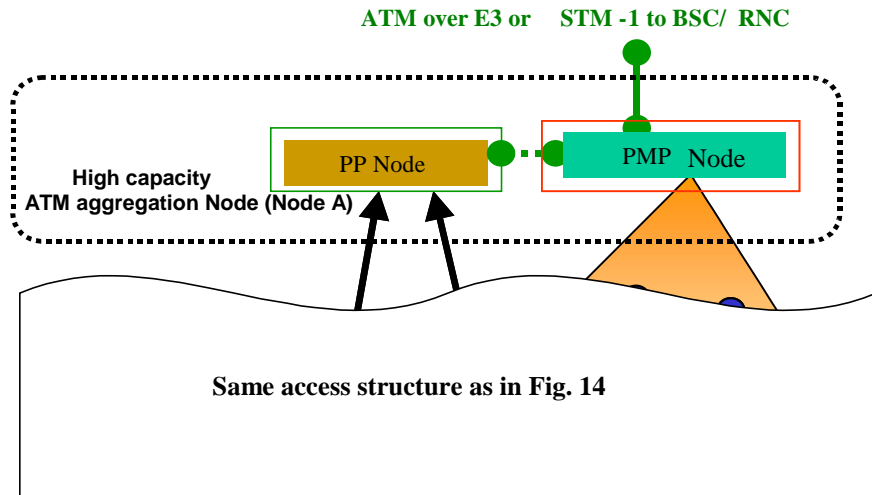

Figure 15: Example of High Capacity Aggregation Node handling ATM

2.2.2.4.3 Improved spectrum efficiency through a combination of point-to-multipoint/point-to-point systems

One fundamental issue in microwave network planning is the efficient use of the spectrum. National authorities and international committees regulate the spectrum availability. Point-to-point links typically require a license per link, while point-to-multipoint systems licences are issued as regional or national block allocations.

In addition it is worth noting that when PP and PMP systems can equally be used in the same frequency block then the spectrum efficiency could be optimised as described in the Figure 16 below.

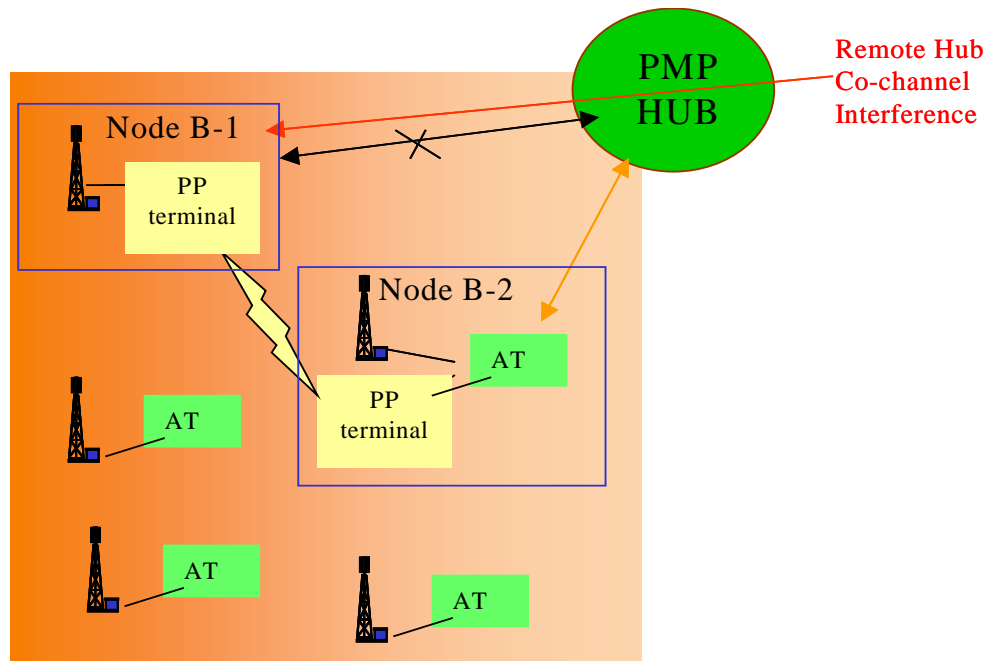

Figure 16: Combining point-to-multipoint and point-to-point allows a better frequency re-use development

The point-to-multipoint cellular deployment is such that a few locations inside the multipoint sector can experience excessive interference from neighbouring central stations. This effect could be minimised by avoiding the reuse of the frequency in neighbouring sectors or by combining the point-to-multipoint and point-to-point technologies. In figure 16 the Node B-1 location, if connected to the local hub through a point-to-multipoint terminal, would be affected by the co-channel interference from a remote point-to-multipoint central

station. When Node B-1 is instead connected to Node B-2 by means of a point-to-point link, the antenna angular discrimination improves the carrier to interference ratio and guarantee error free operation. It is worth noting that the point-to-point link can reuse part of the same point-to-multipoint spectrum, allowing for a spectrum efficient solution.

2.2.2.4.4 PP FS links in the PMP FS scenario

In some cases due to building obstruction along the propagation path or to meet high capacity requirement additional PP FS links may be necessary in the deployment area of PMP FS systems, see Figure 17.

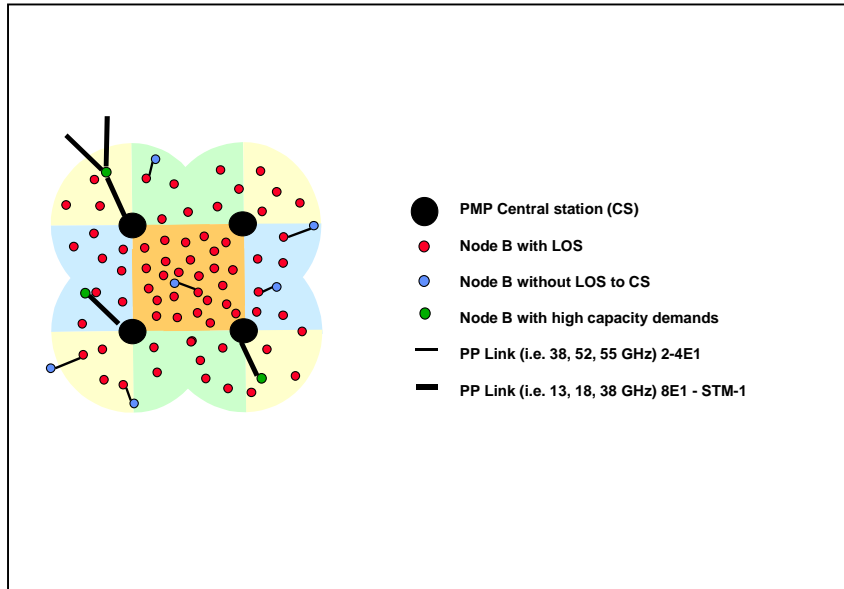

Figure 17: PP FS links in the PMP FS scenario

2.3 Transport Capacities and Media

A large variety of interconnections in terms of hop length and transport capacity are necessary to operate the UMTS/IMT-2000 networks. Not all of these connections within the UMTS/IMT-2000 network will necessarily be operated by radio equipment. Depending on:

- the network layer under consideration,
- technical facilities of a certain network operator,
- economical framework

a certain percentage of the interconnections within the UMTS/IMT-2000 networks will be operated on cables (e. g. DSL-Systems) or fibre optics.

In Table 3 the expected transport capacities are given for the interconnections between the different network layers. The evolution of the networks has been considered in that respect.

Layer	Short term	Long term
single Node B	2 E1 – 4 E1	2 E1 – E3
Node B --> TCP	4 E1 – E3	4 E1 – STM-1
TCP --> Node A	E3 – STM-1	n E3 – n STM-1
Node A --> RNC	E3 – 2 STM-1	n STM-1 – n STM 16
RNC --> MSC/SGSN	n STM-1	n STM1- n STM-16

Table 3: Expected link capacities for interconnecting the different layers of UMTS/IMT-2000 networks

Table 4 illustrates a variety of hop lengths in different operational environments (rural and urban) of the cellular network. Combining both information, capacity and hop length leads to a selection of media which would serve best these requirements in the different layers of the UMTS/IMT-2000 network.

Network Layer	Urban	Rural
single Node B	0.5 – 1.4 km	5 – 16 km
NodeB --> TCP	0.5 – 2.5 km	5 – 20 km
TCP --> Node A	2.0 – 5.0 km	5.0 – 20 km
Node A --> RNC	5 – 10 km	5.0 – 50 km
RNC --> MSC/SGSN	0 – 20 km	0 – 20 km

Table 4: Possible hop length ranges for interconnecting the different layers of UMTS/IMT-2000 networks

Table 5 gives the overview of the expected media as well as an indication of percentage of application within the different layers of the network. The indication of the importance of the media is described as low (< 10%), medium (10-30%) or high (> 30%). The evolution of the networks and corresponding changes of the requirements have been considered in that respect, expectations are given for the short term and the long term deployment.

Network Layer	Deployment phase					
	Short term			Long term		
	MW		FO	MW		FO
NodeB --> TCP	high		low	high		medium
TCP --> Node A	high		low	high		medium
Node A--> RNC	high	-	medium	medium	-	high
RNC --> MSC/SGSN	high	-	medium	low	-	high

Table 5: Expected media for interconnecting the different layers of UMTS/IMT-2000 networks

Below the TCP level fixed service applications will dominate. From the TCPs up to the Node As microwave applications might dominate in many networks for the next several years. ATM switching, ring structures and multiple routing techniques will become more and more essential. In the Transport network above the Node As, fibre optical applications are expected to dominate from the beginning or at least could become essential after several years.

The different network layers will have different requirements concerning communication capacity and availability targets due to its function within the UMTS/IMT-2000 network. These levels will build a four-layer transport network, which may be accommodated by different transport media:

- access net (Access from Node B to TCP and/or Node A) operated mainly by Point-to-Point (PP) and Point-to-Multipoint (PMP) microwave links or cable;
- City – Ring structures (Interconnection of Node A and the RNC) operated by Point-to-Point (PP) microwave links and fibre optics;
- metro net (Interconnection between RNC's, MSC's and possibly POP to fibre optics networks) operated mainly by fibre optics.
- core net (Interconnection between MSC) operated mainly by fibre optics.
- Scenarios where an interconnection of a certain layer within the transport network will carry traffic of lower transport network layers are possible as well.

3 FS APPLICATIONS WITHIN UMTS/IMT-2000 TRANSPORT NETWORKS

In this section the fixed service frequency bands and their appropriateness/usability for use in the UMTS/IMT-2000 is reviewed. A comparison of the topology and band specifics is provided taking into account the more technically and physically related band characteristics, possible link densities, requirements on systems today and in future, and other factors, which influence the appropriateness/usability of certain bands.

3.1 Characteristics of fixed service bands

Basically all frequency bands available for the Fixed Service could be used in the UMTS/IMT-2000 transport networks. In the following tables technical band characteristics such as appropriate transmission capacities, channel spacings, modulation levels, the available number channels and the typical link length are brought in relation.

It should be noted that in some cases national usage can vary from the more general characteristics described below. It further has to be noted that apart from these more technically and physically related characteristics as described in Tables 6 – 8 a number of other factors have to be taken into account which could have a significant impact on the usability of a number of bands. These factors are described in section 3.4 where the requirements for wireless links resulting from the UMTS/IMT-2000 network topology is compared with the band specifics.

Since the structure and the density of the UMTS/IMT-2000 transport network requires a high amount of frequencies (especially for short hops in the range of a few kilometres up to some tens of kilometres) most of the frequency bands of interest, especially for densely populated areas, shown in Table 6 and 7 below are located in the frequency range above 4 GHz and 11 GHz respectively. Although bands below 11 GHz may also be required for certain links in more scarcely populated areas within the UMTS/IMT-2000 infrastructure network. However, it should be recognised that fixed service bands below 3.6 GHz up to 11 GHz may also be required for certain links in more scarcely populated areas, where it is necessary to have long-hop lengths in order to minimise the number of sites. This is an important aspect in providing economical network access in remote areas.

Frequency Bands	Appropriate Transmission Capacity	Channel Spacings	No. of channels in the channel plan	Typical Link Length
4 GHz (3600 – 4200) CEPT/ERC/REC. 12-08 E	STM-1, nxSTM-1	40 MHz 29/30 MHz	7 6/9	20 – 80 km
	STM-0	20 MHz	14	
	34 Mb/s , 2x34 Mb/s , STM-0	15 MHz	18	
Lower 6 GHz (5925-6425) CEPT/ERC/REC. 14-01 E	STM-1, nxSTM-1	29.65 MHz	8	20 – 80 km
Upper 6 GHz (6425 - 7125) CEPT/ERC/REC. 14-02 E	STM-1, nxSTM-1	40 MHz	8	20 – 80 km
	STM-0	20 MHz	16	
7/8 GHz (7125 – 8400) ERC Rec. not available	STM-1, nxSTM-1, 100Mb/s , 2x34 Mb/s	28 MHz	5/8	20 – 80 km
	34 Mb/s , 2x34 Mb/s , STM-0	14 MHz	10/16	
	8x2 Mb/s , 4x2 Mb/s	7 MHz	20/32	
11 GHz (10.7-11.7) CEPT/ERC/REC. 12-06 E	STM-1, nxSTM-1	40 MHz	12	10 – 50 km
13 GHz (12.75-13.25) CEPT/ERC/REC. 12-02 E	STM-1, nxSTM-1, 100Mb/s , 2x34 Mb/s 34 Mb/s	28 MHz	8	5 – 35 km
	8x2 Mb/s , 34 Mb/s , STM-0	14 MHz	16	
	8x2 Mb/s , 4x2 Mb/s	7 MHz	32	
	4x2 Mb/s , 2x2 Mb/s	3.5 MHz	64	

Table 6 (continued): Characteristics of frequency bands for point-to-point fixed links

Frequency Bands	Appropriate Transmission Capacity	Channel Spacings	No. of channels in the channel plan	Typical Link Length
15 GHz (14.5-14.62/15.23-15.35) CEPT/ERC/REC. 12-07 E	2xSTM-1	56 MHz	2	5 – 30 km
	STM-1, nxSTM-1, 100Mb/s , 2x34 Mb/s	28 MHz	4	
	8x2 Mb/s , 34 Mb/s , STM-0	14 MHz	8	
	8x2 Mb/s , 4x2 Mb/s	7 MHz	16	
	4x2 Mb/s , 2x2 Mb/s	3.5 MHz	32	
18 GHz (17.7-19.7) CEPT/ERC/REC. 12-03 E	STM-1, nxSTM-1	55 MHz	17	4 – 25 km
	STM-1, 100 Mb/s , 2x34 Mb/s , 34 Mb/s	27.5 MHz	35	
	8x2 Mb/s , 34 Mb/s , STM-0	13.75 MHz	70	
	8x2 Mb/s , 4x2 Mb/s	7 MHz	136	
	4x2 Mb/s , 2x2 Mb/s	3.5 MHz	272	
23 GHz (22.0 – 23.6) Rec. T/R 13-02 E Annex A	2xSTM-1, STM-1	56 MHz	10	3 – 20 km
	STM-1, 100Mb/s , 2x34 Mb/s , STM-0, 34 Mb/s	28 MHz	20	
	8x2 Mb/s , 34 Mb/s , STM-0	14 MHz	41	
	8x2 Mb/s , 4x2 Mb/s	7 MHz	83	
	4x2 Mb/s , 2x2 Mb/s	3.5 MHz	168	
26 GHz (24.5 – 26.5) Rec. T/R 13-02 E Annex B	2xSTM-1, STM-1	56 MHz	16	2 – 15 km
	STM-1, 100Mb/s , 2x34 Mb/s , STM-0, 34 Mb/s	28 MHz	32	
	8x2 Mb/s , 34 Mb/s , STM-0	14 MHz	64	
	8x2 Mb/s , 4x2 Mb/s	7 MHz	128	
	4x2 Mb/s , 2x2 Mb/s	3.5 MHz	256	
28 GHz (parts of 27.5 – 29.5) Rec. T/R 13-02 E Annex C	2xSTM-1, STM-1	56 MHz	7+4	2 – 12 km
	STM-1, 100Mb/s , 2x34 Mb/s , STM-0, 34 Mb/s	28 MHz	14+8	
	8x2 Mb/s , 34 Mb/s , STM-0	14MHz	28+16	
	8x2 Mb/s , 4x2 Mb/s	7 MHz	56+32	
	4x2 Mb/s , 2x2 Mb/s	3.5 MHz	112+64	
32 GHz (31.8 – 33.4) CEPT/ERC/REC. 01-02 E	2xSTM-1, STM-1	56 MHz	12	1 – 10 km
	STM-1, 100Mb/s , 2x34 Mb/s , STM-0, 34 Mb/s	28 MHz	27	
	8x2 Mb/s , 34 Mb/s , STM-0	14 MHz	54	
	8x2 Mb/s , 4x2 Mb/s	7 MHz	108	
	4x2 Mb/s , 2x2 Mb/s	3.5 MHz	216	

Table 6 (continued): Characteristics of frequency bands for point-to-point fixed links

Frequency Bands	Appropriate Transmission Capacity	Channel Spacings	No. of channels in the channel plan	Typical Link Length
38 GHz (37 – 39.5) Rec. T/R 12-01	2xSTM-1, STM-1	56 MHz	20	1 – 6 km
	STM-1, 100Mb/s , 2x34 Mb/s , STM-0, 34 Mb/s	28 MHz	40	
	8x2 Mb/s , 34 Mb/s , STM-0	14 MHz	80	
	8x2 Mb/s , 4x2 Mb/s	7 MHz	160	
	4x2 Mb/s , 2x2 Mb/s	3.5 MHz	320	
50 GHz (48.5 – 50.2) CEPT/ERC/REC. 12-10	34 Mb/s	28 MHz	28	< 2 km
	8x2 Mb/s	14 MHz	56	
	4x2 Mb/s	7 MHz	112	
	2x2 Mb/s	3.5 MHz	224	
52 GHz (51.4 – 52.6) CEPT/ERC REC. 12-11 E	STM-1	56 MHz	9	< 2 km
	34 Mb/s	28 MHz	18	
	8x2 Mb/s	14 MHz	36	
	4x2 Mb/s	7 MHz	72	
	2x2 Mb/s	3.5 MHz	144	
55 GHz *) (55.78 – 57.0) CEPT/ERC REC. 12-12 E	STM-1	56 MHz	9	< 1 km
	34 Mb/s	28 MHz	18	
	8x2 Mb/s	14 MHz	36	
	4x2 Mb/s	7 MHz	72	
	2x2 Mb/s	3.5 MHz	144	
58 GHz (57 - 59) CEPT/ERC/REC. 12-09	2x2 Mb/s , nx2 Mb/s	100 MHz	20	< 1 km
	2x2 Mb/s , nx2 Mb/s	50 MHz	40	

Table 6: Characteristics of frequency bands for point-to-point fixed links

(*) WRC2000 5.557A, In the band 55.78-56.26 GHz, in order to protect stations in the EESS (passive), the maximum power density delivered by the transmitter to the antenna of a fixed service station is limited to -26dB(W/MHz)

Frequency Bands	Appropriate Transmission Capacity	Channel Spacings	No. of channels in the channel plan	Typical Link Length
26 GHz (24.5 – 26.5) Rec. T/R 13-02 E Annex B	16x2 Mb/s , 32x2 Mb/s	28 MHz	32	< 5 km
	8x2 Mb/s , 16x2 Mb/s	14 MHz	64	
	8x2 Mb/s , 4x2 Mb/s	7 MHz	128	
	4x2 Mb/s , 2x2 Mb/s	3.5 MHz	256	
28 GHz (parts of 27.5 – 29.5) Rec. T/R 13-02 E Annex C	16x2 Mb/s , 32x2 Mb/s	28 MHz	14+8	< 5 km
	8x2 Mb/s , 16x2 Mb/s	14MHz	28+16	
	8x2 Mb/s , 4x2 Mb/s	7 MHz	56+32	
	4x2 Mb/s , 2x2 Mb/s	3.5 MHz	112+64	
32 GHz (31.8 – 33.4) Rec.01-02	16x2 Mb/s , 32x2 Mb/s	28 MHz	27	< 5 km
	8x2 Mb/s , 16x2 Mb/s	14 MHz	54	
	8x2 Mb/s , 4x2 Mb/s	7 MHz	108	
	4x2 Mb/s , 2x2 Mb/s	3.5 MHz	216	

Table 7: Characteristics of frequency bands for point-to-multipoint fixed links

Effective bit rate	2 E1	4 E1	8 E1	E3	STM-0	2E3	100 (3E3)	STM-1	2xSTM-1
Bandwidth	4 Mb/s	8 Mb/s	16 Mb/s	34 Mb/s	51 Mb/s	68 Mb/s	100 Mb/s	155 Mb/s	2x155 Mb/s
3.5 MHz	4 states	16 states							
7 MHz		4 states	16 states						
13.75 MHz, 14 MHz			4 states	16 states	32 states				
27.5 MHz, 28 MHz, 29.65 MHz				4 states	16 states	16 states	32 states	128 states	128 states (CCDP)
40 MHz								64 states	64 states (CCDP)
55 MHz, 56 MHz								16 states	16 states (CCDP)

Table 8: Capacity of microwave links according to bandwidth and modulation

Note1: Cross-polarisation cancellation on STM-1 systems (and higher) is used up to 13 GHz and can be used and may be used in the near future also in higher bands.

3.2 Technological requirements and trends for PP and PMP systems

The technical requirements for either point-to-point systems or point-to-multipoint systems depend on the part of the UMTS/IMT2000 network structure and the link density considered.

3.2.1 Maximising spectrum utilisation

Both Point-to-Point and Point-to-Multipoint systems may be used for UMTS/IMT2000 infrastructure. In urban and dense urban areas, both PP and PMP may be deployed efficiently. The choice between these two technologies in urban and dense urban areas may be driven by factors such as capacity requirements, traffic management, hop length, availability target, urban limitation etc.

With respect to using the limited frequency bands, the efficient use of the spectrum is a basic requirement to allow all interested network operators to deploy their own network.

It is important to note that the application of ATPC, XPIC (for SDH systems where practicable) and antennas with good RPE and improved XPD could improve the efficient use of the spectrum.

Adaptive Modulation Schemes can optimize throughput by using the highest order modulation scheme supported at any instant for the link conditions and traffic demands at the time of communication. When combined with other factors such as statistical multiplexing gains useful increases in spectrum utilisation can be realized. Adaptive modulation schemes are being considered a standard feature in the future BFWA air interface standards. It is also supported in the ETSI PMP coexistence standards. Interest in these techniques is also emerging for PP systems.

3.2.1.1 Benefits of using a combination of low and high modulation schemes in PP networks

Both 4- and 16-level systems are needed in a microwave network.

Higher modulation systems are of somewhat higher cost and are therefore most efficiently used in:

- The higher capacity systems to reduce required spectrum the most, or to fit into restricted channel bandwidths.
- Parts of network with existing or expected lack of spectrum.

A combination of 4 and 16 levels systems optimises the cost/spectrum efficiency, in a typical UMTS Network.

3.2.1.2 PMP and PP spectrum efficiency comparison

Due to the increasing needs for access transport capacities, the question whether Point-to-Point systems (PP) or Point-to-Multi-Point systems (PMP) are the most spectrum efficient solutions has been debated.

Evaluation of both single hub scenarios and network scenarios of 26 GHz PMP systems have been carried out and compared to the spectrum requirements of alternative 26 GHz as well as PP solutions with different

topologies (cascaded and star), Radio Base Station (Node B) spacings, traffic densities, antennas and design criteria. The main conclusions can be summarized as follows:

- PMP systems are spectrum efficient in regions where they can operate in capacity limited mode. That is, when most of the PMP system capacity can be utilized within the coverage area.
- For single hub scenarios, PMP is more efficient when the Node B density is high, alternative PP solutions offer better spectrum efficiency when the Node B density is low.

3.2.2 Traffic handling capability

For PP systems, the interfaces necessary for the Transport equipment are defined by the transport capacity of the node B (up to 4 x 2 Mb/s , E3) for the lub connection, 34 Mb/s , 2 x 34 Mb/s or n x STM-1 where higher transport capacities e.g. for lur connections are needed.

For PMP systems the issue of capacity is complicated further by the area coverage considerations. PMP central stations can transport up to 130Mb/s /28 MHz in any sectorized coverage area per channel of operation. Multiplexing gains would increase the potential to allocate this resource to a number of nodes within the coverage area.

Even if data traffic is increasing having symmetrical and asymmetrical characteristics the voice traffic will be important. Thus the equipment has to transport the different types of information efficiently by providing a possibility to transport the maximum capacity needed in time for the connection considered with the appropriate grade of service.

However, the nature of traffic could change. A change from predominant voice services to data services is possible which may impact the nature of the traffic to be transported. PMP systems should have the flexibility to cater for these changing requirements by either adapting the uplink / downlink modulation scheme or the ratio of the transmission time resource between uplink and downlink.”

3.2.3 Transport mechanism

It is reasonable to assume that the transport mechanism will be based on ATM.

Until now the transmission interfaces are mainly based on well known PDH and SDH interfaces, such as E1, E3, STM-0 and STM-1, taking more or less the benefits from the ATM Adaptation Layers (AAL 1 for CBR GSM traffic, AAL 2 and AAL 5).

With future UMTS releases this might change and has to be observed that the Ethernet and/or other interfaces might become more common.

3.2.4 Planning microwave transmission, availability and quality

Traditionally operators have deployed their mobile backhaul networks based on a combination of point-to-point microwave and leased lines. The main deciding factor in the choice between microwave and leased lines is the individual operator's needs in terms of network control and transmission quality.

Typical leased line contracts have often guaranteed availability figures around 98.7% corresponding to potential downtimes of four to five days per year. Microwave networks (i.e.: the connections between the Node Bs and the TCP and/or Node A) are dimensioned for 99.95% availability or higher, corresponding to four hours per year.

For this availability objective, microwave links are suitable for ATM and IP transport. In conclusion, the availability of a microwave network is very much a planning issue. By selecting high quality products in combination with a proper network planning, the availability is normally the same or higher than fiber or copper networks.

3.2.5 Protection

The end-users traffic is the most important asset for the operator. If the service delivered is not reliable, end-users will change their service provider. High quality equipment complemented with additional protection mechanisms provides the operator with the means, necessary to deliver high-quality services.

Wireless links must include protection towards equipment failure as well as towards radio propagation anomalies. Hardware is duplicated to support the protected configurations on either or both of the two sides of the radio connection. The transmitting equipment can be configured either for hot stand-by transmission mode or as working stand-by transmission mode.

An aggregation node shall add another level of protection i.e. network protection. This functionality enables the operator to build reliable ring structures based on any microwave capacity up to 155 Mb/s . The ring protection mechanisms works on E1 level, and it allows protection of all or pin-pointed E1's within the total payload.

3.3 Link density

According to the calculation method and the example given in ECC-Report on „methodology to determine the density of fixed service systems” highly directional antennas should be used to increase the density. Therefore in dense networks, antenna pattern based on Recommendation ITU-R F.1245 or Class 3 antenna pattern given in ETSI standard ETS 300 833, should be favoured.

Using different polarisations allows a significant increase in density of terminals (taking into account the cross polarization of the antenna and applying the rule that links with hop lengths of more than 3 km use the vertical polarisation).

To derive more realistic results other parameters should be taken into account such as ATPC or influence of adjacent or nearby channels.

To increase the density of terminals in dense network deployment higher threshold degradation could be accepted (e.g. for dense network deployment), if performance and availability objectives can still be met and increased degradation can be compensated in the link budget. Therefore two options need to be considered to satisfy the need for dense network deployment:

- Decreasing the C/I;
- Acceptable threshold degradation - based on national planning requirements or as defined in ECC Recommendation (01)05 on “List of Parameters of Digital Point-to-Point Fixed Radio Links Used For National Planning” - should be determined on a case by case basis.

3.4 Comparison of the topology and the band characteristics

This section compares the network topology given in section 2 and the band characteristics described in section 3.1 as well as the other influencing factors described in section 3.4.2 below in order to allow for a dedication of frequency bands to specific parts of the UMTS/IMT2000 network.

3.4.1 Comparison of the topology and band characteristics described in section 3.1

Tables 9 and 10 below provide a list of the generally most appropriate frequency bands for accommodating wireless links, employed at different network layers of UMTS/IMT-2000 infrastructure network.

They only take into account the band characteristics and existing equipment in the band and do not take into account any other factors which could have a significant impact on the availability and appropriateness of the bands. These factors are considered in **Table 11** in **section 3.4.2**

Network Layer	Frequency bands	Preferred frequency bands for shorter haul (urban)	Preferred frequency bands for longer haul (rural)
Single Node B	13-58 GHz	32-38-52-55-58 GHz	13-15-18-23-26-28-32 GHz
Node B --> TCP	11-55 GHz	26-28-32-38-52-55 GHz	11-13-15-18-23-26-28-32 GHz
TCP --> Node A	11-38 GHz	26-28-32-38 GHz	11-13-18-23-26-28-32 GHz
Node A--> RNC	4-32 GHz	13-18-23-26-28-32 GHz	4-L6-U6-7.5-11-13-18 GHz
RNC --> MSC/SGSN	Up to 18 GHz	13-18 GHz	Up to 18 GHz

Table 9: Possible dedication of frequency bands for PP systems depending on the layers of the network

Network Layer	Possible frequency bands
Single Node B	26-28-32 GHz
Node B --> TCP	26-28-32 GHz
TCP --> Node A	N/A
Node A--> RNC	N/A
RNC --> MSC/SGSN	N/A

Table 10: Possible dedication of frequency bands for PMP systems depending on the layers of the network

3.4.2 Other factors to be taken into account when considering bands for the UMTS/IMT-2000 infrastructure

When considering bands for the UMTS/IMT-2000 infrastructure many other factors have to be taken into account such as sharing issues with other radio services, spectrum congestion due to existing assignments, etc. some of these aspects are summarised in Table 11.

Band	Limited Capacity	Potential for sufficient further assignments in most countries	Assignments exist or planned			Other services	Sharing Comp.	Comments
			2G	FWA	Other FS			
3.4GHz	X			X		X	Radiolocation	
4GHz		X			X		FSS, ESV	coordinated FSS
L6GHz		X	X		X		FSS, ESV	coordinated FSS
H6GHz		X	X		X			
7/8GHz	X		X		X	X	Military	Different Plans
10.5GHz	X			X	X	X	Military	
11GHz		Note 1			X	X	DTH	ERC-Decision
12GHz	X				X	X	DTH	ERC-Decision
13GHz		X (already saturated in some areas)	X		X		FSS	coordinated FSS
15GHz	X	X (already saturated in some areas)	X		X		Military in some countries	coordinated FSS
18GHz		X	X		X	X	FSS	ERC-Decision
23GHz		Note 2	X		X	X	Passives Services	
26GHz		Note 2	X	X	X			
28GHz		X	X	X	X	X	FSS	ERC Decision
32GHz		X	X	X	X	X	Radionavigation, Passive Services	
38GHz		X Note 2	X		X			ERC Decision
48GHz		Note 3			X		EESS (passive), SR (passive)	
52GHz		Note 3					Passives Services	
55GHz		Note 3					Passives Services	
58GHz		Note 3			X	X	Passives Services	uncoordinated FS

Table 11

Note 1: Decision ERC/DEC(00)08 indicates that new fixed service systems deployment is to be limited to high capacity (140 Mb/s or higher) point to point fixed links (trunk network only) and that CEPT administrations shall to the extent practicable, take measures to protect uncoordinated FSS terminals from new fixed links.

Note 2: These are the bands heavily used for 2G infrastructure.

Note 3: Due to the propagation condition, in these high mm-bands, the hop lengths would be short (see *table 6*). Therefore, the network layers for which these bands can be used is already determined.

3.5 Upgrade of existing 2G links into 3G links

The introduction of 3rd Generation and the services that 3G can provide are not likely to be supported by existing networks when available. Therefore, the capacity requirements compared with 2nd Generation or 2.5G that is typically offered today, will necessitate an upgrade of current PP links that support GSM-900/1800 networks.

The subsequent sub sections consider the practical difficulties in relation to upgrading existing PDH links to SDH with the associated increased propagation availability requirement (>99.99%) within the same frequency band. A possible upgrade path is offered with particular emphasis on the spectrum allocations that are necessary to support the upgrade.

3.5.1 Evolution of 3G networks

Current GSM networks have been heavily reliant on PP radio infrastructure to link up the MSC – BSC – BTS. The vast majority of links are PDH with capacities of E1 – 16E1 and the most popular frequency bands used have been 23 and 38 GHz, these bands have been used for hop lengths between <1 Km – 15 Km.

To support the services of 3G it is anticipated that the data traffic capacity will increase to the extent that can not be carried by the current 2G infrastructure, particularly in the urban areas of the network. For PDH links that are currently carrying a capacity of 8E1/16E1 it is anticipated that a high proportion of these links will migrate up to SDH capacities, particularly STM-1. It should also be noted that PDH links deployed were planned with a propagation availability of 99.99%. For SDH links the availability will increase to a minimum of 99.995%.

An example of the traffic estimation for links to an individual base station (Node-B) is shown in Figure 18. The mobile traffic on which the above estimation is based includes high-quality speech, high-speed packet and medium/high multimedia signal transport. In the long term it is assumed that required capacity to an individual station will increase about 4 times compared to that for the 2nd generation system in terms of 90% cumulative value

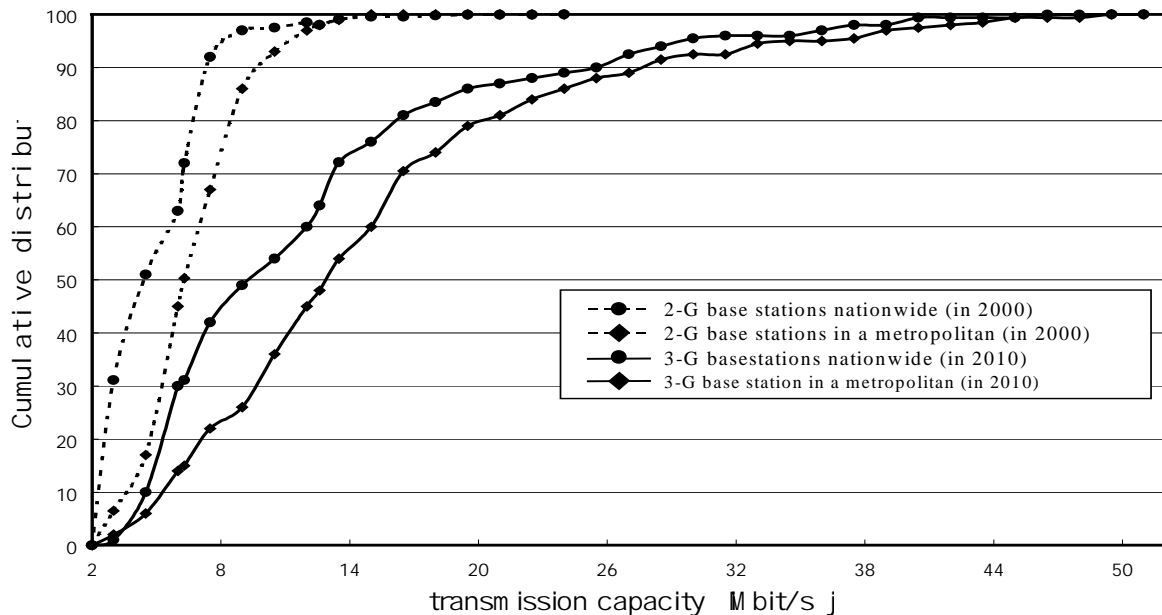

Figure 18: Example of traffic estimation for links to an individual Node B

3.5.2 Technology limitations

Current technology limits the overall system gain of SDH STM-1 as compared to an existing PDH capacity. This will impact on the maximum achievable link length for a PP link in a particular frequency band. Ideally the operator preference is to upgrade a PDH link to SDH in the same frequency band. However where the current

PDH link has been deployed towards the maximum achievable link length for the band it is not possible to remain in the same band for the upgraded SDH link.

In addition, for cost/spectrum efficiency reasons, the increase density of Node Bs could require to replace some of the existing PP with PMP links. It is noted however that PMP architecture may not always be possible within an existing network due to line of sight constraints. The nodal point where the base-station is to be located may not necessarily be in the optimal position.

3.5.3 System Gain

Using current ETSI standards and an example of equipment designed today the effect of system gain is detailed below.

Capacity/Bandwidth	Typical O/P Power	**System Gain (dB)	“lost” System Gain (dB)
*PDH 8E1/14 MHz	+17 dBm	94.5	-
PDH 16E1/28 MHz	+17 dBm	91.5	-3
***STM-1/28 MHz	+17 dBm	79	-15.5
***STM-1/56 MHz	+18 dBm	84.5	-10

Table 12: System Gain at 23 GHz

* ETSI Class 2 (4 level modulation)

** Referenced to a BER of 10^{-6}

*** Assumed non-protected link

Capacity/Bandwidth	Typical O/P Power	**System Gain (dB)	“lost” System Gain (dB)
*PDH 8E1/14 MHz	+16 dBm	89.5	-
PDH 16E1/28 MHz	+16 dBm	86.5	-3
***STM-1/28 MHz	+15.5 dBm	74	-15.5
***STM-1/56 MHz	+15 dBm	77.5	-12

Table 13: System Gain at 38 GHz

* ETSI Class 2 (4 level modulation)

** Referenced to a BER of 10^{-6}

*** Assumed non-protected link.

The loss of system gain can be measured in terms of maximum distance achievable for a given capacity and a given frequency band. In the higher frequency bands the loss of system gain has a profound effect on the maximum hop length that can be achieved.

Increasing the antenna dish size is an engineering solution to recover some of the “lost” system gain, however there is an environmental impact to larger dish sizes that may not be tolerated by local planning committees. In addition there is the possibility that current tower structures cannot support the additional antenna size due to wind loading constraints.

It should be noted that this measure could impact on other FS link assignments as well as on compatibility with other services sharing the same band, such as the passive service and would therefore have to be taken into account in link planning.

At the initial stage of the UMTS/IMT-2000 deployment, it is efficient, economical and environmental to commonly use the site with the 2-G system. This means that 3-G base stations are overlaid to those of the 2-G systems utilising the same locations. Also in such cases, required capacity for radio access network will be notably increased by conversion from the 2-G system to the 3-G system.

It is apparent that in order to allow existing PDH links to upgrade over the same path other frequency bands need to be considered. 3G networks will evolve from existing GSM networks and so it is impractical to expect a total redesign of the network in the initial stages of development.

3.5.4 Location Sharing

As higher layer links can transport lower network traffic, an MSC station can accommodate RNCs. The same relation could apply to RNC and Node-A. Location sharing by Node facilities with different layers brings about advantage of efficient maintenance and operation.

In a wide and high-density metropolitan area, several MSCs are needed, RNCs could also be concentrated to the same building as MSCs. Thus on account of the reduced hierarchy, configuration of the networks will be simplified as shown in Figure 19.

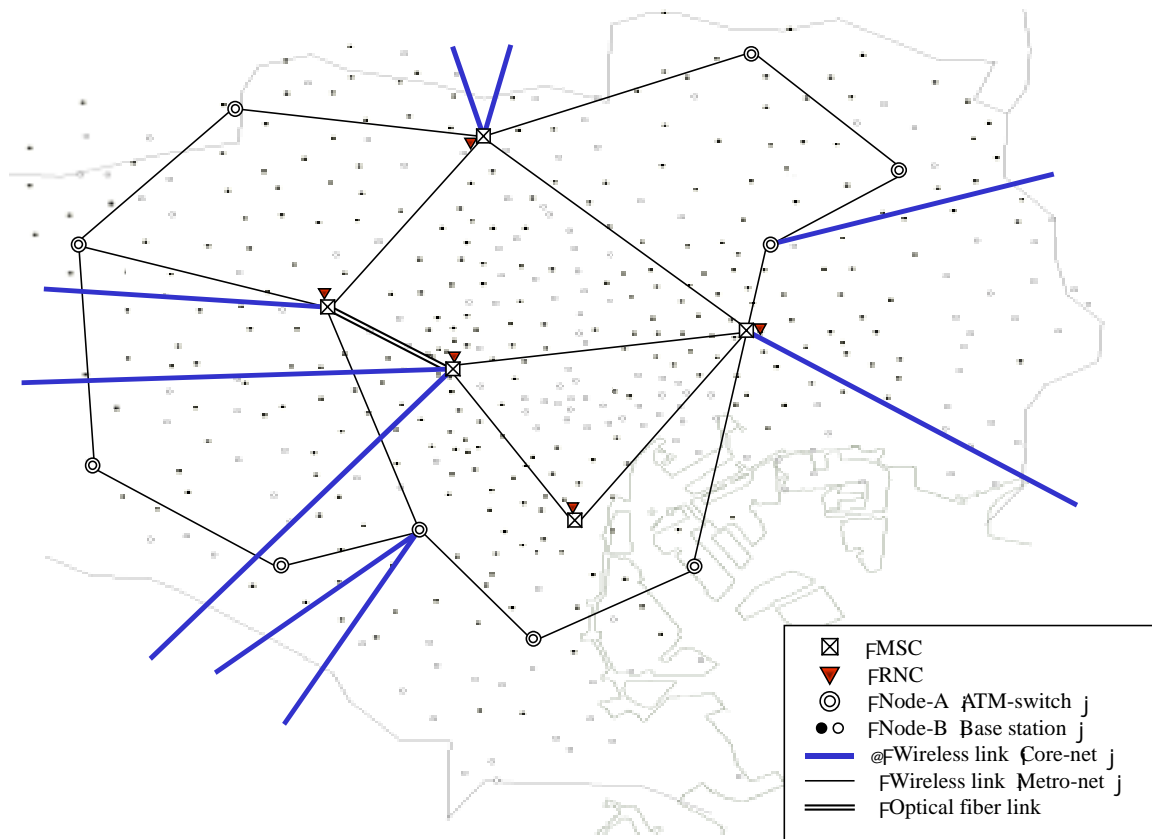

Figure 19: Example of a Configuration of the UMTS/IMT-2000 transport and radio access networks in the metropolitan area

3.6 Infrastructure sharing between 3G operators

Where allowed or encouraged by the National Regulatory Authorities (NRA) the infrastructure sharing between mobile operators would be very advantageous.

A single TCP or a Node A can collect the traffic from the Node Bs of a particular area regardless of the operator they belong to. This solution would certainly provide several benefits, by strongly reducing the required number of sites, in terms of:

- Visual impact
- System cost
- Spectrum utilisation. Mainly when, in conjunction with ATM based PMP system, the granularity gain and the statistical multiplexing are exploited.

In practice there could be one or more “third party” operator offering the mobile infrastructure service (possibly together with the business access service) to the mobile operators, provided that the allocated frequency block is appropriately large.

4 FREQUENCY ASSIGNMENT ASPECTS

4.1 Conversion of 2G infrastructure assignments into a combined 2G/3G infrastructure network

Existing FS link assignments used in 2G mobile infrastructure networks could be converted for the usage within a combined 2G/3G infrastructure network, at least for operators which provide 2G and 3G services. Nevertheless a direct conversion of existing 2G infrastructure assignments could be very difficult (sometimes even impossible). The capacity demands for a combined network will increase significantly and it may be that in the frequency bands where the actual assignments exist the frequency spectrum is congested.

This implies the need of new FS spectrum for combined 2G/3G networks. In the medium-to-long term an upgrade of the old assignments towards the required higher capacity demands are maybe possible in the old bands. Depending on the national situation a complete shift of the assignments to new bands at least in the dense areas would then be favourable for upgrading 2G to a combined 2G/3G network. The spectrum released in these “old “bands might be available for the use of various high capacity applications (both mobile and fixed network related).

Nevertheless the possibility to apply for new link-by-link frequency assignments in rural areas, could enable the reuse of existing microwave equipment. Figure 20 shows how frequency requirements will evolve:

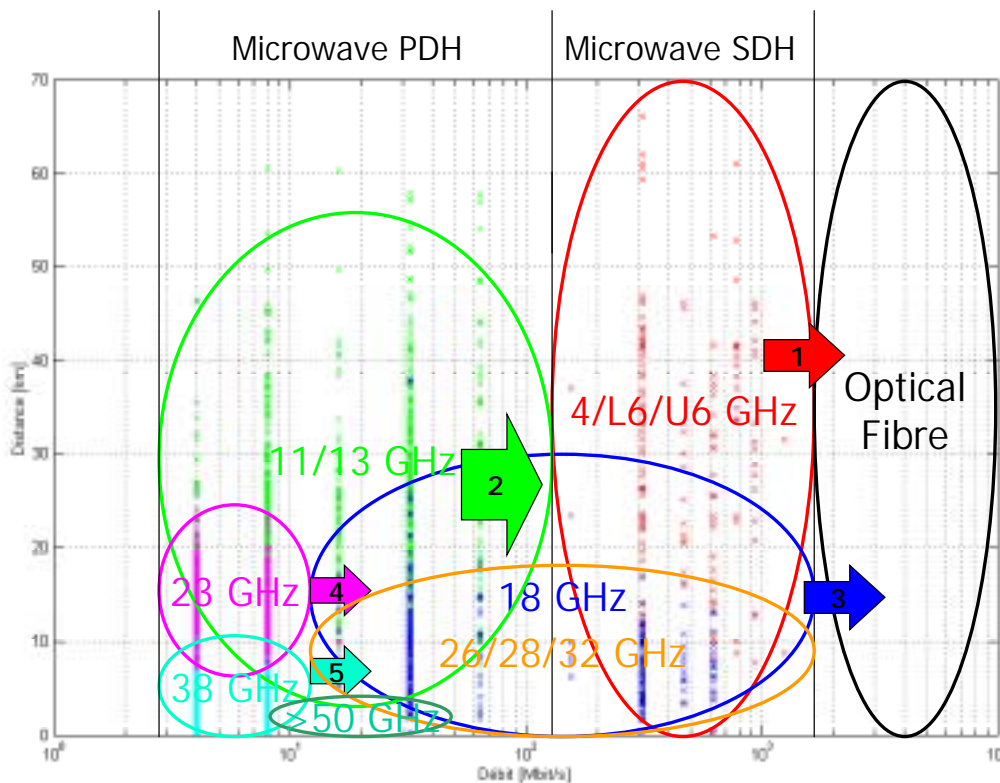

Figure 20: Evolution of frequency requirements

Generally speaking, the arrival of high capacity mobile data services will cause a shift towards the right (higher bit rates).

4.1.1 Possible changes in core network frequency requirements

- **L6/U6 GHz band:** the 6 GHz band will continue to be heavily used for regional SDH loops. Part of the regional SDH loop will be established using optical fibre but, locally, it may still be necessary to use additional channels in other frequency bands such as the 4 GHz or 7/8 GHz bands.
- **13 GHz band:** with the arrival of UMTS/IMT-2000, a very large number of 34 Mb/s links within the 13 GHz band might become saturated. In order to cope with this increase in traffic, it would be essential to use another frequency band with equivalent conditions of propagation, or to authorise the use of SDH links with 28 MHz channelisation, which could allow the bit rate of many existing links to be quadrupled.
- **18 GHz band:** the 18 GHz band is essential for urban SDH links and connecting sites to the optical loop in rural areas. This band is also very important for medium bit rate (PDH) links. Furthermore, the 18 GHz band might be used to relieve the 13 GHz band and absorb part of the predicted increase in traffic on the 23 GHz band.

4.1.2 Possible changes in access network frequency requirements

The bit rates required in the access network will quickly increase with the arrival of new high capacity mobile services. The resulting frequency requirements can be estimated by means of network simulation assuming different volumes of traffic Node B in an urban area.

Several solutions are envisaged for coping with this increase in capacity of the local loop:

- **The use of more efficient modulation** such as 16-QAM; the reduction in the maximum allowable hop distance remains acceptable in densely populated urban areas;
- **The use of increased bandwidths** (14 MHz, and 28 MHz) in the existing 23 GHz and 38 GHz frequency bands;
- **The use of new frequency bands between 23 GHz and 38 GHz:** given the current occupancy of the 23 GHz and 38 GHz bands, it will be difficult to accommodate the additional frequency requirements in these two bands. The minimum frequency needs within the frequency bands between 23 GHz and 38 GHz can reasonably be estimated at 2x112 MHz per operator;
- **The use of new frequency bands above 50 GHz:** The very short links between pico-cells could be established within frequency bands above 50 GHz, such as the 52 GHz, 55 GHz or 58 GHz bands.

4.2 Block assignments/Inter-operator protection measures

The necessary Node B density in metropolitan areas determines the spectrum requirement of fixed service links for UMTS/IMT-2000. In the first years of UMTS/IMT-2000 deployment there is likely to be a significant requirement of Node B mainly in dense areas. E.g. in Germany for 50% population coverage (8.5 % of the area) around 10.000 Node B are required per operator. In the first step this network rollout should be finished as soon as possible. In a second phase a further 10.000 to 20.000 Node Bs will be required in order to extend coverage to certain rural areas and upgrade capacity rollout in dense areas. In order to support the demand of a quick Node B rollout and the necessary FS infrastructure a fast assignment procedure is required. This can be achieved by various means:

- Computerised link by link assignment with quick response from the regulator
- Block assignment
- Combination of the above mentioned methods

The majority of wireless links for UMTS/IMT-2000 Node B access are characterised as low and medium capacity with short hop distances. Taking into account the large number of links that will be required, block assignment procedures appear to be a viable way to allow a quick assignment for those administrations with limited resources. Due to the characteristics of such links, the block assignments can be favourably used in bands above around 20 GHz, depending on the national availability and frequency planning procedures.

4.2.1 Advantages and disadvantages of block assignments

Advantages of block assignments are:

- Fast rollout.
- Spectrum efficient planning on the basis of typical system parameters.
- Spectrum efficient planning by acceptance of possible interference from own systems.
- Cost effectiveness with regard to spare part handling and contracting.
- Technology independent (PP and PMP could be used equally, but for PMP the only sensible solution).

Beside the above mentioned advantages also risks and disadvantages may appear:

- High/Low conflicts
- Unused spectrum due to guard bands (leading to spectrum inefficiency)
- Unused block allocations (leading to spectrum inefficiency)

4.2.2 Inter operator protection measures in block assignment scenarios

4.2.2.1 Example assignment scenario with guard band

If block assignment procedures are applied, guard bands should separate these spectrum assignments to avoid interference between the different operators, see Figure 21. Within the assigned blocks the operators can freely choose polarisation and channel bandwidth up to maximum usable bandwidth (i.e. 28 MHz).

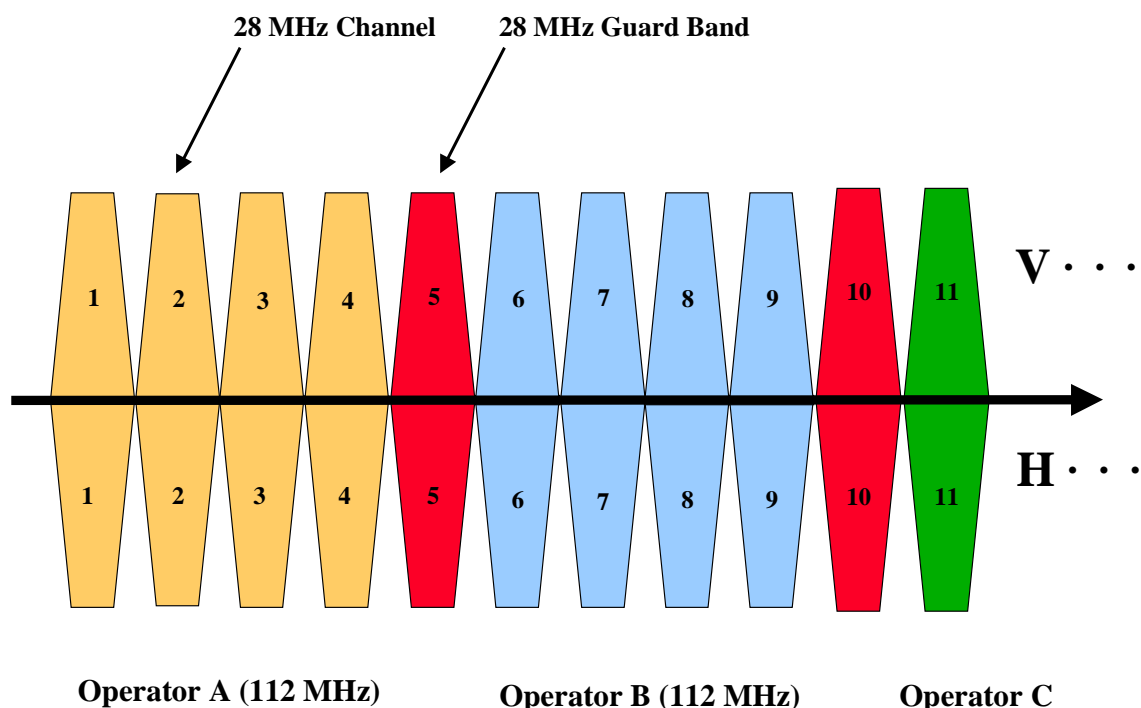

Figure 21: Example of block and guard band assignment

To avoid the mentioned risks in section 4.2.1 certain measures have to be applied. To avoid high/low conflicts, at least for central station sites in star configurations a certain sub-band may be defined in advance for PMP – usage (i.e. TCP with more than 3 links per band).

In conjunction with sufficient guard bands less conflicts may appear or conflicts could be avoided at all if the positions of large central station sites are coordinated between the operators with neighbouring frequency blocks. From experience in GSM-networks the transmission departments of the different operators are in a relatively close contact and kept informed of important nodes of the operators. The administration may also consider providing a web accessed database with Hi/Lo site details based on Lat/Long co-ordinates. This method has been adopted by the ODTR (Ireland) and the RA (UK).

To minimise the guard bands, the block size should be adequate and should not be less than 56 MHz within a band. However, 84 MHz or 112 MHz are more suitable but may be sometimes difficult to implement. Since the guard band should be in the size of the maximum usable channel bandwidth, the maximum useable channel

bandwidth for the operators has to be limited, at least at the edges of a block. After the main rollout is complete, the guard bands could be used by operators for optimisation purposes if frequency planning is applied between the operators. In this respect the guard bands are not wasted, the use is just delayed until the completion of the major rollout. Only at the border of PMP and PP usage there is relatively little possibility to find a suitable solution.

To secure an efficient use of the bands and to avoid denying spectrum an information should be sent to the authority by means of e.g. monthly or yearly reports. Unused or insufficiently used spectrum could be made available for other operators or applications later on.

If the regulator allows, the operator could have the freedom to decide to operate either of or both PP and PMP systems in the allocated spectrum. To avoid interference between operators, the guidelines described in the relevant CEPT Recommendations could be applied independent of the used band.

To allow the mixed use of PMP and PP systems by different operators, see Figure 22, the maximum bandwidth of PP systems at the edge of a block should be limited to half of the guard band between two operators, if one uses PMP. Furthermore it would be beneficial to concentrate operators that intend to use a certain technology in separated parts of the band.

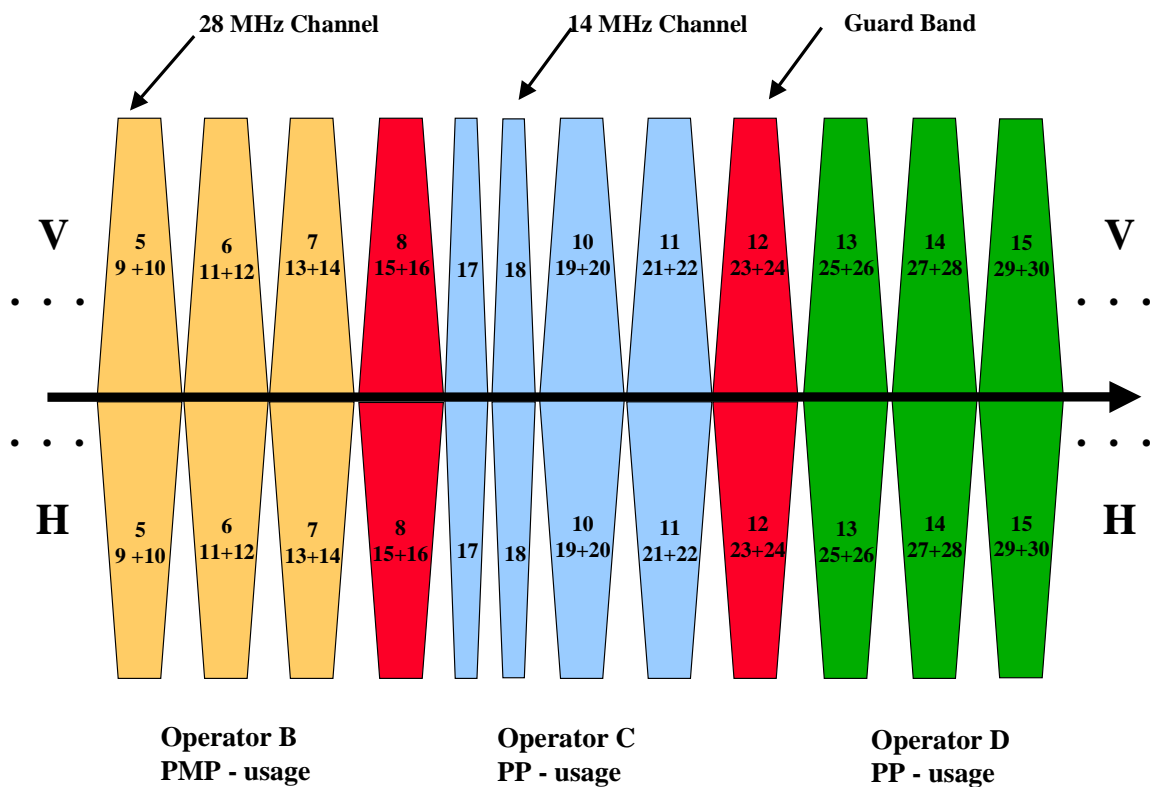

Figure 22: Example of guard bands between operators in the case of PP and PMP in the same area

4.2.2.2 Example assignment scenario without guard band

The assignments mentioned in the previous Section 4.2.2.1 would provide enough protection for inter-operator interference in the initial rollout. Another example possibility is given in Figure 23.

This assignment example has the following advantageous features:

- 4 RF channels are accommodated within 4xX MHz bandwidth assigned to one operator;
- adjacent RF channels between two operators (e.g. channels #4 and #5) are arranged in different polarizations, and this will contribute to reduction of the inter-operator interference;

- one operator could use his channels from the lower frequency (e.g. channels #1 and #2) utilizing a single polarization antenna, then afterwards increase the link capacity by employing either the opposite polarization feeder or separate antenna with the opposite polarization.

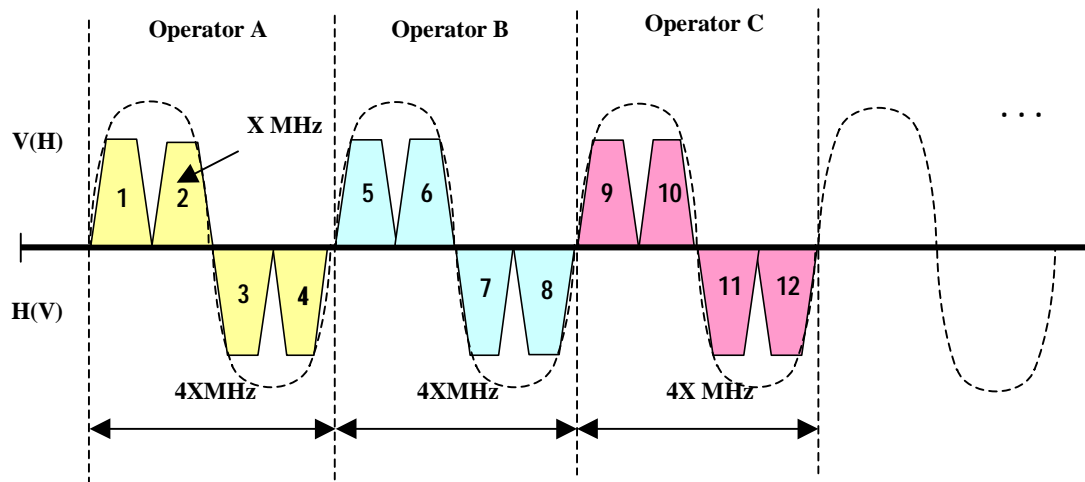

Figure 23: Example of interleaved assignment without guard band

The assignment in Figure 23 has certain similarity with that used for transport networks requiring higher capacity. The spectrum illustrated within the dotted-line in Figure 23 indicates an interleaved arrangement with $2 \times X$ MHz spacing, which could be used for up to STM-1 transmission. Thus, harmonised spectrum management could become possible between base station back-haul links and long/short-haul transport networks.

4.2.3 Norwegian block assignment policy

Before the deregulation of telecom infrastructure in 1996, all fixed links were operated by Telenor, offshore companies in the North Sea, and Statnett. Statnett is the Norwegian Transmission System Operator, operator of the Norwegian electric power backbone system.

With the deregulation, the demand for fixed link frequencies rose. Because of the large demand and the limited resources in the PT at that time, it was decided to allocate frequency blocks to the new operators on a "First come, first served" basis. The PT is self-financed, primarily through fees and charges. Therefore, there is a balance between the resources that may be spent on the regulation of the frequency bands, and the consequences of different alternatives of frequency allocation.

Frequency blocks have been allocated in the 23, 26, and 38 GHz bands. Later, the demand for spectrum turned towards PMP, and the allocation of frequency blocks for fixed links was stopped. Further blocks may be allocated later.

Rules applied in this licensing regime are as follows:

- The licenses are given without very strict technical regulations. The operators are responsible for any interference caused by their systems. If a conflict should occur between two operators, the operator who put his system into service first, has the priority.
- At the end of each year, the operators must send the PT detailed information of the links that have been established.
- At any time, the utilisation of the spectrum allocated to an operator may be evaluated. If the PT considers that there is no need for a whole frequency block, the license for the block may be withdrawn, and replaced by individual licenses.

4.2.4 Link by link assignment procedure in the UK

The fixed link assignment system, a noise limited system that has been developed by the UK Radiocommunications Agency, is efficient in meeting the demands of customers. The assignment system is updated with the relevant frequency assignment criteria that are in line with ETSI and CEPT standards and recommendations and agreed with UK industry prior to opening FS bands for civil use. The assignment of all fixed service bands for point to point use that are administered by the RA are fully incorporated into the assignment system and all assignments are made on a link by link basis.

In the license application, the customer provides details of the preferred sites as well as technical characteristics of the required link e.g. equipment, polarisation, availability.

Prior to assigning the link, the application is validated by the system, which checks whether:

- sites are identifiable or known, create new sites if required
- Hi/Lo configurations are appropriate and LOS
- antennas used are approved for the band according to manufacturers' specifications
- approval of equipment for the band
- link lengths are appropriate.

In most cases with the exception of 58 GHz, channels are assigned in the highest frequency band compatible in order to meet the radio planning requirements. If the application is valid, further technical checks are carried out including:

- correct antenna elevations and azimuths
- whether the required availability is greater than 99.99%

After this verification process, the assignment routine identifies the terrain type around and in between link ends e.g. rural, urban, water, wood etc and the Fresnel Zone clearance, fade margin and the required EIRPs are calculated.

The assignment process next identifies all links in the same band within the co-ordination zone. A channel/range of channels are then selected by the assignment engineer from all the channels available. All interference signals from and to every other user within the co-ordination zone is calculated and assessed for interference potential. The first available interference free channel is then assigned. This system can be manually overridden for special cases.

The RA will initially assign provisional frequencies for each link, following co-ordination with existing fixed (point to point) terrestrial links and other services. Notification of provisional frequencies does not give authority to operate the fixed (point to point) terrestrial link but is provided to assist the applicant with early equipment procurement and configuration. The licence is only formally issued when all clearances have been received with confirmations from all interested parties

4.2.5 Conclusion

It should be noted that between a totally exclusive use of block assignments and a link by link assignment policy there are various possible solutions. A block assignment procedure can be useful for the lower layer of the UMTS/IMT-2000 infrastructure network in frequency bands above around 20 GHz. Depending on the number of UMTS/IMT 2000 operators, it could be beneficial to allow the exclusive use of the relevant part of the spectrum only for a certain timeframe until the major network rollout is completed and reconsider this situation afterwards.

For the upper part of the network layers (above Node A), where less links with high capacity demands (STM-1 and more) will be likely, a link-by-link assignment procedure seems to be more appropriate.

5 CONCLUSIONS

Due to the different national situation within CEPT countries, it is not possible to provide a single answer for the amount of spectrum required for wireless links to be used in infrastructure of the UMTS/IMT-2000 networks, or in which bands spectrum for this purpose should be provided.

These decisions will have to be made on a national basis, taking into account the following principles:

- The required total bandwidth for UMTS/IMT-2000 infrastructure networks will be determined in the longer term only, depending on the success of UMTS/IMT-2000. These requirements should be

oriented towards a medium-term solution, that allows sufficient planning certainty for the operators in terms of economical aspects and a fast roll out of the UMTS/IMT-2000 network taking into account the spectrum efficiency and requirements of other services and applications.

- Although the required amount of spectrum and the absolute numbers of wireless links will be different for the various countries and operators, the link densities in the urban areas are likely to determine the total required FS spectrum for infrastructure networks of UMTS/IMT – 2000.
- Using the information in this report, the required FS spectrum could be estimated for the different layers of the UMTS/IMT-2000 infrastructure network for a typical operator with 2 - 3 UMTS/IMT-2000 frequency blocks (i.e. 10-15 MHz UMTS/IMT-2000 - spectrum with 5 MHz for each block). The requirements could be adopted by administrations to the national needs in terms of:
 - Number of operators;
 - Market aspects;
 - Future density of the wireless infrastructure links of the networks;
 - Use of alternative networks to provide infrastructure (e.g. cable or fiber optics);
 - Climatic and topographic situation;
 - Regulatory policy;
 - etc.
- When considering which bands would be best suitable for the UMTS/IMT-2000 infrastructure and the following consideration regarding the availability and appropriateness of a given frequency band should be taken into account:
 - Technical characteristics in terms of achievable data rates, hop length, etc.
 - sharing issues and/or split of the band and/or priorities given to various radio services (relevant ERC REC/ERC Decisions apply),
 - spectrum congestion due to existing assignments,
 - etc.
- With regard to the most appropriate frequency assignment procedure the necessity for a fast and flexible roll out of the infrastructure network has to be considered requiring the
 - Fast and flexible provision of spectrum for PP and MP system with an appropriate assignment strategy,
 - Incorporation/upgrade of existing infrastructure networks (e.g. 2G into 3G) if appropriate and possible,
 - Possible sharing of infrastructure if appropriate and possible.

Annex 4 provides an example calculation method to derive the spectrum requirements for particular layers of the network (Node B and TCP layers).

Annex 5 provides an example for the spectrum requirement for a typical sub-network structure as described in section 2 of this report.

ANNEX 1

Market scenarios of UMTS/IMT-2000 networks

The application of the market forecast methodology described in Chapter 2 is illustrated for UMTS/IMT-2000 networks in the developed countries in Region 1.

The example calculates the offered bit quantity (OBQ) for up- and down-links in the year 2010 based on the market forecast of Region 1, provided by ITU-R Rec. M.1390. However ITU-R Rec. M.1390 is focused on the calculation of spectrum requirements and does not provide information of the market in suburban, rural and sparsely populated regions. Thus, the following assumptions have been made, in order to get the full picture required capacities in 3rd generation mobile networks:

- population density in suburban areas is 7.5 % of the urban pedestrian environment,
- population density in rural areas is 0.5 % of the suburban environment,
- population density in remote and sparsely populated areas is 2.5% of the rural environment,
- penetration rate per service, busy hour call attempts, activity factor and call duration of suburban, rural and remote areas are the same as in the urban vehicular environment,
- the total OBQ in urban areas is the aggregation of vehicular and pedestrian capacity requirements,
- the total OBQ in central business districts (CBD) is the aggregation of urban (vehicular and pedestrian) and the in building requirement as well.

Other market scenarios or significantly different assumptions may lead to significantly different results.

It should be noted that the model assumes, that no user occupies two operational environments at the same time. Additional operating environments such as aeronautical (telecommunication to subscribers who are passengers on board a moving aircraft), vehicles with mobile base stations (telecommunications to pedestrian subscribers in a bus or a train) and all satellite environments, are left out in this estimation.

Since a multiple operator environment shall be considered, the cell areas in the different implementations of UMTS/IMT-2000 are of less importance. Depending on network concepts and market shares of the operators physical cell sizes will vary. Thus, all capacity considerations have be focused on the full IMT-2000 market to achieve to most flexible approach. The corresponding capacities will be referenced to the area of one km².

Operational environments	Potential users/km ²
High density in building (CBD)	250 000
Urban pedestrian	100 000
Urban vehicular	3 000
Suburban in building or on street	7500
Rural in- and out-door	38
Remote area, sparsely populated	1

Table A1-1: Population density in different operational Environments

The penetration of users per service is given in Table A1-2 for year 2010, presented for each service. It is assumed that the penetration will be the same in all environments under consideration.

Service	Penetration in %
Speech	73 %
Simple Messaging	40 %
Switched Data	13 %
Medium Multimedia	15 %
High Multimedia	15 %
High Interactive Multimedia	25 %

Table A1-2: Penetration Rate per Service in Percent, Year 2010

It should be noted that the use of each service is not exclusive. Each penetration figure refers to the penetration of this service as a proportion of the total potential user base. Since users can use more than one service it is possible for the total penetration in an environment (across all services) to exceed one (100%) if a high proportion of users are using more than one service.

The CBD (Central Business District) environment is assumed to be the only environment with offices. This means that the penetration in CBD area comes primarily from people in those offices.

The expected busy hour call attempts are given in Table A1-3.

Service	Environment			
	High density in building CBD	Urban pedestrian	Urban vehicular	Suburban, Rural and Remote in- and outdoor
Speech	0.9	0.8	0.4	0.4
Simple Messaging	0.06	0.03	0.02	0.02
Switched Data	0.2	0.2	0.02	0.02
Medium Multimedia	0.5	0.4	0.008	0.008
High Multimedia	0.15	0.06	0.008	0.008
High Interactive Multimedia	0.1	0.05	0.008	0.008

Table A1-3: Busy Hour Call Attempts, expressed as calls in busy hour

The activity factor and call duration in the services under consideration is given in table A1-4, expected to be applicable to the year 2010 and all environments, for both up- and downlink.

	Activity Factor	Call Duration
Speech	0.5	120
Simple Messaging	1	30
Switched Data	1	156
Medium Multimedia	1	13.9
High Multimedia	1	53.3
High Interactive Multimedia	0.8	180

Table A1-4: Activity Factor and Call Duration in seconds

The user bit rates according to throughput, coding factor and symmetry is given in Table A1-5. The coding factor is a generalised measure of the degree of coding required to transport the service to the required quality. This is separate from the signalling requirements.

Services	User Bit Rates	
	Downlink (DL), kb/s	Uplink (UL), kb/s
Speech	16	16
Simple Messaging	14	14
Switched Data	64	64
Medium Multimedia	384	64
High Multimedia	2000	128
High Interactive Multimedia	128	128

Table A1-5: Service types and corresponding user bit rates

High and medium multimedia and simple messaging services correspond to packet based services such as WWW. It is assumed that these services will have a different service bandwidth in the uplink and downlink except for simple messaging.

The results of the OBQ example calculation based on UMTS/IMT-2000 market forecast provided by ITU-R Recommendation M.1390 are given Tables (A1-6A to A1-6B) representing the following scenarios during the busy hour:

- Down Link capacity in 2010 (Table A1-6A)
- Up Link capacity in 2010 (Table A1-6B).

Services	Environment					
	CBD	Urban pedestrian	Urban vehicular	Suburban	Rural	Remote
Speech	43.8	15.6	2.4×10^{-1}	1.2	3.0×10^{-3}	7.8×10^{-5}
Simple Messaging	7.0×10^{-1}	1.4×10^{-1}	2.8×10^{-3}	1.1×10^{-2}	3.5×10^{-5}	9.3×10^{-7}
Switched Data	18.0	7.2	2.2×10^{-2}	5.4×10^{-1}	2.7×10^{-4}	7.2×10^{-6}
Medium MM	4.6	1.5	8.9×10^{-4}	1.1×10^{-1}	1.1×10^{-5}	2.9×10^{-7}
High MM	10.7	1.7	6.8×10^{-3}	1.3×10^{-1}	8.6×10^{-5}	2.3×10^{-6}
High Interactive MM	32.0	6.4	3.1×10^{-2}	4.8×10^{-1}	3.9×10^{-4}	1.0×10^{-5}
Total	109.8	32.5	2.9×10^{-1}	2.4	3.9×10^{-4}	9.9×10^{-5}

Table A1-6B: Total OBQ Up link (Mb/s/km²), Year 2010

Services	Environment					
	CBD	Urban pedestrian	Urban vehicular	Suburban	Rural	Remote
Speech	43.8	15.6	2.4×10^{-1}	1.2	3.0×10^{-3}	7.8×10^{-5}
Simple Messaging	7.0×10^{-1}	1.4×10^{-1}	2.8×10^{-3}	1.1×10^{-2}	3.5×10^{-5}	9.3×10^{-7}
Switched Data	18.0	7.2	2.2×10^{-2}	5.4×10^{-1}	2.7×10^{-4}	7.2×10^{-6}
Medium MM	27.8	8.9	5.3×10^{-3}	6.7×10^{-1}	6.7×10^{-5}	1.8×10^{-6}
High MM	166.5	26.7	1.1×10^{-1}	2.0	1.4×10^{-3}	3.6×10^{-5}
High Interactive MM	32.0	6.4	3.1×10^{-2}	4.8×10^{-1}	3.9×10^{-4}	1.0×10^{-5}
Total	289.0	64.9	4.0×10^{-1}	4.9	5.1×10^{-3}	1.3×10^{-4}

Table A1-6A: Total OBQ Down link (Mb/s/km²), Year 2010

The total OBQ of the future UMTS/IMT-2000 market for up- and down-link in different operational environment can be found by summation of the single requirements of the available services in the different geographical operating environments. In Table A1-7 the results, achieved for the year of 2010 are given. It should be noted, that that in the CBD the total required capacity is the aggregation of urban (vehicular and pedestrian) and the in building requirement as well.

Environment	2010	
	Up-link	Down-link
Forest, water and open area	9.9×10^{-5}	1.3×10^{-4}
Rural area	3.9×10^{-4}	5.1×10^{-3}
Suburban area	2.4	4.9
Urban area	32.8	65.3
Central business district	142.6	354.3

Table A1-7: Offered bit quantity (Mb/s/km²) in different operational environments

ANNEX 2

A2-1 UMTS/IMT-2000 network deployment in some countries in Central Europe

A2-1.1 Principles UMTS/IMT-2000 networks deployment

Future UMTS/IMT-2000 cellular mobile networks will be organised in a hierarchical structure. Different cell implementation will be accommodated in different frequency bands (see Table A2-1).

Cell type	Rural	Macro	Micro	Pico
Cell Radius	8 km	2 km	0.5 km	0.125 km
Application	high mobility	high mobility	low mobility/pedestrian	indoor/pedestrian
Average capacity per cell in 5 MHz	400 Kb/s	400 Kb/s	1 000 Kb/s	1 000 Kb/s
Minimum required capacity for cell operation	20 %	50 %	50 %	50 %
Frequency Channels	1	3	2	2
Number of sectors	3	3	3	1
Antenna height	30 m above local ground	3 m above roof top	5 m above local ground	indoor

Table A2-1: Expected structure of an UMTS/IMT-2000 network

The cell structures to accommodate capacity requirements of mobile customers will depend strongly on the number of available frequency channels of a certain network operator. The higher the number of available frequency channels, the lower the number of physical cells in the network. In the simulation process of the network rollout an optimistic approach has been applied; it is assumed that 8 frequency channels will be available to the network operator under consideration in the mature network deployment in the year 2010.

With respect to requirements of the network operators in terms of:

- efficient planning
- fast network rollout
- cost effectiveness

the evolution of the UMTS/IMT-2000 networks needs to be considered as well. Operators need the freedom to decide in which way the rollout of the network will evolve. On the other hand cost effectiveness requires a high grade of flexibility in the development of the backbone structures. In the starting phase Point-to-Point Fixed Service (PP FS) applications will dominate the access networks. With increasing density of the mobile network, PP FS applications in hot spots may be substituted by point-multipoint (PMP) application, shifting PP FS to suburban and rural areas.

In order to reflect this evolution process of the cellular networks and the ongoing development in the access networks of UMTS/IMT-2000 networks, the initial phase of the network rollout has to be considered in the simulations concerning the cellular networks as well:

- A reasonable approach in that respect may be the assumption of having an initial phase of network rollout which will cover those regions, where (in the mature deployment scenario) sectorised cells in the macro cell implementation are expected.
- Considering, that GSM networks will exist in parallel with UMTS/IMT-2000 at least until 2010, and 2G and 3G will offer complementary services, and the fact that in some countries only two FDD channels are initially available for the network operators (additional frequencies are expected to be available later), the second step of network deployment will provide additional capacities especially in densely populated areas.
- The third step of the network deployment scenario is the mature cellular network may be projected on the basis of the expected market of mobile services (2G and 3G) in the year 2010. This scenario will determine the full requirement of Fixed Service applications in the access- and core network of UMTS/IMT-2000. Synergic effects for operators having 2G and 3G networks need to be considered as well.

A2-1.2 Example of UMTS/IMT-2000 networks deployment in Europe

The results of all three scenarios are shown in Table A2-2, summarised in terms of coverage percentage as well as number of physical cells.

	Initial network		Mature network		
	Macro-cells	Micro-cells	Macro-cells	Micro-cells	Pico-cells
Number of cells	11100	14150	34200	34300	56600
Area coverage	18.6 %	1.5 %	57.4%	3.6 %	0.4 %

Table A2-2: Expected UMTS/IMT-2000 network deployment in central Europe

Rural cells are not considered in that respect. In order to achieve 100 % coverage, 1500-2000 additional rural cells may be necessary. Remarkable is the fact, that for an area coverage of 18 % (approximately 50%-60% of population) 11000 macro cells need to be implemented by a certain network operator. The numbers of cells given in Table A2-2 represent the physical cells which are necessary to reach the given coverage, assuming that 8 frequency channels will be available for the mature network. The number of base stations and their antenna-sectors within the network will increase according to the market share of the operator under consideration by a factor of up to 3. If the number of available frequency channels will decrease, as a consequence the number of physical cells as well as base stations and antenna sectors will increase, due the requirement of a denser network structure.

ANNEX 3

Information on the advantages of point-to-multipoint applications with regard to such features as ATM Granularity Gain, F-DCA (Fast dynamic capacity allocation), ATM multiplexing and visual impact

A3-1 ATM Granularity Gain

For PMP applications capacity is allocated on an ATM cell basis, instead of on 2 Mb/s basis (PP). In point-to-point systems, the granularity is 1*E1 - so the different capacities available are E1, 2*E1, 4*E1, 8*E1 and 16*E1. Point-to-multipoint systems enable operators to benefit from granularity gain. In PMP ATM based systems, the granularity is 1 ATM cell using the ATM interface (3G systems) or 64 Kb/s using the structured CE-interface (2G systems).

This means that if a 3G base station requires 3Mb/s transmission capacity, a point-to-point system would require a link capacity of 2*E1 (equivalent with 4Mb/s). With point-to-multipoint systems, the exact amount of capacity (3Mb/s) is delivered. So the granularity gain in this example is 1 Mb/s.

A3-2 F-DCA (Fast dynamic capacity allocation) and ATM multiplexing

The net benefit of using ATM to accommodate fluctuating capacity demands is that the network can be 'oversubscribed' in terms of number of registered users while still offering sufficient QoS, thus leading to cost savings for the operator. 3G networks require guaranteed capacity and a controlled delay.

F-DCA, in conjunction with the TDMA access scheme, is the key to allocating the capacity in a point-to-multipoint system on an ATM cell basis. The benefit of F-DCA is the ability to share capacity over the sector with full flexibility.

As above described, allocating the peak load traffic to each base station in a point-to-multipoint system, rather than the link capacity, gives a granularity gain. Overbooking the peak capacity and allocating only the average traffic load to each base station can achieve an even better utilization of the traffic resources. This traffic gain is the statistical multiplexing gain and it is achievable thanks to the dynamic capacity allocation in a point-to-multipoint system. Obviously, in order to avoid QoS degradation, the overbooking and Call Admission Control needs to be controlled via the RNC.

To give a quantitative measure of these gains a simulation has been performed that shows how a number of base stations will be aggregated in a point-to-multipoint system. The results of this simulation, shown in Figure A3-1, illustrate trunking gains in a 3G mobile backhaul system. The X-axis represents the number of connected base stations and the Y-axis is the amount of link capacity needed to connect them.

These figures assume a peak load of 4.2 Mb/s, an average load of 2 Mb/s per base station, a traffic mix of 80 per cent 'real-time' traffic (such as voice and video) and 20 per cent non-real-time data. The red line shows the traffic intensity required by multiple base stations when aggregating link capacities, the yellow line shows traffic intensity when aggregating peak load capacities, and the blue line shows the traffic intensity when aggregating average traffic loads. As can be seen in the graph, the aggregation gain increases with the number of base stations connected in the same sector. The point-to-multipoint systems will follow one of three lines, depending on its characteristics and the interfaces supported.

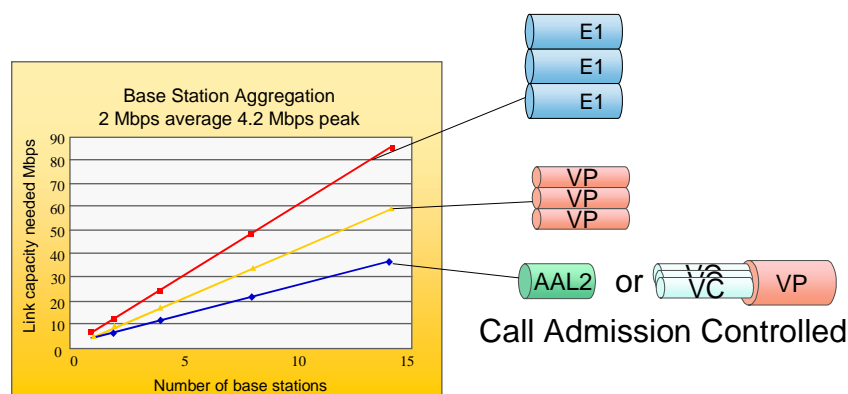

Figure A3-1: Aggregation gain.

The important conclusion is that the more air interface capacity is provided by the point-to-multipoint system, the more trunking gain is achieved.

In addition it is worth noting that the multiplexing gain capability will be even further exploited when 3G, as for a natural and foreseen evolution plan, will enable the usage of more data transport oriented ATM service categories, such as UBR; making PMP system a very future proof solution. Currently the CBR VCs handling obliges to a fixed band allocation while UBR VCs (when available), in conjunction with the PMP technology, would allow a full dynamic band allocation capability which results in the full exploiting of the statistical multiplexing gain (see figure A3-2). UBR VCs would have no PCR limit but the VP capacity, which would imply more RBSs served by the CBR VP (or more calls allowed per RBS) with no impact on GoS.

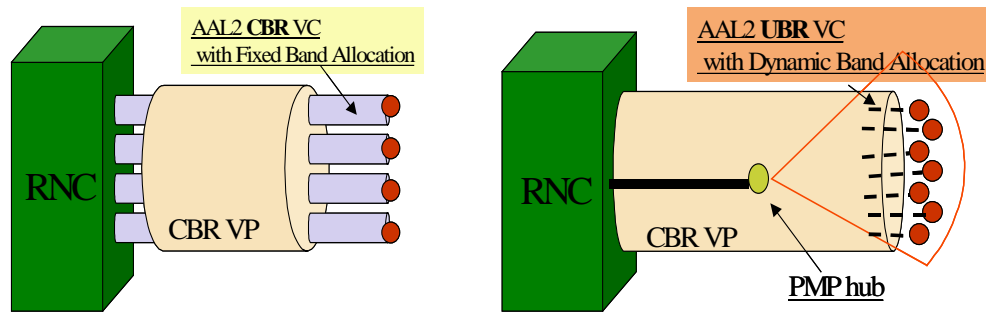

Figure A3-2: From CBR to UBR VC in UTRAN: PMP is prepared for full exploiting of the statistical multiplexing gain

A3-3 Visual impact

The point-to-multipoint central station always needs a single antenna (and a single cable between outdoor and indoor equipment) per sector irrespective of the number of Node Bs that are connected to it.

ANNEX 4

Example calculation procedure for Estimation of FS spectrum requirements for future UMTS networks

A4.1 Introduction

This Annex tries to give an example for the estimation of FS spectrum requirements for UMTS/IMT-2000 transmission networks forming interconnections between cell sites the first capacity concentration node (Node A, TCP). It describes the input data set, some assumptions and the procedure for calculation of the cell radius which was used for the design of a cell cluster. Based on these estimations in Sections 2 and 3 different layouts of transmission networks has been chosen for the evaluation of required spectrum especially in the 38 GHz band. Main focus was on urban areas and micro cells.

Considering transmission networks are defined by following parameters:

Parameter	Transmission network
Micro cell radius	330 m
Carriers per micro cell	2
Sectors per micro cell	2
Cluster size	2 x 2 km
Layout details - described in	Section 4.3
Summary of results in	Section 4.4

Layout of every transmission network example is described by:

- situation of interconnections within the cell cluster,
- proposal for frequency plan,
- main characteristics.

Technical performance of available transmission equipment was considered and calculation of interference levels were made for verification.

Finally all versions are compared with regard to bandwidth requirement and the spectrum available.

A ratio between the worst and the best case estimates were being found somewhere between a factor 2 to 3.

A4.2 Estimation of the micro cell radius

At first the size of a cell is estimated. For this purpose reference is made to Table A1-2B of the ERC-document from TG1(00)76 [2], which shows the Total Offered Bit Quantity Down Link [kbit/h/km²] for the Year 2005.

Services	CBD/Urban (in building)	Suburban (in building or on street)	Home (in building)	Urban (pedestrian)	Urban (vehicular)	Rural in- & out- door
High Interactive MM	3.78×10 ⁸	4.73×10 ⁵	5.37×10 ³	8.69×10 ⁶	2.17×10 ⁶	1.66×10 ⁴
High MM	2.76×10 ⁸	5.24×10 ⁶	2.77×10 ⁵	7.86×10 ⁷	1.35×10 ⁵	1.72×10 ³
Medium MM	2.21×10 ⁷	2.62×10 ⁵	1.38×10 ⁴	6.42×10 ⁶	1.10×10 ⁴	8.62×10 ¹
Switched Data	9.58×10 ⁷	2.99×10 ⁵	9.22×10 ³	4.76×10 ⁶	3.66×10 ⁵	5.61×10 ³
Simple Messaging	2.76×10 ⁶	5.53×10 ⁴	2.92×10 ³	8.29×10 ⁵	1.42×10 ³	1.82×10 ¹
Speech	3.52×10 ⁸	1.29×10 ⁶	5.98×10 ⁴	8.20×10 ⁷	3.56×10 ⁶	3.46×10 ⁴
<i>Total</i>	<i>1.13×10⁹</i>	<i>7.62×10⁶</i>	<i>3.68×10⁵</i>	<i>1.81×10⁸</i>	<i>6.24×10⁶</i>	<i>5.86×10⁴</i>

Table 1: Total Offered Bit Quantity Down Link [kbit/h/km²] for the Year 2005 (according to Table A1-2B of [2])

Comparison of results in the line "Total" shows that only 2 services are of interest for further estimations in respect to wireless links transport capacity:

- the category CBD (central business district) requires a total of 1.13×10^9 kbit/h/km² and
- the category Urban (pedestrian) with a total of 1.81×10^8 kbit/h/km².

All other categories are far below the totals as mentioned and therefore they are negligible for estimation of required transport capacity. Furthermore, it should be noted that OBQ in the up-link, was not considered because of lower values than in the downlink and – on the other hand – load of wireless links is normally balanced in forward and back direction.

The total OBQ in the case of CBD/Urban is 10 times higher than for the case of Urban (pedestrian) and considered to served by pico cells for the most part.

Subject	Notation	Value	Unit	Remark
Total OBQ Down Link	B_Q	1.81×10^8	kbit/h/km ²	from Ref. [2]
Total number of operators	N_O	4	---	market driven
Number of carriers per micro cell	C_M	2	---	assumed
Number of sectors per micro cell	S_M	2	---	assumed
Data rate per sector	D_S	0.9	Mb/s	assumed

Table 2: Assumptions for further calculations

Subject	Notation	Calculation	Result	Unit
Bit rate per micro cell site, net	B_S	$C_M \times S_M \times D_S$	3.6	Mb/s per cell site
Bit rate for N_O operators per unit area (rounded)	B_{AN}	$B_Q / 3600$	52	Mb/s /km ²
Bit rate per operator and per unit area	B_A	B_{AN} / N_O	13	Mb/s /km ²
Area per micro cell	A_M	B_S / B_A	0.277	km ²
Micro cell radius (rounded)	R_M	$620 \times A_M^{1/2}$	330	m

Table 3: Derivation of micro cell radius considering values of Table 2

The resulting micro cell radius matches well enough with values as found in other reports:

- according to [1]: 400 m,
- according to [2]: 500 m.

A5.3 Cluster model

General

Considerations:

- (a) only micro cells are used in the first run.
- (b) focus is set to urban area primary – if the results for the required frequency spectrum for the wireless PP links fits to frequency spectrum available then there will be no shortage for sub-urban and rural areas as well.

Fig. 1:

Dimensions of the micro cell (according to results in Table 3)

PP links are used to interconnect the cell site to a node. An additional overhead is taken into account for the determination of the transport capacity on the PP link [10], e.g. as presented in the following Table 4:

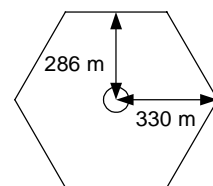

Figure 1

Subject	Notation	Calculation	Value	Unit
Bit rate per micro cell site, net	B_S	$C_M \times S_M \times d_S$	3.6	Mb/s per cell site
Overhead for signalling	O_S		1.15	---
Overhead for soft hand-over	O_H		1.40	---
ATM overhead, ranging from 20% up to 70%, depending on service	O_A		1.45	---
Accumulated overhead	O_T	$O_S \times O_H \times O_A$	2.33	---
Required transport capacity (gross bit rate per micro cell site)	B_B	$O_T \times B_S$	8.4	Mb/s per cell site

Table 4: Determination of the required transport capacity per micro cell site for the PP link:

Cluster design

In this context a cluster is formed by a number of equal sized micro cells (as shown in Fig. 1) and they are so arranged that a quadratic area is covered (Fig. 2). All respective micro cells are connected to one or two nodes by PP links.

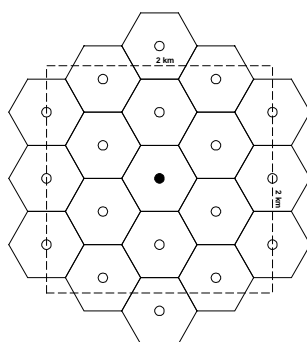

Figure 2: Layout for a cluster of 2x2 km with 1 node at centre

Cluster size	2 x 2 km	3 x 3 km	4 x 4 km
Total cluster area	4 km ²	9 km ²	16 km ²
Area per micro cell	0.277 km ²	0.277 km ²	0.277 km ²
Total no. of micro cells, approx.	14	31	56
No. of nodes per cluster	1	1	1
Required links	13	30	55
No. of micro cells per link	1	3	5
PP links per node	13	10	11

Table 5: Number of required PP links depending on cluster size (1 node)

Standard hierarchical values are used for definition of the transport capacity of aPPLink and as equipment is available on market now: 2 Mb/s , 2*2 Mb/s , 4*2 Mb/s , and so on.

Cluster size	2 x 2 km	3 x 3 km	4 x 4 km	Unit
Gross bit rate per micro cell	8.4	8.4	8.4	Mb/s
Area per micro cell	0.277	0.277	0.277	km ²
No. of micro cells per link	1	3	5	---
Gross bit rate per link	8.4	25.2	42	Mb/s
Next hierarchical transport capacity	16	34	51	Mb/s
Resulting spare capacity	7.6	8.8	9	Mb/s
Total of transport capacity, PP	13 x 16	10 x 34	11 x 51	Mb/s
Local capacity at node	8.4	8.4	8.4	Mb/s
Total capacity at node, spare capacity incl.	216	348	570	Mb/s
Total capacity at node, min. required	118	260	470	Mb/s

Table 6: Estimation of total capacity per node and per operator depending on cluster size (1 node)

Remarks:

- Cluster size of 3x3 or 4x4 km requires at least 3 hops between an outer micro cell and the node.
- Total capacity at node (min. required or based on standard hierarchy level) forming the input to the Metro (or Core) network.
- Therefore focus is set to cluster size of 2 x 2 km.

A5.4 Layout of a transmission network

General

Different structures of transmission network layout are evaluated performing interconnection of micro cells to one cluster node. Estimation of total required frequency spectrum is based on interference calculations. For simulation of several configurations the characteristics of real equipment (microwave and antenna) have been used as available on market.

Some definitions for simulation work:

Unit Bandwidth B_U

This indicator B_U was introduced to have a measure for the occupied frequency spectrum depending on required gross bit rate per link (or transport capacity). This value is based on 4-level modulation scheme (4-FSK or 4-QAM) and it represents also in special cases the channelling of the respective frequency plan. If different transport capacities are used B_U is set to the smallest value.

Transport capacity [Mb/s]	B_U [MHz]
2 x 2 or 4	3.5
4 x 2 or 8	7
2 x 8 or 16	14
2 x 16 or 34	28

Table 7: Transport capacity versus unit bandwidth (B_U)

Bandwidth of required frequency spectrum B_T

Bandwidth of total required frequency spectrum depends on layout of the interconnection network, it is defined for realisation of one cluster (and for one operator) and equals to:

$$B_T = N_C \times B_U$$

where N_C represents the number of consecutive RF channels at the node(s) including "guard" channels (if necessary to meet a predefined C/I-value). Therefore only N_C has to be evaluated for each type of transport network layout. Adjacent clusters with different layout have a small impact on cluster under consideration.

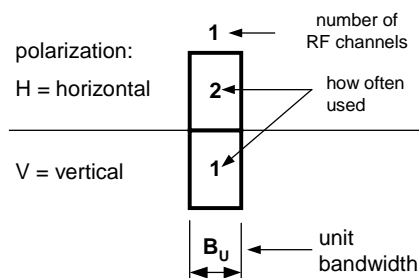

Figure 3: Frequency plan (example)

Frequency band

For assignment the frequency band is selected depending on hop length d .

Hop length d [km]	Frequency band
up to 0,7 km	58 GHz
up to 5 km	38 GHz
more than 5 km	23 GHz

Table 8: Frequency band versus hop length d (example)

Level at receiver input

In any case the level at the receiver input shall be -40 dBm within a tolerance of ± 1 dB. Therefore:

- output power of the corresponding transmitter shall be adjusted accordingly and/or
- antennas shall be chosen properly.

C/I requirements

Definitive selection of a RF channel is based on results of interference calculation, with C/I being not less than 55 dB.

Polarisation

Linear polarisation, horizontal or vertical, may be used depending on hop length (or to improve decoupling).

Layout of a transmission network

For a cluster size of 2×2 km different layouts of the transport network are evaluated.

Version 1

For this version the node is placed approximately in the centre of the cluster and each micro cell is connected by an individual PP link (Fig. 4).

Main characteristics:

- min. hop length is approx. 0.6 km,
- max. hop length is approx. 1.2 km,
- gross bit rate per micro cell (B_B) is set to the standard hierarchy level, e.g. from 8.4 to 8 Mb/s (and $B_U = 7$ MHz),
- then the total capacity at the node is 14×8 Mb/s = 112 Mb/s and no spare capacity is available.

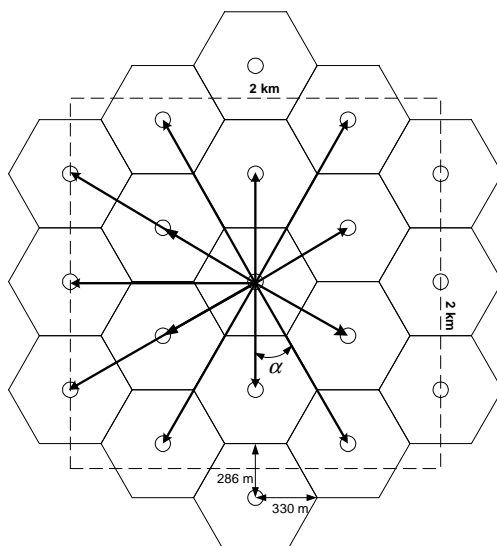

Figure 4: Layout of interconnections for Version 1

Version 1.1

For all short hops (meaning that hop length d is less than 0.7 km) frequencies are chosen from a band above 38 GHz (e.g. 58 GHz).

Frequency band	Number of links	RF channels required	hop length d [km]
38 GHz	7	$N_C \geq 2$	> 1 km
58 GHz	6	$N_C \geq 2$	$< 0,7$ km

Table 9: Main characteristics of Version 1.1

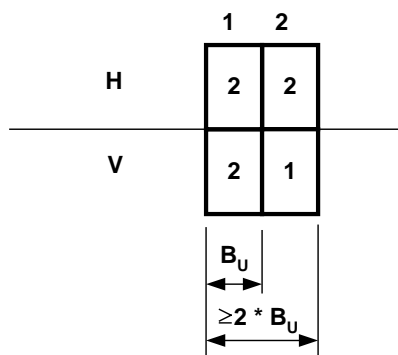

Figure 5: Frequency plan for Version 1.1

Version 1.2

All links operate in the same frequency band (e.g. 38 GHz), also the in-line connections (whereby $\alpha = 0^\circ$ between adjacent connections).

Frequency band	Number of links	RF channels required	hop length d [km]
38 GHz	13	$N_C \geq 4$	> 0.6 km

Table 10: Main characteristics of Version 1.2

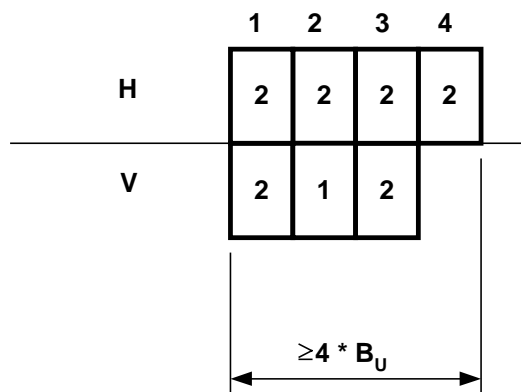

Figure 6: Frequency plan for Version 1.2

Advantages:

- same type of equipment can be used in the whole network,
- positive impact on logistics and prices,
- high availability, because only one cell is concerned in cases of interrupt,

Disadvantages:

- node has to serve many connections,
- large and expensive antenna support structure at the node,
- high potential of interference,
- not efficient use of frequencies.

Version 1.3

In this Version, all parallel connections (as described in Version 1.2) are avoided by using a neighbouring cell site for re-routing. The same frequency band is used for all connections (e.g. 38 GHz).

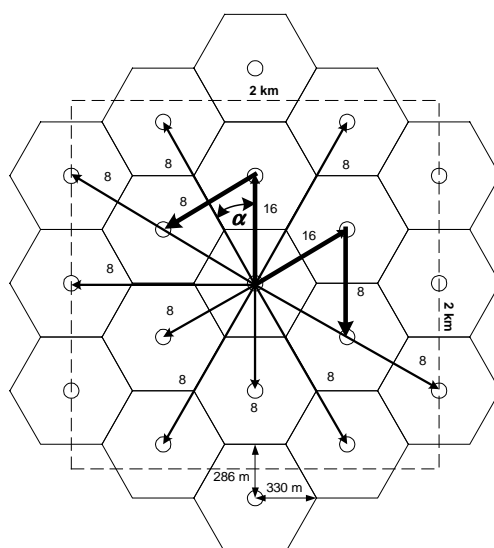
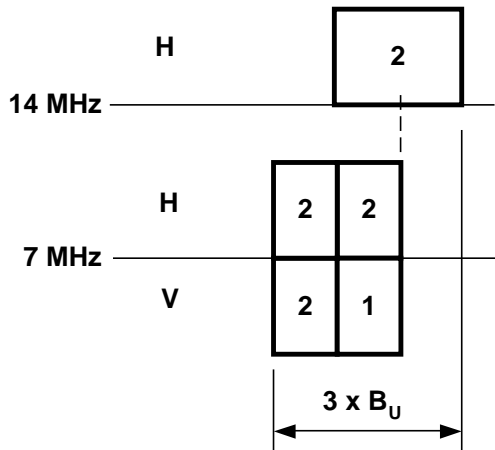

Figure 7: Layout of interconnections for Version 1.3

Frequency band	Number of links	RF channels required	hop length d [km]
38 GHz	13	$N_C \geq 3 \dots 5$, depending on discrimination (antenna; NFD)	> 0,6 km

Table 11: Main characteristics of Version 1.3

If $\alpha > 90^\circ$:



If $\alpha \sim 30^\circ$:

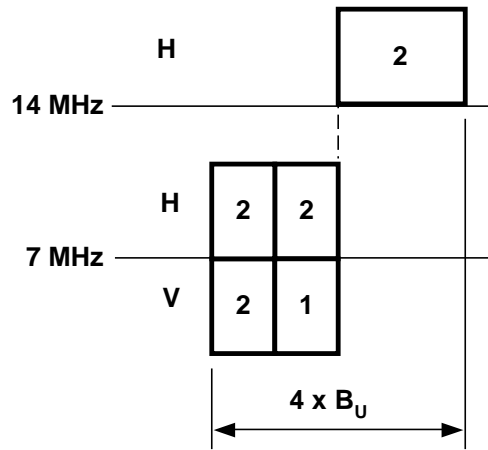

If $\alpha > 5^\circ \dots \sim 30^\circ$:

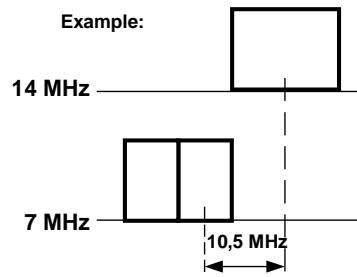
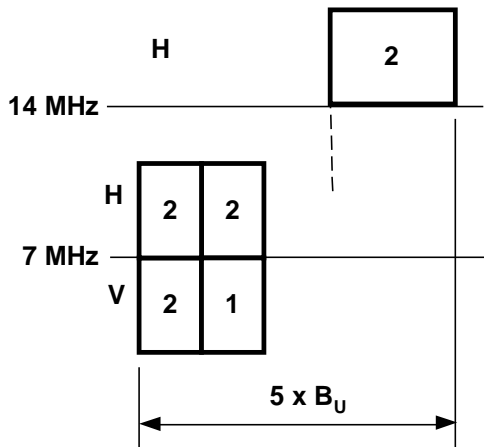

Figure 8: Frequency plan for Version 1.3

Example:

- antenna discrimination at $\alpha \sim 30^\circ$: 42 dB
- RF-equipment 14 MHz \leftrightarrow 7 MHz ca. 15 dB
- total 57 dB; condition >55 dB fulfilled

Disadvantages:

- equipment with different bandwidths,
- negative impact on economics,
- frequency allocation depends on the network structure (α),
- low spectrum efficiency.

Version 2

This case is a variation of Version 1.3, up to 3 cells are connected in series to the node. Hop length of all links is in the same order of approx. 0.6 km. Angle between neighbouring connections is mostly higher than in Version 1.x since fewer connections are led to the node. This Version was taken from Ref. [2].

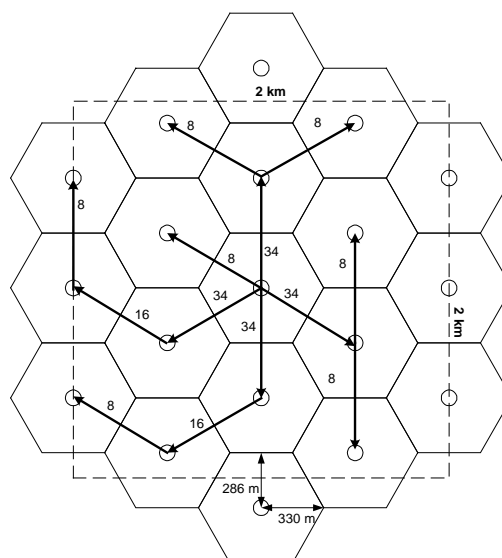

Figure 9: Layout of interconnections for Version 2

Transport capacity	Frequency band	Modulation	Channel spacing	Number links
8.4 Mb/s → 8 Mb/s	38 GHz	4 FSK, 4 QAM	7 MHz	7
16.8 Mb/s → 16 Mb/s	38 GHz	4 FSK, 4 QAM	14 MHz	2
25.2 Mb/s → 34 Mb/s	38 GHz	4 FSK, 4 QAM	28 MHz	4

Table 12: Main characteristics of Version 2

For figures in Table 12 reference is made to EN 300 197 [8].

Transport capacities were reduced from 8.4 to 8 Mb/s and from 16.8 to 16 Mb/s respectively to save licence fees; no spare capacity is available.

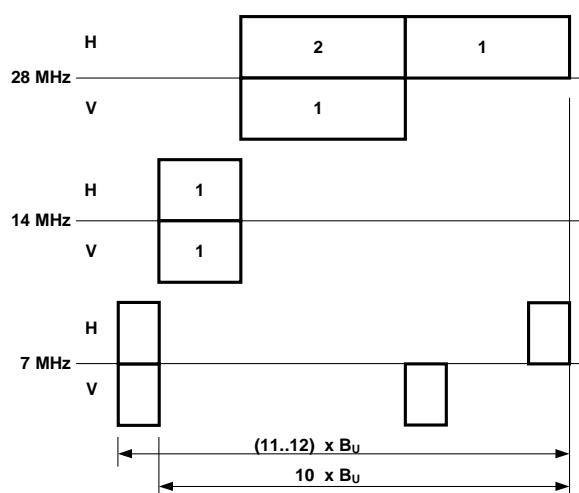

Figure 10: Frequency plan for Version 2

Version 2.1:

If all links operate in the 38 GHz band the required bandwidth is then $(11..12) \times B_U$.

Version 2.2

If all 8 Mb/s -links operate in the 58 GHz band the required bandwidth is then $10 \times B_U$.

Advantages:

- more adaptable to topographical situation

Disadvantage

- equipment with different bandwidths,
- low scale of economics, higher prices
- depending on the network structure (α) low spectrum efficiency
- in case of interrupt 3 cells are concerned.

Version 3

Also this case is a variation of Version 1. The node is shifted from the centre to one edge of the cluster. Each cell is connected by a separate link. This version is often used in Switzerland.

This configuration is characterised by:

- total enclosed angle is of about 90° ,
- mean angle between 2 adjacent links is $\alpha \geq 7^\circ$,
- min. hop length d is approx. 0.6 km,
- max. hop length d is approx. 2.1 km.

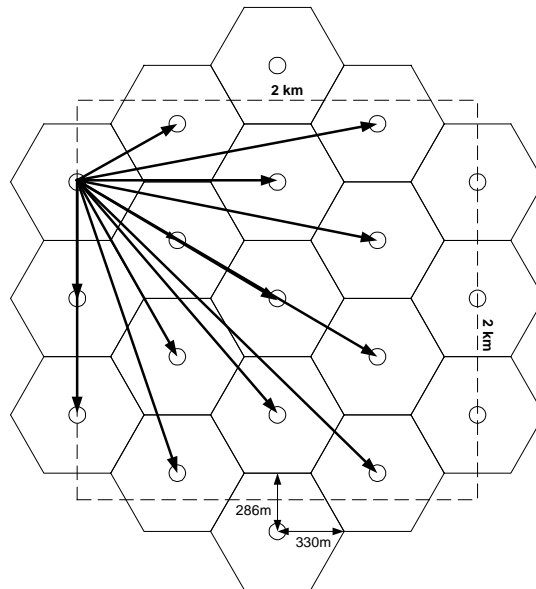

Figure 11: Layout of interconnections for Version 3

Transport capacity	Frequency band	Modulation	Channel spacing	Number of links
8.4 Mb/s → 8 Mb/s	38 GHz	4 FSK, 4 QAM	7 MHz	13

Table 13: Main characteristics of Version 3

Transport capacity was reduced from 8.4 to 8 Mb/s to save licence fees; no spare capacity is available.

Version 3.1:

- this Version contains some links in parallel,
- If all links operate in the 38 GHz band the required bandwidth is then $\geq (11..13) \times B_U$.

Version 3.2:

- this Version avoids almost links working in parallel, if all links with hop length of less than 0.7 km operate in the 58 GHz band,
- the required bandwidth in the 38 GHz band is then $\geq 6 \times B_U$.

Advantages:

- high availability, only one cell is concerned in case of interrupt,
- fits well to topographical situation where cell cluster are located in valley-like formations, like in Switzerland.

Disadvantages:

- one node has to serve many links,
- large and expensive antenna support structure at the node,
- low discrimination due to small angle between adjacent links,
- heavy showers may lead to interruptions.

Version 4

This Version is based on layout as described under Version 3, but a second node is inserted at the opposite edge of the cluster.

This configuration is characterised by:

- mean angle between two adjacent links is $\alpha \geq 10^\circ$,
- there are no links in parallel
- min. hop length d is approx. 0.6 km,
- max. hop length d is approx. 1.9 km.

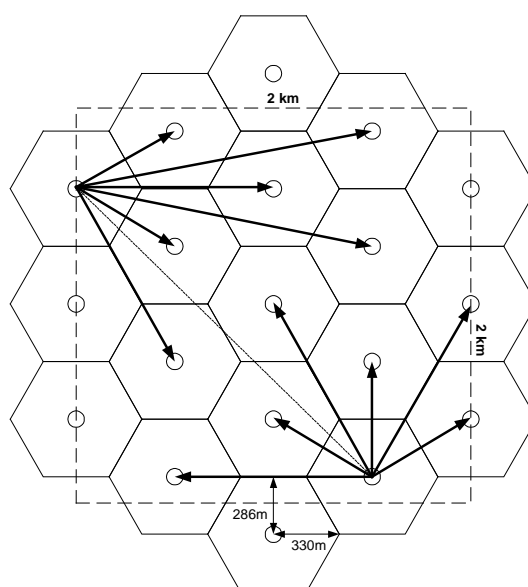

Figure 12: Layout of interconnections for Version 4

Transport capacity	Frequency band	Modulation	Channel spacing	Number of links
8,4 Mb/s → 8 Mb/s	38 GHz	4 FSK, 4 QAM	7 MHz	12

Table 14: Main characteristics of Version 4

The transport capacity was reduced from 8.4 to 8 Mb/s to save licence fees; no spare capacity is available.

The required bandwidth is $\geq 5 \times B_U$.

An additional link has to be used for interconnection of the two nodes. This link may have a capacity of $7 \times 8 \text{ Mb/s} = 56 \text{ Mb/s}$ corresponding to standard transport capacity of 51 Mb/s or 140/155 Mb/s if next higher transmission capacity is selected.

Advantages:

- same type of equipment can be used in the network, high quantity, simpler logistics, lower prices
- high availability, only one cell is concerned in case of interrupt,
- fits well with topographical situation where cell cluster are located in valley-like formations, like in Switzerland,
- higher availability because 2 nodes are used
- impact of heavy showers is lower than in Version 3.

Disadvantages:

- two nodes are required,
- separate interconnection between nodes and backbone is required.

Summary

Layout of transmission network	Version	total bandwidth required B_T	"Parallel" Links to the node	Different transport capacity	58 GHz for links of $d < 1$ km
	1.1	$\geq 2 \times B_U$	No	No	Yes
	1.2	$\geq 4 \times B_U$	Yes	No	No
	1.3	$\geq (3...5) \times B_U$	No	Yes	No
	2.1	$\geq (11...12) \times B_U$	No	Yes	No
	2.2	$\geq 10 \times B_U$	No	Yes	Yes
	3.1	$\geq (11...13) \times B_U$	Yes	No	No
	3.2	$\geq 6 \times B_U$	No	No	Yes
	4	$\geq 5 \times B_U$	No	No	No

Figure 13: Comparison for different versions of a transmission network

Figure 14 gives a graphical overview to the estimated FS spectrum requirements. For every version of the transmission network TYPE 1 the required bandwidth in the 38 GHz-band is compared with frequency spectrum available now but also related to the unit bandwidth BU.

This comparison is based on:

- for the UMTS/IMT-2000 transmission network in Switzerland it is proposed to use the 38 GHz-sub-band ranging from 37'619.75 MHz (channel no. 161) up to 37'896.75 MHz (channel no. 240),
- this frequency range available now is divided into 4 equal sized parts corresponding to 4 envisaged UMTS/IMT-2000-operators, regardless if one of the operators do not make use of allocated channels.
- for each operator a total bandwidth of 70 MHz will be made available in the 38 GHz-band (corresponding to 20 channels each 3.5 MHz)
- Additionally two channels are added to each spectrum requirement. These spare channels could be necessary to minimise interference between adjacent clusters (Fig. 15).

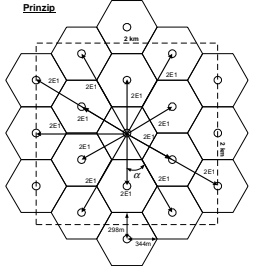
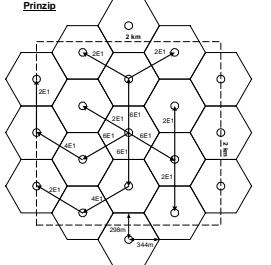
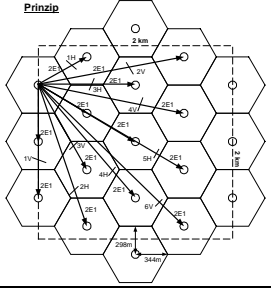
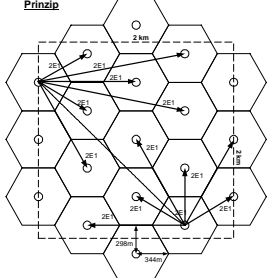
Reservation of 7 MHz should be made for the interconnection of pico cells.

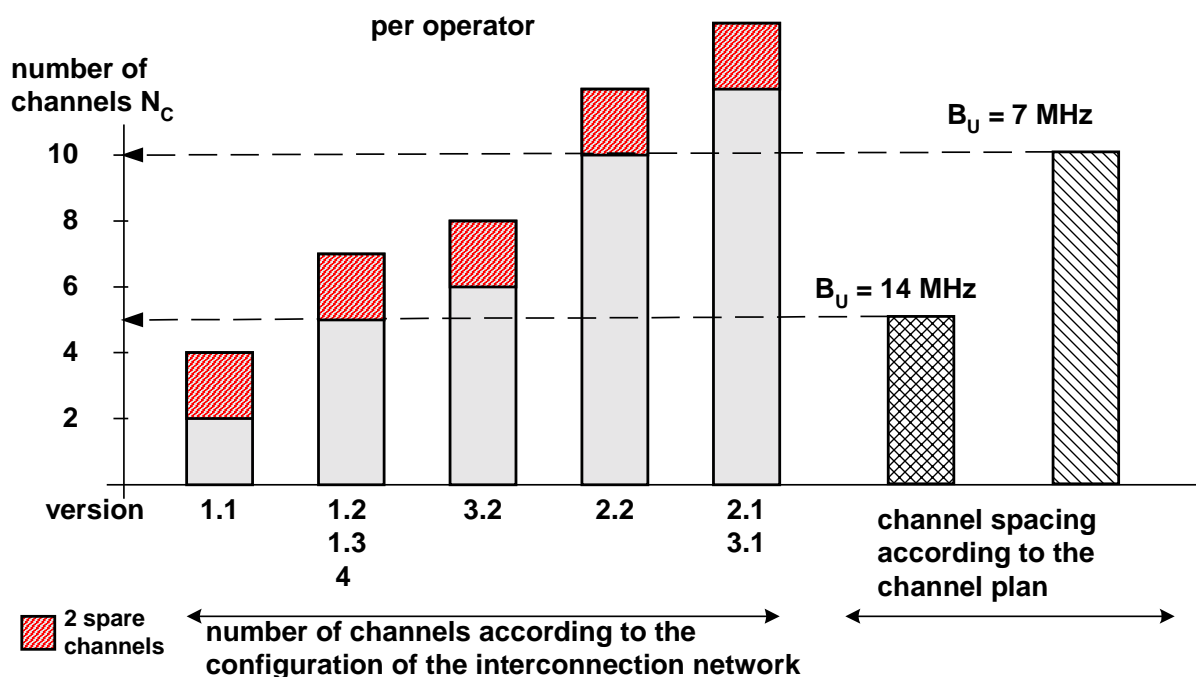

Figure 14: Requirements for total bandwidth in the frequency band 38 GHz; "CBD/urban" scenario

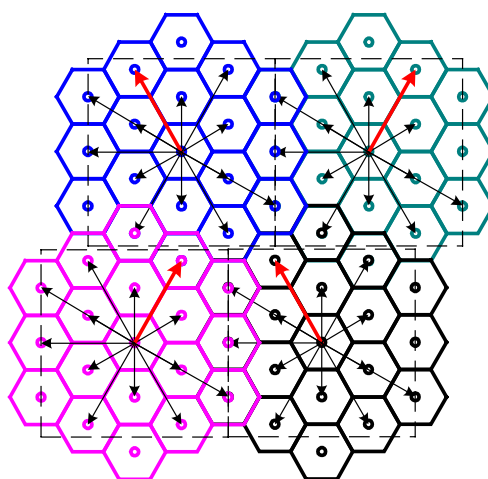

Figure 15: Possible arrangement of adjacent clusters

Glossary of notations used in this Annex

Symbol	Unit	Description
A_M	km^2	area per micro cell
B_A	Mb/s /km^2	bit rate per unit area and per operator
B_{AN}	Mb/s /km^2	bit rate per unit area for N_O operators
B_B	Mb/s	gross bit rate per cell site
B_Q	kbit/h/km^2	total offered bit quantity down link
B_S	Mb/s	bit rate per cell site
B_T	MHz	total bandwidth of required frequency spectrum
B_U	MHz	unit bandwidth
C_M	---	number of carriers per micro cell
d	km	hop length
D_S	Mb/s	data rate per sector
N_C	---	total number of required RF channels at the node
N_O	---	total number of operators
O_A	---	ATM overhead
O_H	---	overhead for soft hand-over
O_S	---	overhead for signalling
O_T	---	accumulated overhead
R_M	m	micro cell radius
S_M	---	number of sectors per micro cell

Acronyms used

CBD	Central business district
C/I	Carrier-to-Interference ratio
FS	Fixed Service
FSK	Frequency-Shift Keying
MM	Multimedia
NFD	Net-Filter Discrimination
OBQ	Offered Bit Quantity
PP	Point-to-Point
QAM	Quadrature Amplitude Modulation
RF	Radio Frequency

References used in this annex

- [1] Report from UMTS Forum Nr.5
Minimum spectrum demand per public terrestrial UMTS operator in the initial phase
- [2] ERC TG1(00)76
Methodology for simulating mature deployment of cellular networks in the mobil service
- [3] SE19(99)182rev2
Estimation of fixed service requirements for future UMTS networks
- [4] SE19(00)46
Fixed service requirements for UMTS-network szenarios
- [5] SE19(00)91
Fixed service requirements for UMTS/IMT-2000
- [6] Auswertung der Umfrage bez. RF-Anbindung von UMTS,
OFCOM internal report, 07.09.2000
- [7] Hochrechnung für Umfrage bei UMTS-Bewerbern,
OFCOM internal report, 14.09.2000
- [8] Final Draft EN 300 197 V1.3.1 (2000-08)
- [9] NFD values (Ericsson) from: Doc. SE19(99)112
- [10] Richtfunk für UMTS; Resultate der Besprechung mit E-Plus vom 15.11.00,
OFCOM internal report, 21.11.2000

ANNEX 5

Example of estimating spectrum requirements for a typical sub-network structure

This annex shows an example of estimating the necessary FS spectrum for UMTS/IMT-2000 network infrastructure. These estimates understood to be sufficient for more than 95% of typical network capacities during the first 5-7 years of development of an UMTS/IMT-2000 network. The provided estimates of necessary FS spectrum are given per operator, variations due to different situations and environments are possible.

A5-1 FS spectrum requirements below the TCP

Below the TCP the spectrum requirements can be estimated on the basis of cell clusters as described in Figure 9. In Table A6-1 the estimated FS spectrum demand for such a single cell cluster is shown.

Capacity	No. of links	Modulation states	Bandwidth per link	Required bandwidth for the cluster
8 Mb/s	16	4	7 MHz	14 MHz
16 Mb/s	4	4	14 MHz	28 MHz
34 Mb/s	4	16(4)	14(28) MHz	28(56) MHz
155 Mb/s	2	128(16)	28(56) MHz	28(56) MHz

Table A6-1: Required FS spectrum requirements for connecting Node Bs below the TCP for a single cluster

For a standalone cluster scenario the total spectrum demand will be less than the simple addition of the 4 rows in Table A6-1. Nevertheless it must be considered that the interference from neighbouring clusters will increase the spectrum requirements significantly. This situation with a set of interfering cell clusters is shown in Fig. A.6.1.

In real networks not only the next adjacent clusters will cause interference, but also the clusters located up to 30 to 50 km away will contribute to the total interference situation. This will be the reality for a typical metropolitan area.

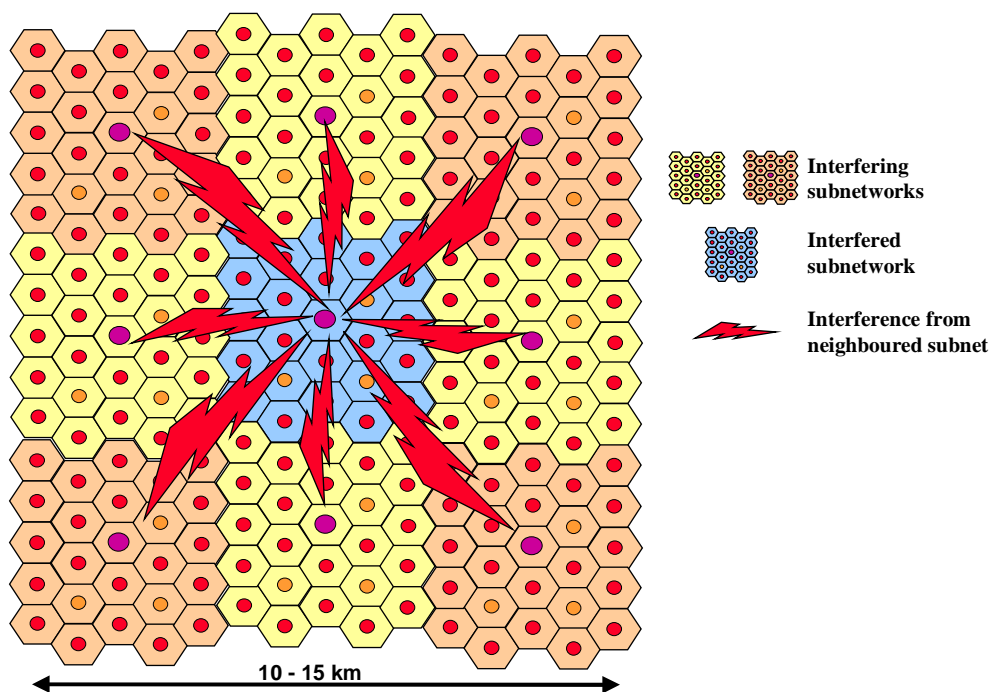

Figure A6-1. Scenario of 9 adjacent cell clusters in a dense urban area

For a complex scenario as described in figure A6-1 the requirements summarised in Table A6-2 can be recommended.

Capacity	No. of links	Modulation states	Bandwidth per link	Required bandwidth the network scenario
8 Mb/s	144	4	7 MHz	28 MHz
16 Mb/s	36	4	14 MHz	42 MHz
34 Mb/s	36	16 (4)	14(28) MHz	42(56) MHz
155 Mb/s	18	128 (16)	28(56) MHz	84(112) MHz

Table A6-2: Required FS spectrum requirements for connecting Node B below the TCP for a complex network scenario described in figure A6-1

For higher capacities (34 Mb/s and more) higher modulation schemes are recommended. The recommended bandwidths per capacity are average figures and should not be fixed to a certain capacity only. Of course it must be possible to have a flexible use of the available spectrum.

To allow a fast and flexible rollout especially in the network layer below the TCP frequency block assignments or other assignment strategies allowing a fast rollout may be a practicable measure. A block assignment strategy may be feasible only for spectrum requirements up to the medium capacity class (34 Mb/s).

Although in suburban and rural areas the common distance between the Node B will increase, the same spectrum and frequency band can be used, by changing the network from a star to a more tree oriented network topology.

Typical frequency bands for these applications at least in regions with moderate climate (i.e. precipitation up to ITU-R typical rain grade K) are 18 GHz up to 52/55 GHz.

A6-2 FS spectrum requirements between TCP and RNC

Between the TCP and RNC mostly higher capacities of at least 16 E1 for small TCP, and n times STM –1 for Node A, will become typical necessary requirements. Network specific redundancy and topological aspects, different concepts and market strength of the operators and, furthermore, a higher percentage of fibre links, all this makes recommending some generally applicable estimation of the required FS spectrum nearly impossible. However some 112 MHz spectrum per operator can be estimated, as long as fixed wireless systems will be used as the dominant transmission medium.

Since the number of links will be small compared to the network part below the TCP, link by link assignments seemed to be the more appropriate approach. Typical frequency bands are between 4 and 18 GHz, depending on the required environment (rural vs. dense urban situations) and of course climate conditions as well.

A6-3 FS spectrum requirements between RNC and MSC/SGSN

In the long term this layer of the network should be served by fibre applications. Nevertheless, in the initial phases of network deployment and even later in some cases, fixed wireless systems in this network layer might still have certain relevance.