



ECC Report **307**

Toolbox for the most appropriate synchronisation regulatory framework including coexistence of MFCN in 24.25-27.5 GHz in unsynchronised and semi-synchronised mode

approved 6 March 2020

0 EXECUTIVE SUMMARY

The purpose of this Report is to review solutions and develop regulatory options for synchronisation, in particular, to enable unsynchronised and semi-synchronised operation of MFCN in the 24.25-27.5 GHz band. In addition, the Report identifies the most appropriate synchronisation regulatory framework at national level. The regulation reference for the Report is ECC Decision (18)06 [1] which contains the baseline requirements in the form of a Block Edge Mask.

The Report extends the content in previous ECC Reports. More specifically by applying the concepts and methods from ECC Report 216 [4], ECC Report 281 [5] and ECC Report 296 [3] to MFCN in the 26 GHz band.

This Report relies on previous work for methodology and thus the background sections are compact with the intention to provide a quick overview. In order to get the full understanding the above referenced ECC Reports should be consulted.

This Report contains the simulation evaluations of MFCN in the 26 GHz band for both indoor and outdoor deployments. The assumptions used are in line with current assumptions used in e.g. ITU-R when evaluating sharing in the 26 GHz band. This Report provides a minimum separation distance for the deployments where unsynchronised operation is possible using equipment complying to baseline regulatory limits.

For smaller separation distances it is necessary to mitigate the interference. This can be done by synchronising the networks, by using semi-synchronised operation or by using an emission limit stricter than the baseline requirements (implying use of guard bands). These options can be used separately or combined depending on the desired trade-off. The Report provides a few possibilities for using these options.

For indoor deployments, unsynchronised operation is possible in adjacent channels with careful placement of the base stations using equipment complying to the baseline requirements.

In this Report, an authorisation regime where the base station locations are planned and well known has been assumed and the equipment characteristics are in line with the properties specified by ITU-R WP5D. Additional studies would be required in order to extrapolate the conclusions of this report to a different authorisation regime with unplanned deployments.

TABLE OF CONTENTS

0	Executive summary	2
1	Introduction	7
2	Background and ECC regulatory framework	8
2.1	LRTC for 5G in 24.25-27.5 GHz	8
2.2	Previous ECC studies on TDD synchronisation	8
3	Technology background	10
3.1	Synchronised, Semi-Synchronised and Unsynchroised operation	10
3.2	TDD interference scenarios	10
3.3	Frame structures	11
3.4	Benefits and drawbacks	11
4	Evaluations	12
4.1	Parameters used in Evaluations	12
4.1.1	IMT-2020 Outdoor hotspot BS parameters	12
4.1.2	IMT-2020 indoor BS parameters	13
4.1.3	IMT-2020 UE parameters	14
4.1.4	SINR operating range and mapping function	15
4.2	Evaluated Deployments	15
4.2.1	Outdoor vs. outdoor	15
4.2.2	Outdoor vs. indoor	17
4.2.3	Indoor vs. indoor	18
4.3	Evaluation 1 - OUTDOOR VS. OUTDOOR	19
4.3.1	Simulation parameters and propagation models	19
4.3.2	Simulation results	20
4.4	Evaluation 2 - OUTDOOR VS. OUTDOOR	21
4.4.1	Simulation parameters and propagation models	21
4.4.2	Simulation results	22
4.4.2.1	6 m antenna height - outdoor hotspot scenario	22
4.4.2.2	15 m antenna height - Suburban open space scenario	24
4.4.3	Summary of the simulation results in evaluation 2	26
4.4.4	Separation distance analysis	26
4.5	Evaluation 3 - OUTDOOR VS. OUTDOOR	30
4.5.1	Simulation parameters and propagation models	30
4.5.2	Simulation results	30
4.5.3	Separation distance analysis	32
4.6	Evaluation 4 - OUTDOOR VS. INDOOR	36
4.6.1	Simulation parameters and propagation models	36
4.6.2	Simulation results	36
4.7	Evaluation 5 - OUTDOOR VS. INDOOR	37
4.7.1	Simulation parameters and propagation models	37
4.7.2	Simulation results	37
4.8	Evaluation 6 - INDOOR VS. INDOOR	38
4.8.1	Simulation parameters and propagation models	38
4.8.2	Simulation results	38
4.9	Evaluation 7 - INDOOR VS. INDOOR	40
4.9.1	Simulation results	40
5	Analysis and Synthesis	41
5.1	Baseline Performance Specifications	41

5.2	Scenario comparison	41
5.2.1	Indoor vs. (outdoor and indoor) scenarios	41
5.2.2	Outdoor vs. outdoor scenarios.....	42
6	TOOLBOX: OPTIONS FOR ADMINISTRATIONS TO SUPPORT THE DESIGN OF SYNCHRONISATION FRAMEWORKS AT NATIONAL LEVEL	43
6.1	Options for agreements	43
6.2	Options for indoor deployments.....	43
6.3	Options for outdoor deployments	43
6.3.1	Geographic separation.....	43
6.3.2	Networks with separation less than above	43
6.3.2.1	Option 1: Synchronised networks.....	43
6.3.2.2	Option 2: Semi-synchronised networks	44
6.3.2.3	Option 3: Restricted baseline limit.....	44
7	Conclusions.....	45
	ANNEX 1: List of References.....	47

LIST OF ABBREVIATIONS

Abbreviation	Explanation
AAS	Active Antenna System
ACIR	Adjacent Channel Interference Ratio
ACLR	Adjacent Channel Leakage Ratio
ACS	Adjacent Channel Selectivity
AWGN	additive white Gaussian noise
BEM	Block Edge Mask
BS	Base Station
CEPT	European Conference of Postal and Telecommunications Administrations
DL	Downlink
ECC	Electronic Communications Committee
eMBB	enhanced Mobile Broadband
FDD	Frequency Division Duplex
FDD	Frequency Division Duplex
H/V	Horizontal/Vertical
HARQ	Hybrid Automatic Repeat Request
ISD	Inter-Site Distance
LOS	Line of sight
LRTC	Least Restrictive Technical Conditions
LTE	Long Term Evolution
MFCN	Mobile/Fixed Communications Networks
MS	Mobile Station
NR	New Radio
OOB	Out-Of-Block
RTT	Round Trip Time
SINR	Signal to interference plus noise ratio
SNR	Signal to noise ratio
TDD	Time Division Duplex
TRP	Total Radiated Power
TRxP	Transmit Power
UE	User Equipment
UL	Uplink
URLLC	Ultra Reliable and Low Latency Communication

Abbreviation

Explanation

WiMAX

Worldwide Interoperability for Microwave Access

1 INTRODUCTION

The 24.25-27.5 GHz band ("26 GHz band") has been harmonised for Mobile/Fixed Communications Networks (MFCN) in CEPT by ECC Decision (18)06 [1] and is recognised to be the 5G pioneer mmWave band in Europe. The 26 GHz band can provide much wider contiguous spectrum blocks than the frequency bands below 6 GHz and this makes the 26 GHz band crucial for 5G deployments in Europe and beyond.

At the time of publication of this Report, several European administrations are working on the national regulatory frameworks for the 26 GHz band and synchronisation related aspects are part of these future frameworks. The harmonised technical conditions for MFCN networks in the 26 GHz band provided in ECC Decision (18)06 and CEPT Report 068 [2] have been developed based on the assumption of individual licensing and the synchronised operation of MFCN networks in the same or neighbouring geographical areas. It is currently assumed that unsynchronised/semi-synchronised operation is possible with geographical separation (consistent with the considerations in Section 3.4 of CEPT Report 068). However unsynchronised /semi-synchronised operation of geographically overlapping or neighbouring MFCN networks is currently not addressed within the scope of the ECC deliverables referred to above. This ECC Report is therefore aimed at providing the technical material for the possible future review of these harmonised technical conditions, subject to market demand.

It is further noted that ECC Report 296 [3] is a similar ECC Report aimed at supporting administrations in setting up the synchronisation frameworks at national level for the introduction of MFCN in the 3400-3800 MHz band in a multi-operator environment leveraging on the synchronised, unsynchronised and semi-synchronised modes. ECC Report 296 further extends the contents of previous ECC Report 216 [4] and in ECC Report 281 [5] to account for 5G-NR new frame structures, the adoption of Active Antenna System (AAS) technology to MFCN base stations and also for the semi-synchronised operation which is a new mode of operation.

In this Report, the following scenarios of unsynchronised and semi-synchronised (not for all scenarios) operation in 26 GHz are analysed based on the simulations:

- Outdoor vs. outdoor;
- Outdoor vs. indoor;
- Indoor vs. indoor.

Based on the above simulations, the least restrictive technical conditions have been derived in individual simulations in terms of the minimum ACIR (Adjacent Channel Interference Ratio) and the corresponding Out-Of-Block (OOB) emission limit. Differences in the resulting OOB limits derived in individual simulations for the similar scenarios can be explained by different specific deployment assumptions (e.g. the offset angle between the aggressor and victim base stations) adopted in the different simulations.

Therefore, this ECC Report does not provide a unified recommendation for an OOB limit for the unsynchronised operation of MFCN networks in the 26 GHz band. Instead minimum distance for operating with baseline requirements is provided along with an OOB limit for operation at closer distances for unsynchronised operation.

Thus, this Report provides technical material for the future discussion on the acceptable levels of MFCN base stations' OOB emissions for unsynchronised operation which could inform the possible future revision of the existing harmonised regulatory framework for MFCN in the 26 GHz band.

In this Report, an authorisation regime where the base station locations are planned and well known has been assumed, and the equipment characteristics are in line with the properties specified by ITU-R WP5D. Additional studies would be required in order to extrapolate the conclusions of this report to a different authorisation regime with unplanned deployments.

2 BACKGROUND AND ECC REGULATORY FRAMEWORK

2.1 LRTC FOR 5G IN 24.25-27.5 GHZ

The regulatory provisions for operation of MFCN is given in ECC Decision 18(06) "Harmonised technical conditions for Mobile/Fixed Communications Networks (MFCN) in the band 24.25-27.5 GHz" [1]. This ECC Decision states the requirements for coexistence of MFCN in the band. The requirements are assuming synchronised operation.

The ECC Decision 18(06) defines two elements of the BEM in the 24.25-27.5 GHz range for the BS. The BEM elements are outlined in Table 1 below. Throughout this Report equipment complying with this BEM is loosely referred to as complying with baseline limits.

Table 1: MFCN BS BEM

BEM Element	Definition	Frequency range	Maximum Total Radiated Power (TRP)	Measurement Bandwidth
Transitional Region	These are the regions adjacent to an operator block.	0-50 MHz below or above operator block	12 dBm	50 MHz
Baseline	Applies in spectrum used for MFCN, except from the operator block in question and corresponding transitional regions.	In-band (24.25-27.5 GHz)	4 dBm	50 MHz

However, the ECC Decision 18(06) also notes that "administrations may define appropriate mitigation measures to be applied in case of unsynchronised or semi-synchronised operations, taking into account, if available, an ECC Report on a toolbox for coexistence of MFCN in unsynchronised or semi-synchronised operations. Alternatively, administrations may further develop and use an appropriate block edge mask at national level".

This Report is the one mentioned in the ECC Decision 18(06). The aim of this Report thus is to provide a basis for deciding on the most suitable synchronisation framework at a national level.

2.2 PREVIOUS ECC STUDIES ON TDD SYNCHRONISATION

The topic of synchronising TDD networks has been studied and discussed before in a number of ECC Reports and Decisions. This Report takes the approach of referencing relevant material wherever possible and will only extend into areas not previously covered.

The main ECC Reports on synchronisation approaches for TDD networks are:

- *ECC Report 216 "Practical guidance for TDD networks synchronisation" (August 2014)* [4]: This Report provides band-neutral practical guidance for synchronisation of TDD networks. The Report addresses specific BS-BS and MS-MS interference scenarios in case of unsynchronised operation and provides background about synchronised operation, definitions, technical aspects for clock and phase/time, cross-technology frame alignment between WiMAX/LTE-TDD, and options for administrations for designing a general framework at the national level for synchronised operation in a multi-operator context;
- *ECC Report 281 "Analysis of the suitability of the regulatory technical conditions for 5G MFCN operation in the 3400-3800 MHz band" (July 2018)* [5] and *ECC Decision (11)06 "Harmonised frequency arrangements and least restrictive technical conditions (LRTC) for mobile/fixed communications networks (MFCN) operating in the band 3400-3800 MHz" (October 2018)* [6]: These define the Least Restrictive Technical Conditions (LRTCs) applicable to 5G MFCN using non-AAS and AAS base station systems in the 3400-3800 MHz band. Such LRTCs extend the LRTCs defined in ECC Report 203 [7] (which was

based on IMT-Advanced/4G). The LRTCs include the baseline out of block power limit and the transitional regions power limits to be used in case of synchronised operation as well as the restricted baseline out of block power limit to be used in case of unsynchronised and semi-synchronised operation.

- *ECC Report 296 “National synchronisation regulatory framework options in 3400-3800 MHz: a toolbox for coexistence of MFCNs in synchronised, unsynchronised and semi-synchronised operation in 3400-3800 MHz” (January 2019) [3]:* This Report provides guidance on the most appropriate synchronisation framework for MFCN operating in 3400-3800 MHz. It discusses synchronised, semi-synchronised and unsynchronised operation including definitions, benefits and challenges. In addition, it provides quantitative analysis for AAS systems coexisting in this band. Finally, this Report provides recommendations for administrations that intend to implement a regulatory framework.
- *ECC Recommendation (15)01 “Cross-border coordination for mobile/fixed communications networks (MFCN) in the frequency bands: 694-790 MHz, 1452-1492 MHz, 3400-3600 MHz and 3600-3800 MHz” (February 2016) [8].* This ECC Recommendation addresses synchronisation and coordination of TDD MFCN networks across national borders.

3 TECHNOLOGY BACKGROUND

In this section, the generic technology topics related to TDD are discussed. The intention is to give a brief overview. These topics are similar for many TDD bands and thus references to other relevant reports are used whenever possible.

3.1 SYNCHRONISED, SEMI-SYNCHRONISED AND UNSYNCHRONISED OPERATION

ECC Report 281 [5] contains the definition of synchronised, semi-synchronised and unsynchronised operation:

Synchronised operation:

The synchronised operation in the context of this Report means operation of TDD in several different networks, where no simultaneous UL and DL transmissions occur, i.e. at any given moment in time either all networks transmit in DL or all networks transmit in UL. This requires the alignment of all DL and UL transmissions for all TDD networks involved as well as synchronising the beginning of the frame across all networks.

Unsynchronised operation:

The unsynchronised operation in the context of this Report means operation of TDD in several different networks, where at any given moment in time at least one network transmits in DL while at least one network transmits in UL. This might happen if the TDD networks either do not align all DL and UL transmissions or do not synchronise at the beginning of the frame.

Semi-synchronised operation:

The semi-synchronised operation corresponds to the case where part of the frame is consistent with synchronised operation as described above, while the remaining portion of the frame is consistent with unsynchronised operation as described above. In particular, semi-synchronised operation requires the adoption of a default frame structure (for which UL/DL directions are defined across the whole frame) and at the same time the definition of the part of the frame where each operator is allowed to reverse the default transmission direction (flexible part). As a consequence, for semi-synchronised operations two possible modifications compared to the default frame structure are possible:

- DL to UL modifications: in case an operator selects the UL direction in the flexible part while the default frame structure adopts the DL direction;
- UL to DL modifications: in case an operator selects the DL direction in the flexible part while the default frame structure adopts UL direction.

In ECC Report 296 [3], the differences and commonalities between these modes of operation are further elaborated. In addition, this Report discusses the implications on clock and frame structure alignment as well as the out of block power limits.

3.2 TDD INTERFERENCE SCENARIOS

Different interference scenarios may occur when two TDD networks are deployed in blocks within the same band (including the co-channel case and the adjacent channel case). Cross link interference will occur when simultaneous transmissions in uplink (UL) and downlink (DL) directions take place in different TDD networks (i.e. one BS (or MS) belonging to one network transmits while another BS (or MS) belonging to the other network receives (this will be referred to as "simultaneous UL/DL transmissions" throughout this Report).

Figure 1 (from ECC Report 296 [3]) illustrates the interference scenarios in case of simultaneous UL/DL transmissions: the green arrows represent the desired links, while the potential interference is represented by the yellow arrows. BS-MS interference happens in all cases (FDD and TDD, whether synchronised or not) and is handled as part of the standards. MS-MS and BS-BS interference in unsynchronised and semi-synchronised TDD networks is within the scope of this Report.

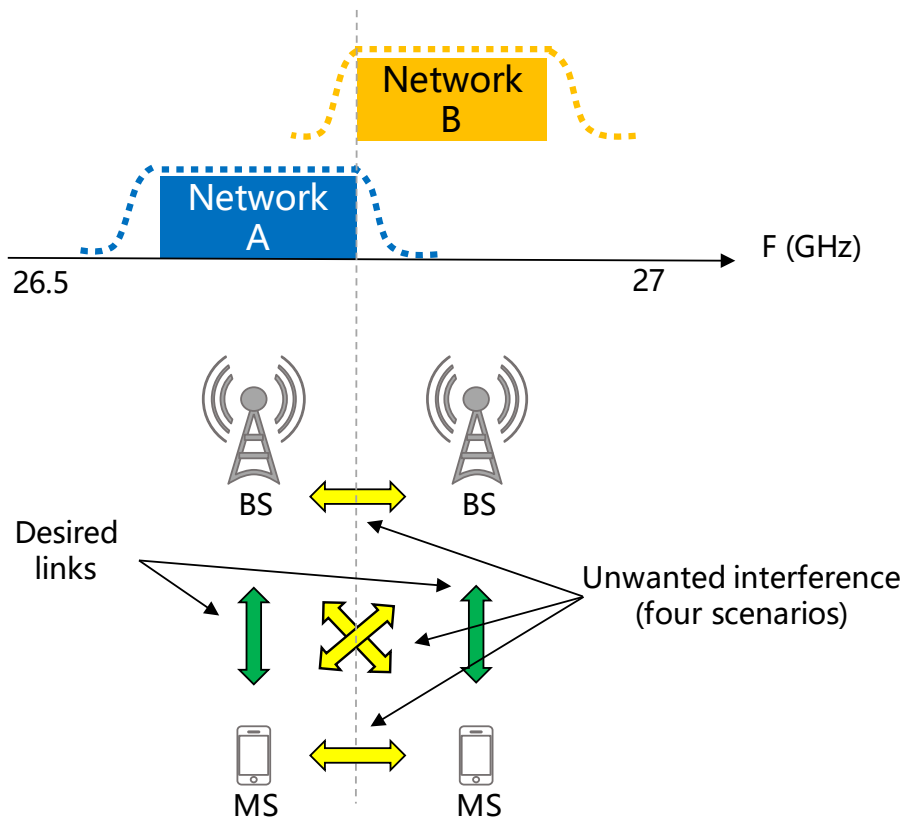

Figure 1: Interference scenarios in case of simultaneous UL/DL transmissions in MFCN TDD networks

3.3 FRAME STRUCTURES

The frame structure selection has an impact on several aspects of network performance, including:

- DL/UL traffic ratio;
- Spectrum utilisation efficiency;
- RTT (Round Trip Time) latency;
- Coverage (DL sync. channel coverage and UL coverage).

These topics are extensively discussed in ECC Report 296 [3], although this Report discusses the 3400-3800 MHz frequency range many conclusions also hold for 26 GHz e.g. the frame structure lengths will have the same impact on latency. One of the key differences between the 3400-3800 MHz frequency range and the 26 GHz band is that there are no LTE deployments in the 26 GHz band. Thus, for the 26 GHz band the considerations relating to alignment of NR and LTE frame structures do not apply.

3.4 BENEFITS AND DRAWBACKS

The benefits and drawbacks of synchronised, semi-synchronised and unsynchronised operation are discussed in ECC Report 296. The areas discussed mainly revolve around the implications on clock and frame structure alignment as well as the out of block power limits.

The same benefits and drawbacks qualitatively apply in this band as well, but the exact trade-off has to take into account the change in propagation conditions for this frequency range.

4 EVALUATIONS

All evaluations assume that the networks are fully unsynchronised with the exceptions of the evaluations done for semi-synchronised networks.

4.1 PARAMETERS USED IN EVALUATIONS

4.1.1 IMT-2020 Outdoor hotspot BS parameters

Table 2: Outdoor BS parameters

Parameter	Value
General	
Duplex method	TDD
Band of operation	26 GHz
Channel Bandwidth	200 MHz
Antenna height (radiation centre)	6 m or 15 m (above ground level)
Sectorisation	3 sectors
Downtilt	10 or 15 degrees
Antenna deployment	Below roof top/At the edge of the roof
Network loading factor	100% (full buffer traffic)
Antenna Pointing	Directly toward served UE
Antenna Characteristics	
Antenna pattern	Refer to Recommendation ITU-R M.2101 [13]
Element gain	5 dBi
Horizontal/vertical 3 dB beamwidth of single element (degree)	65° for both Horizontal/vertical
Horizontal/vertical front-to-back ratio (A_m and S_{LAV})	30 dB for both Horizontal/vertical
Antenna polarisation	Linear $\pm 45^\circ$
Antenna array configuration (Row \times Column)	8x8 elements
Horizontal/Vertical radiating element spacing	0.5 of wavelength for both Horizontal/vertical
Array Ohmic loss (dB)	3
Total Radiated Power (TRP)	25 dBm/200 MHz
Antenna Normalisation	Applied
Transmitter Characteristics	
Power dynamic range (dB)	0 dB conducted BS output power
Spurious emissions	-13 dBm/MHz Total Radiated Power
Conducted power (before Ohmic loss) per antenna element (dBm/200 MHz)	10
Receiver Characteristics	
Noise figure	10 dB

Parameter	Value
Sensitivity	–
ACS	23.5 dB
SINR operating range	The SINR mapping function is given in section 4.1.4

4.1.2 IMT-2020 indoor BS parameters

Table 3: Indoor BS parameters

Parameter	Value
General	
Duplex method	TDD
Band of operation	26 GHz
Channel Bandwidth	200 MHz
Antenna height (radiation centre)	3 m above floor level
Sectorisation	Single sector
Downtilt	90 degrees (ceiling mount)
Antenna deployment	N/A
Network loading factor	100% (full buffer traffic)
Antenna Pointing	Directly toward served UE
Antenna Characteristics	
Antenna pattern	Refer to Recommendation ITU-R M.2101 [13]
Element gain (dBi)	5
Horizontal/vertical 3 dB beamwidth of single element (degree)	90° for both Horizontal/vertical
Horizontal/vertical front-to-back ratio (dB)	25 for both Horizontal/vertical /
Antenna polarisation	Linear $\pm 45^\circ$
Antenna array configuration (Row \times Column)	8x8 elements
Horizontal/Vertical radiating element spacing	0.5 of wavelength for both Horizontal/vertical
Array Ohmic loss (dB)	3
Total Radiated Power (TRP)	23 dBm/200 MHz
Antenna Normalisation	Applied
Transmitter Characteristics	
Power dynamic range (dB)	0 dB conducted BS output power
Spurious emissions	–13 dBm/MHz Total Radiated Power
Conducted power (before Ohmic loss) per antenna element (dBm/200 MHz)	5
Receiver Characteristics	
Noise figure	10 dB
Sensitivity	–

Parameter	Value
ACS	23.5 dB
SINR operating range	The SINR mapping function is given in section 4.1.4

4.1.3 IMT-2020 UE parameters

Table 4: UE parameters

Parameter	Value
General	
UE Height	1.5 m above ground
Antenna parameters	
Body loss resulting from proximity effects	4 dB
Antenna pattern	Refer to Recommendation ITU-R M.2101 [13]
Element gain	5 dBi
Horizontal/vertical 3 dB beamwidth of single element (degree)	90° for both Horizontal/vertical
Horizontal/vertical front-to-back ratio (dB)	25 for both Horizontal/vertical
Antenna polarisation	Linear ±45°
Antenna array configuration (Row × Column)	4x4 elements
Horizontal/Vertical radiating element spacing	0.5 of wavelength for both Horizontal/vertical
Array Ohmic loss (dB)	3
Antenna normalisation	Applied
Transmitter Characteristics	
Power dynamic range (dB)	63 dB
ACLR (Adjacent Channel Leakage Ratio)	17 dB
Spurious emissions	-13 dBm/MHz Total Radiated Power
Conducted power (before Ohmic loss) per antenna element (dBm/200 MHz)	10
Power control model	Refer to Recommendation ITU-R M.2101 [13]
Maximum user terminal output power, PCMAX	22 dBm
Transmit power (dBm) target value per 180 kHz, P_{0_PUSCH}	-95
Path loss compensation factor, α	1
Receiver Characteristics	
Noise figure	10 dB
Sensitivity	–
ACS	22.5 dB
SINR operating range	The SINR mapping function is given in section 4.1.4

4.1.4 SINR operating range and mapping function

The following equations approximate the throughput over a channel with a given SINR, when using link adaptation:

$$\text{Throughput (SINR), bps/Hz} = \begin{cases} 0 & \text{for } SINR < SINR_{MIN} \\ \alpha \cdot S(SINR) & \text{for } SINR_{MIN} \leq SINR < SINR_{MAX} \\ \alpha \cdot S(SINR_{MAX}) & \text{for } SINR \geq SINR_{MAX} \end{cases}$$

Where:

- $S(SINR)$ Shannon bound, $S(SINR) = \log_2(1+SINR)$ (in bps/Hz);
- α Attenuation factor, representing implementation losses;
- $SINR_{MIN}$ Minimum SINR of the code set, dB;
- $SINR_{MAX}$ Maximum SINR of the code set, dB.

The parameters α , $SINR_{MIN}$ and $SINR_{MAX}$ can be chosen to represent different modem implementations and link conditions. The parameters proposed in Table 5 represent a baseline case, which assumes:

- 1:1 antenna configurations;
- AWGN channel model;
- Link Adaptation (see table 5 for details of the highest and lowest rate codes);
- No HARQ.

Table 5: Parameters describing baseline Link Level performance for 5G NR

Parameter	DL	UL	Notes
α	0.6	0.4	Represents implementation losses
$SINR_{MIN}$, dB	-10	-10	Based on QPSK, 1/8 rate (DL) & 1/5 rate (UL)
$SINR_{MAX}$, dB	30	22	Based on 256QAM 0.93(DL) & 64QAM 0.93 (UL)

4.2 EVALUATED DEPLOYMENTS

4.2.1 Outdoor vs. outdoor

In this deployment, there are two networks with uncoordinated locations of base stations consisting of three-sector sites in a hexagonal layout. The networks are shifted so that the minimum distance between two BS is what is defined in Table 6. The direction of the antennas can be the same which results in a 30 degree offset between the victim and aggressor independent of the network shift. This is illustrated in Figure 2. The BS in the victim network can also be rotated 30 degrees so that the offset between the victim and aggressor is 0 degrees. This is illustrated in Figure 3.

Table 6: Outdoor vs. outdoor deployment

Parameter	Value
Inter-site distance	200 m
Minimum distance between nodes (network shift)	One of: 30 m, 70 m and 115 m
Offset angle between aggressor and victim	0 or 30 degrees
BS heights	Two cases: 6 m height in both networks and 15 m height in both networks
UE distribution	Random uniform distribution over the cells

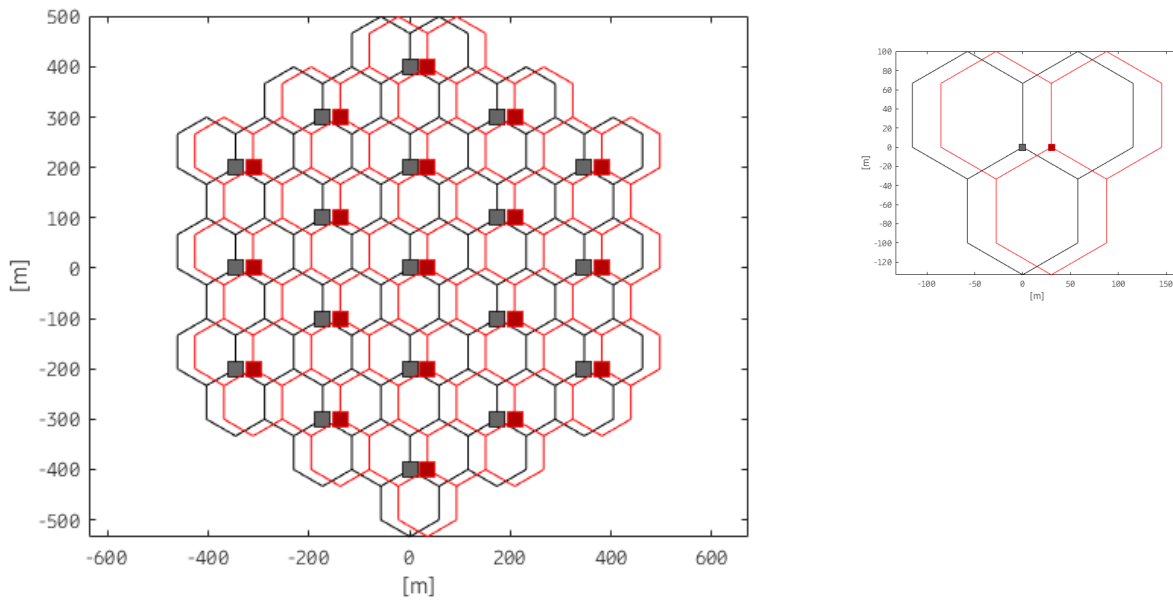

Figure 2: Outdoor vs. outdoor deployment with 30 m distance and 30 degrees offset

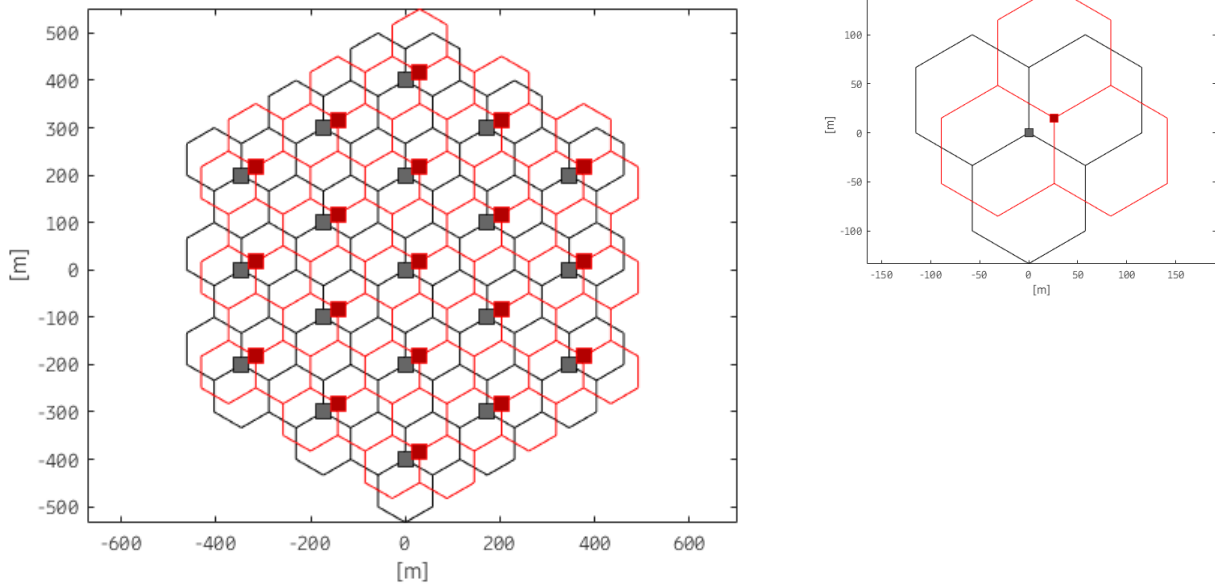

Figure 3: Outdoor vs. outdoor deployment with 30 m distance and 0 degrees offset

Table 7: Outdoor vs. outdoor propagation modelling

Link	Propagation model
BS-UE	Report ITU-R M.2412-0 [11]
BS-BS	For 6 m BS antenna height: Report ITU-R M.2412-0 For 15 m BS antenna height: Report ITU-R M.2412-0 [11] or free space
UE-UE	N/A

4.2.2 Outdoor vs. indoor

The indoor system consists of a single building with 3 access points. One building is placed in a hexagonal grid of outdoor BS with either the short or long wall facing the BS. The system layout is illustrated in Figure 4.

Table 8: Outdoor vs. indoor deployment

Parameter	Value
Indoor system deployment	Indoor office: Floor dimensions: 120 m × 50 m × 3 m Number of cells: 3 ISD = 40 m

Parameter	Value
Minimum distance between outdoor BS and building wall (network shift)	30 m
Building orientation	Outdoor BS in the middle of short wall or long wall (2 cases)
BS heights	Outdoor BS: 6 m Indoor BS: 3 m
UE distribution	Indoor office: Random uniform distribution in the building. Outdoor: Random uniform distribution over the cells except the area occupied by the building.

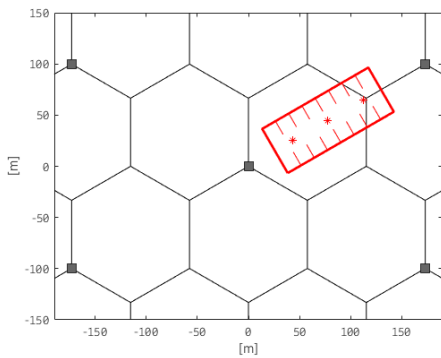

Case 1

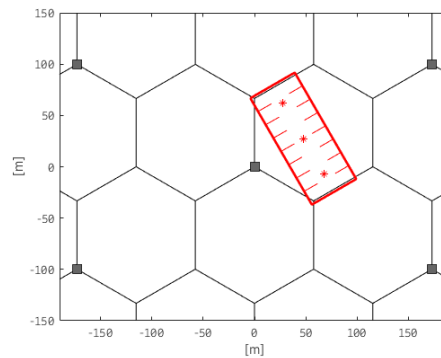

Case 2

Figure 4: System layout for Case 1 (short wall facing the BS) and Case 2 (long wall facing the BS)

Table 9: Outdoor vs. indoor propagation modelling

Link	Propagation model
BS-UE	Report ITU-R M.2412-0 [11], For building entry loss Recommendation ITU-R P.2109-0 [12]
BS-BS	Report ITU-R M.2412-0, For building entry loss Recommendation ITU-R P.2109-0
UE-UE	N/A

4.2.3 Indoor vs. indoor

To evaluate two indoor systems a 100x140 m building is used. Inside the building, 6 BS are deployed for each system. The deployment is illustrated in Figure 5 below.

Table 10: Indoor vs. indoor parameters

Parameter	Value
Floor dimension	100 x 140 x 3 m
Number of cells	6
ISD	40 m
BS height	3 m (ceiling mounted)
UE distribution	Random uniform distribution in the building

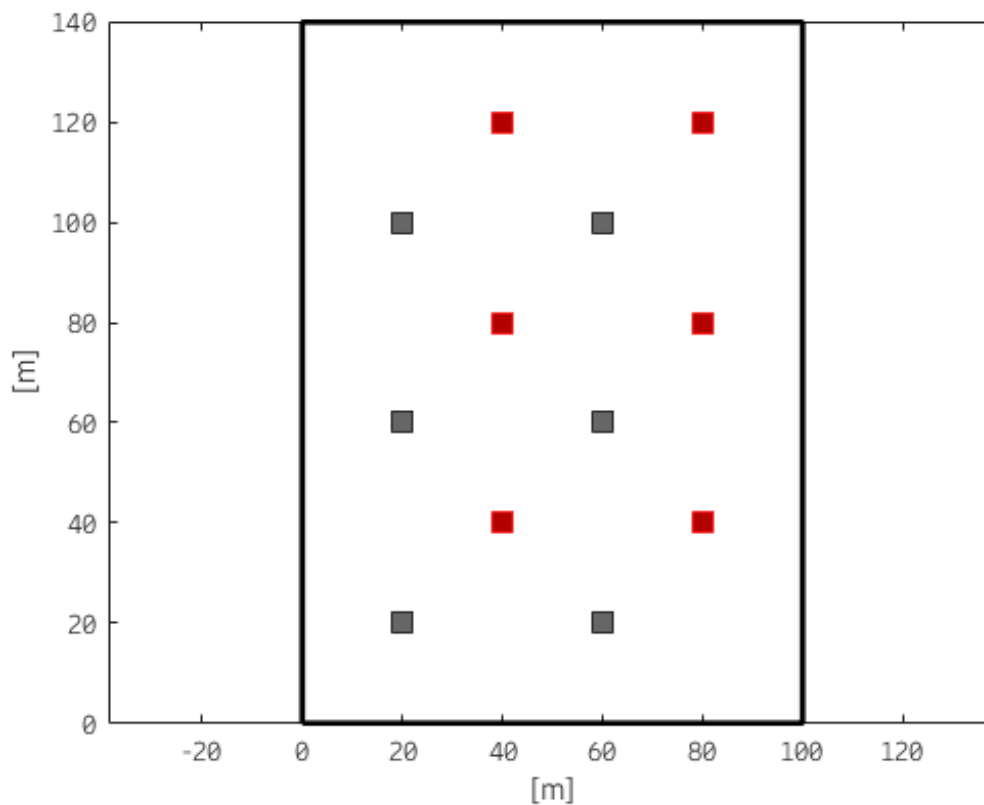
**Figure 5: System layout for indoor vs. indoor case****Table 11: Indoor vs. indoor propagation modelling**

Link	Propagation model
BS-UE	3GPP indoor
BS-BS	3GPP indoor or free-space

4.3 EVALUATION 1 - OUTDOOR VS. OUTDOOR

4.3.1 Simulation parameters and propagation models

The parameters used are according to the ones shown in Section 4.1 with the following exceptions and the following selected options:

Table 12: IMT-2020 parameters used in the simulations

Parameter	Value
BS Antenna height (radiation centre)	6 m
Downtilt	10 degrees
Minimum distance between nodes (network shift)	30, 50, 70 and 115 m
Offset angle between aggressor and victim	30 degrees

4.3.2 Simulation results

The uplink throughput is evaluated in an area with two macro networks deployed. In the propagation model there is a random component that models variation on building loss and other variations in the physical layout of the environment. Since the propagation between base stations is not likely to change simulations have been done where BS-BS propagation is determined once and kept constant for the entire simulation. During the simulation other things are changed though, such as user location. In Figure 6, the result of 20 different simulations is shown with a 30 m BS-BS separation distance. The results show that an ACIR in the range between 24 and 33 dB is required to achieve less than 5% throughput loss in this scenario. In average an ACIR of 29 dB is required.

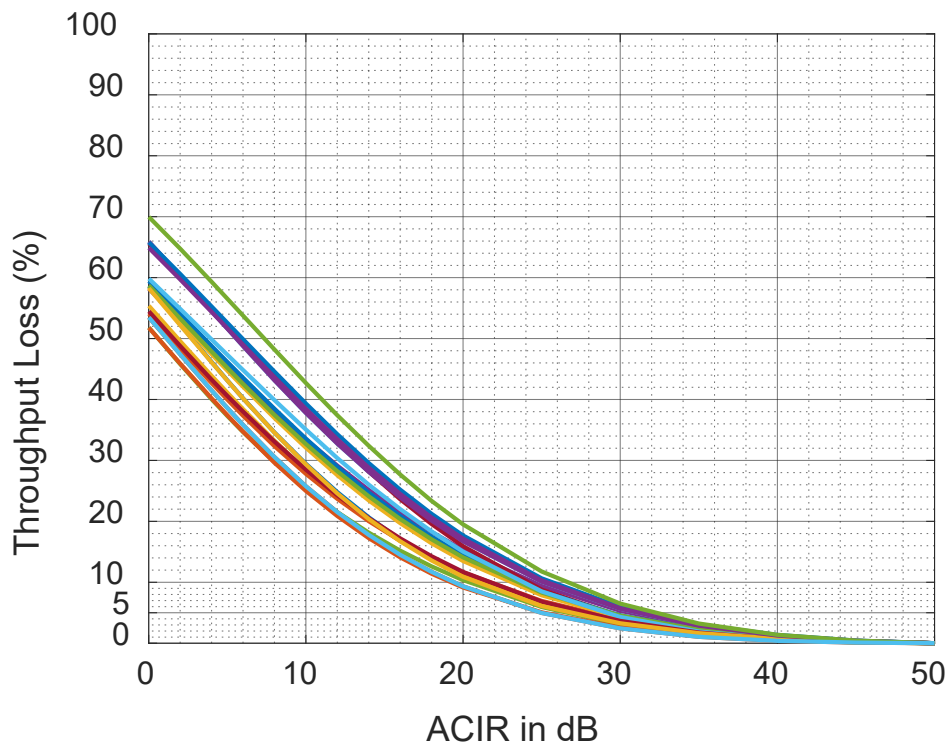

Figure 6: Uplink throughput loss averaged over the outdoor hotspot BS serving different users for different realisations of the channel model for 6 m BS height with 30 m BS-BS separation

In Figure 7, the values for 20 simulations are averaged for each separation distance.

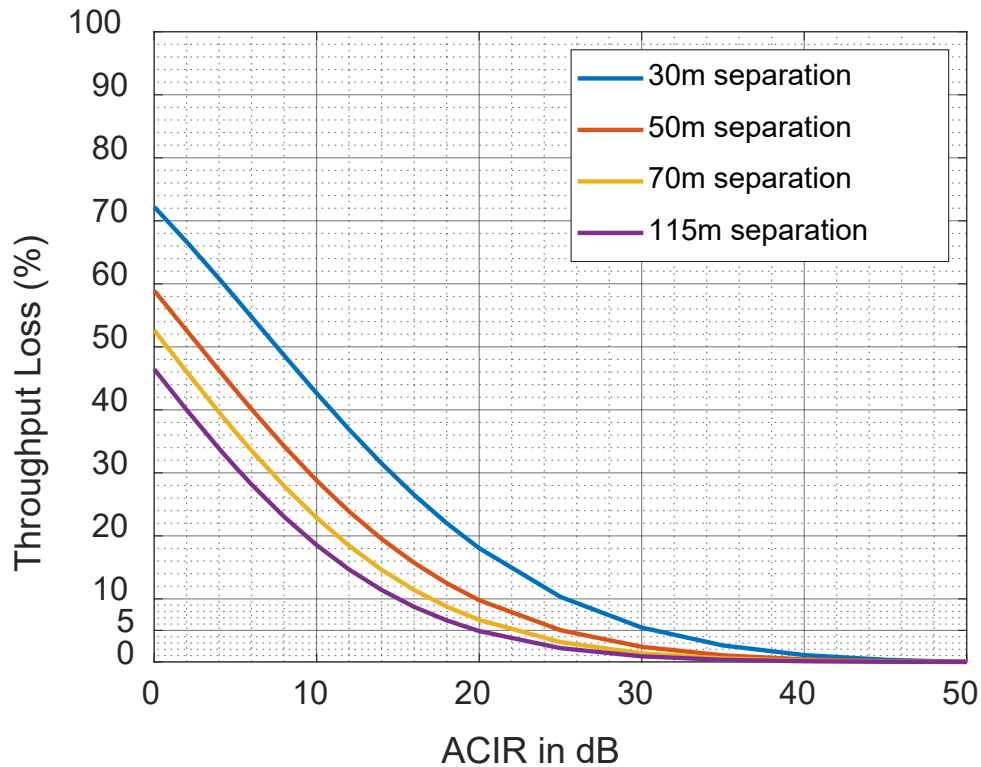

Figure 7: Uplink throughput loss averaged for each separation distance over the outdoor hotspot BS serving different users for different realisations of the channel model for 6 m BS height

4.4 EVALUATION 2 - OUTDOOR VS. OUTDOOR

The deployment used is the deployment in section outdoor vs. outdoor deployment. The base station offset is 0 degrees.

4.4.1 Simulation parameters and propagation models

The parameters used are according to the ones shown in Section 4.1 with the following exceptions and the following selected options:

Table 13: IMT-2020 parameters used in the simulations

Parameter	For 6 m antenna height (urban/suburban hotspot)	For 15 m antenna height (suburban open space)
BS-BS propagation model	Report ITU-R M.2412-0 [11]	Recommendation ITU-R P.525 [14] (free-space path loss)
Antenna downtilt	10°	15°
Interferer-victim sites offset	30 m	30 m, 70 m
Antenna boresites offset	0°	0°
Beamforming, UEs distribution	Beamforming towards UEs (closest beam out of the beamset serves individual UEs) UEs uniformly distributed in each hexagonal cell	Beamforming towards UEs (closest beam out of the beamset serves individual UEs) UEs are uniformly distributed in each hexagonal cell
Beam set at TRxP (Constraints for the range of individual analogue beams per TRxP)	For direction of TRxP analogue beam steering (in local co-ordinates): Azimuth angle ϕ_{ai_i} : (-56.25°, -33.75°, -11.25°, 11.25°, 33.75°, 56.25°) Zenith angle theta (incl. mechanical downtilt): 6x3 beamset : j = (84°, 96°, 129°) 6x4 beamset: j = (84°, 96°, 112°, 129°) NOTE: (azimuth, zenith)=(0, 90) is the direction perpendicular to the array plane.	

4.4.2 Simulation results

4.4.2.1 6 m antenna height - outdoor hotspot scenario

Figure 8 shows the estimated degradation of the mean uplink throughput of the victim MFCN network due to base station to base station interference for the urban/suburban hotspot scenario, presented as a function of ACIR.

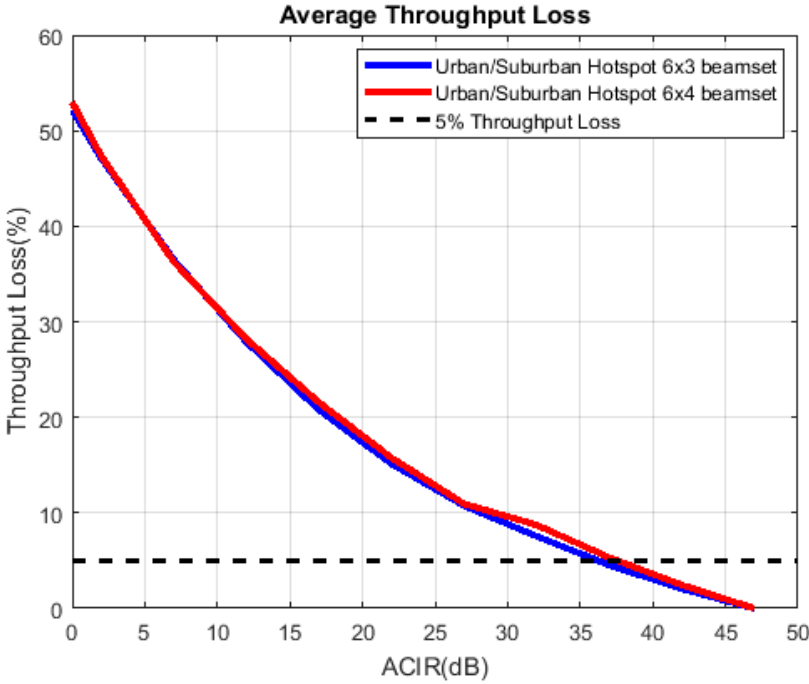

Figure 8: Impact of base station to base station interference on mean uplink throughput, outdoor hotspot with 6 m antenna height (ACIR) and 30 m offset between interferer and victim BS

Figure 9 shows the estimated degradation of the mean uplink throughput of the victim MFCN network due to base station to base station interference for the urban/suburban hotspot, presented as a function of the absolute OOB emission limit in dBm/MHz.

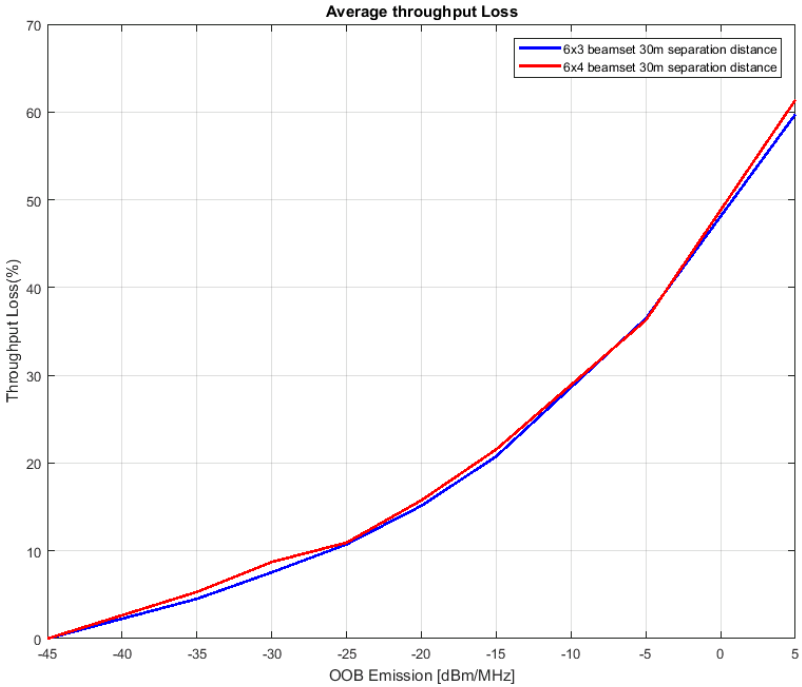

Figure 9: Impact of base station to base station interference on mean uplink throughput, outdoor hotspot with 6 m antenna height (OOB emission limit) and 30 m offset between interferer and victim BS

4.4.2.2 15 m antenna height - Suburban open space scenario

Figure 10 and Figure 11 (for 30 m and 70 m offsets between the interferer base station and the victim base station respectively) show the estimated degradation of the mean uplink throughput of the victim MFCN network due to base station to base station interference for the suburban open space scenario, presented as a function of ACIR.

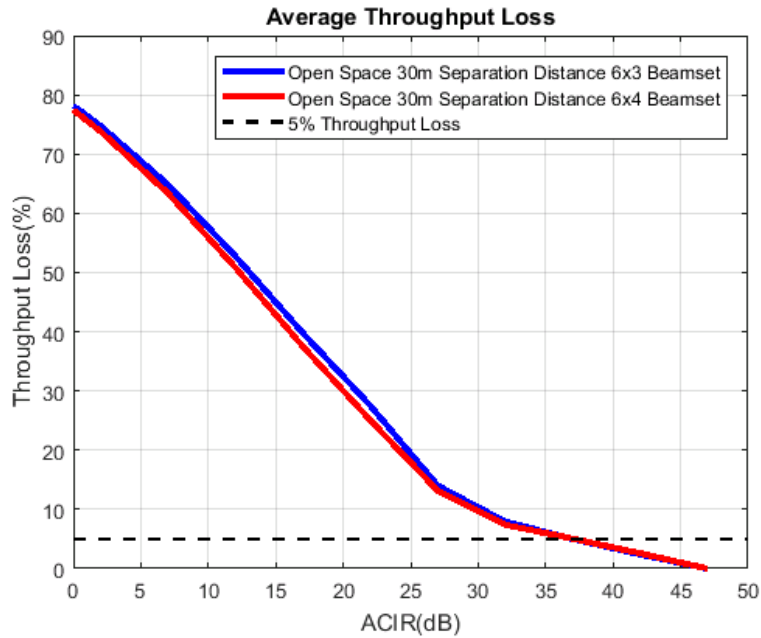

Figure 10: Impact of base station to base station interference on mean uplink throughput, outdoor hotspot with 15 m antenna height (ACIR) and 30 m offset between interferer and victim BS

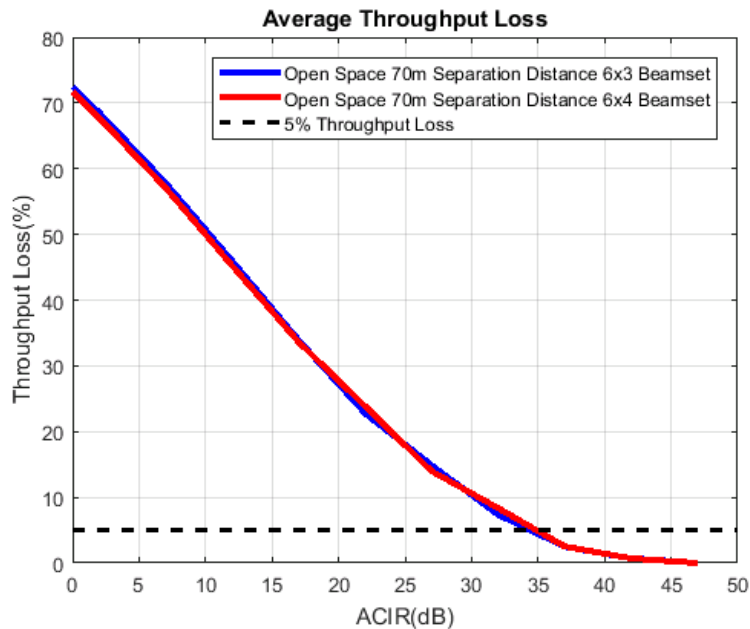

Figure 11: Impact of base station to base station interference on mean uplink throughput, outdoor hotspot with 15 m antenna height (ACIR) and 70 m offset between interferer and victim BS

Figure 12 and Figure 13 (for 30 m and 70 m offsets between the interferer base station and the victim base station respectively) show the estimated degradation of the mean uplink throughput of the victim MFCN

network due to base station to base station interference for the suburban open space scenario, presented as a function of the absolute OOB emission limit in dBm/MHz.

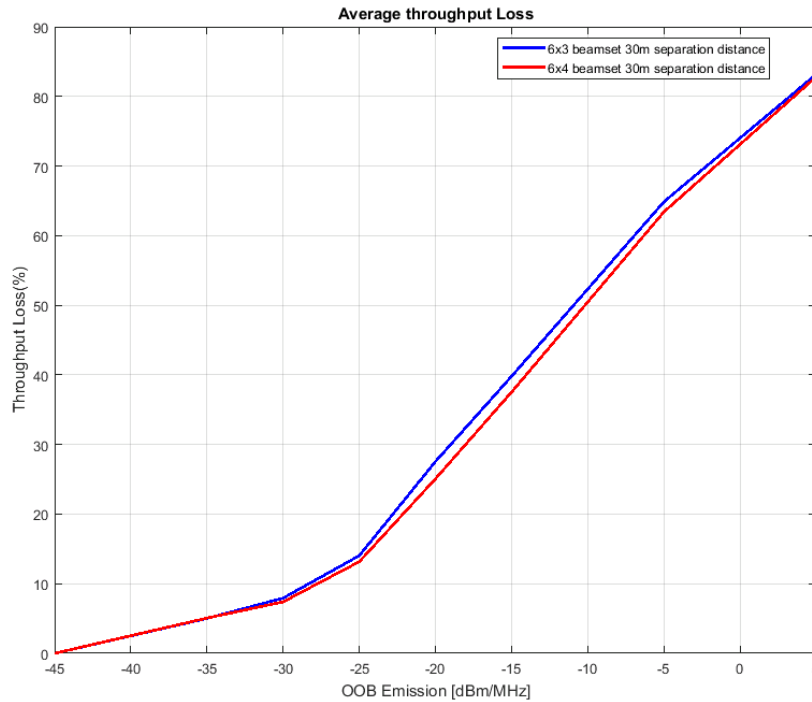

Figure 12: Impact of base station to base station interference on mean uplink throughput, outdoor hotspot with 15 m antenna height (OOB emission limit) and 30 m offset between interferer and victim BS

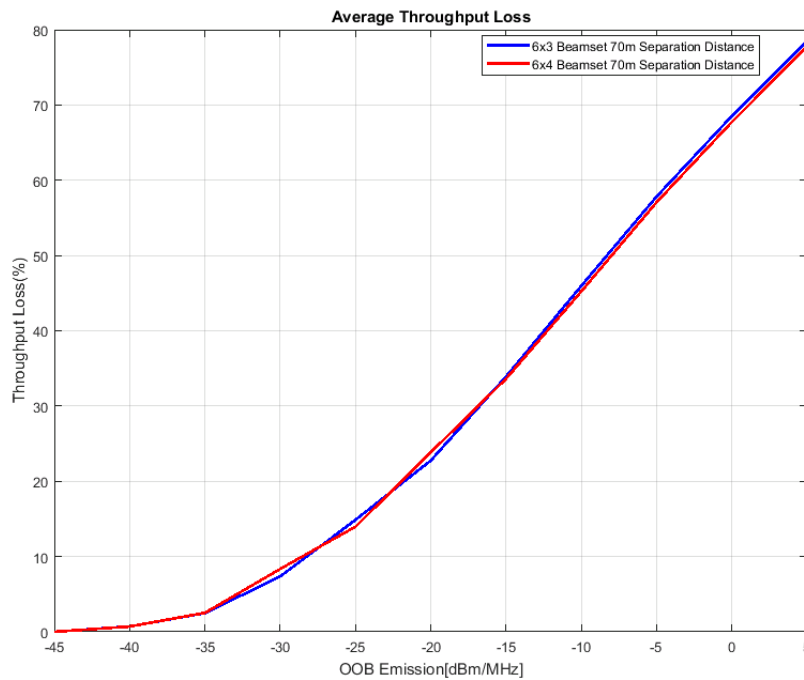

Figure 13: Impact of base station to base station interference on mean uplink throughput, outdoor hotspot with 15 m antenna height (OOB emission limit) and 70 m offset between interferer and victim BS

4.4.3 Summary of the simulation results in evaluation 2

Table 14 below presents the derived restrictions on the out-of-block emission levels of the interfering MFCN base station based on a target 5% degradation in the mean UL throughput of the victim MFCN base station, for the non-synchronised operation.

Note that the minimum required Adjacent Channel Leakage Ratio (ACLR) is assumed to be nominally equal to the required ACIR, with the understanding that the interference is not dominated by the adjacent channel selectivity (ACS) of the victim base station.

Table 14: Out-Of-Block (OOB) emission limits on interfering MFCN base station (outdoor vs. outdoor, uncoordinated locations, non-synchronised operation, up to 5% degradation in the mean uplink throughput of victim MFCN base station)

Interferer BS channel bandwidth	Victim BS channel bandwidth	In-block radiated power, TRP	Scenario	ACIR, min (dB) (~ACLR)	OOB emission limit (dBm/MHz)
200 MHz	200 MHz	25 dBm/200 MHz	Outdoor, 6 m antenna height, 30 m offset between interferer and victim BS	36...37	-35...-34
			Outdoor 15 m antenna height, 30 m offset between interferer and victim BS	37	-35
			Outdoor 15 m antenna height, 70 m offset between interferer and victim BS	34...35	-33...-32

In summary, the impact of the interference on the victim MFCN base stations performance diminishes with increasing values of ACIR or, equivalently, with the decreasing Out-Of-Block (OOB) emissions levels of the interfering MFCN base stations. It could be concluded from this evaluation that the Out-Of-Block emission limit of -35 dBm/MHz for MFCN base stations would ensure a coexistence of MFCN outdoor non-synchronised networks deployed in a non-coordinated manner and operating in the same or immediately adjacent geographical areas in all types of environments.

4.4.4 Separation distance analysis

Depending on the authorisation approach, it may be needed to assess the required separation distances between two geographically adjacent MFCN networks, both for co-channel and adjacent channel cases.

The topology is displayed in the following figure:

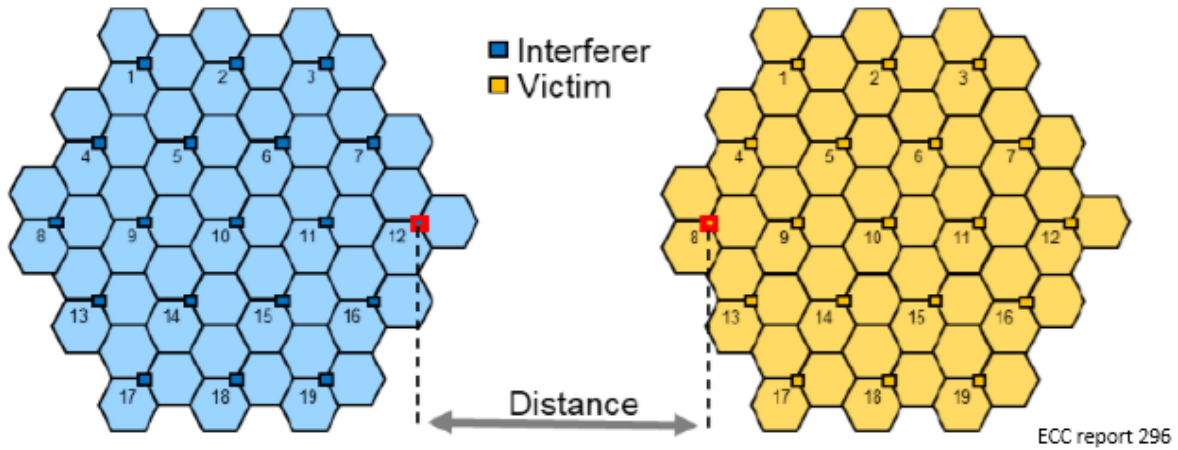

Figure 14: separation distance between MFCN networks

For calculation of these distances the relevant IMT-2020 BS parameters provided in Section 4.1.1 are assumed.

For the adjacent channel case, the absolute BEM from ECC Decision (18)06 (Annex 2, Tables 2 and 3) [1] is used in order to calculate the required separation distances between the closest BS of two geographically adjacent MFCN networks. Beyond these distances, which are scenario specific, the BEM from ECC Decision (18)06 could be used even in the case when MFCN networks are not synchronised. The required separation distances between the closest BS of two geographically adjacent MFCN networks for the co-channel case have also been assessed.

Urban/suburban hotspot scenario:

Figure 15 shows the estimated degradation of the mean uplink throughput of the victim MFCN network due to base station to base station interference in urban/suburban hotspot, presented as a function of separation distance (km) for co-channel.

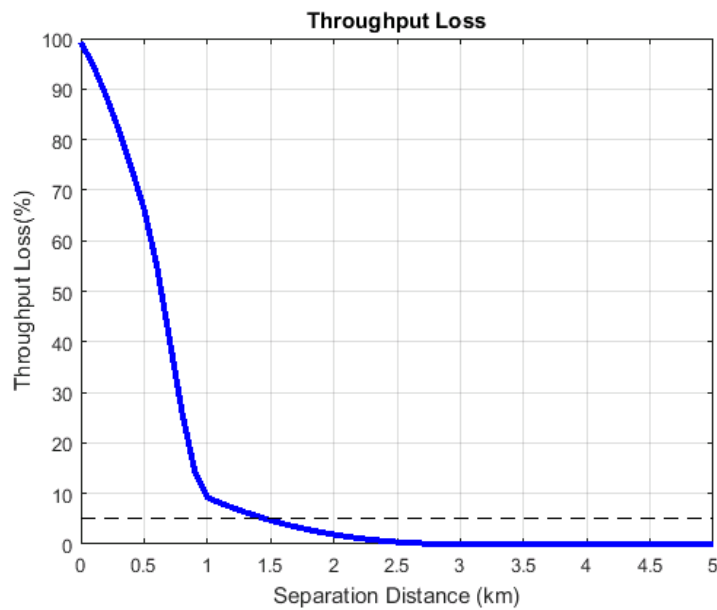

Figure 15: Impact of base station to base station interference on mean uplink throughput, outdoor hotspot with 6 m antenna height (Separation distance) for co-channel

Figure 16 shows the estimated degradation of the mean uplink throughput of the victim MFCN network due to base station to base station interference in outdoor hotspot 6 m antenna height, presented as a function of separation distance (km) for adjacent channel.

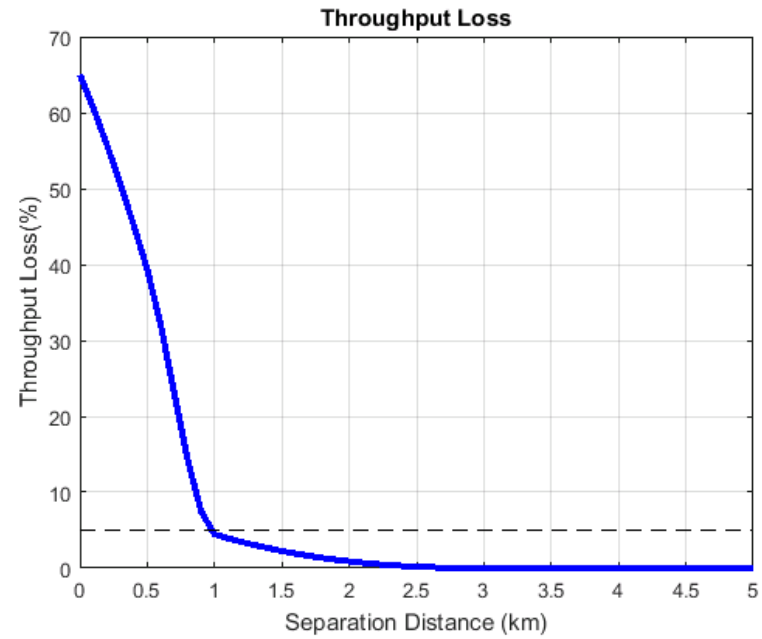

Figure 16: Impact of base station to base station interference on mean uplink throughput, outdoor hotspot with 6 m antenna height (Separation distance) for adjacent channel

Suburban open space scenario:

Figure 17 shows the estimated degradation of the mean uplink throughput of the victim MFCN network due to base station to base station interference in suburban open space, presented as a function of separation distance of co-channel.

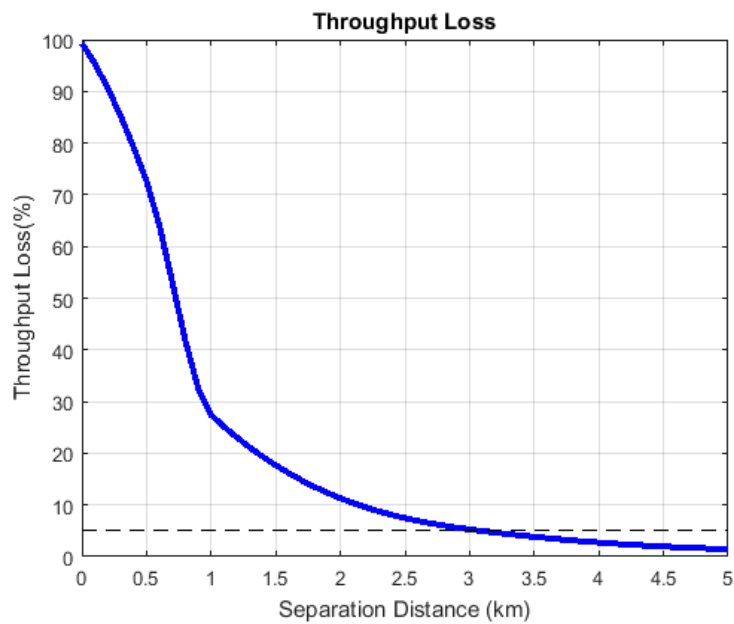

Figure 17: Impact of base station to base station interference on mean uplink throughput, outdoor with 15 m antenna height (Separation distance) for co-channel

Figure 18 shows the estimated degradation of the mean uplink throughput of the victim MFCN network due to base station to base station interference in suburban open space, presented as a function of separation distance of adjacent channel.

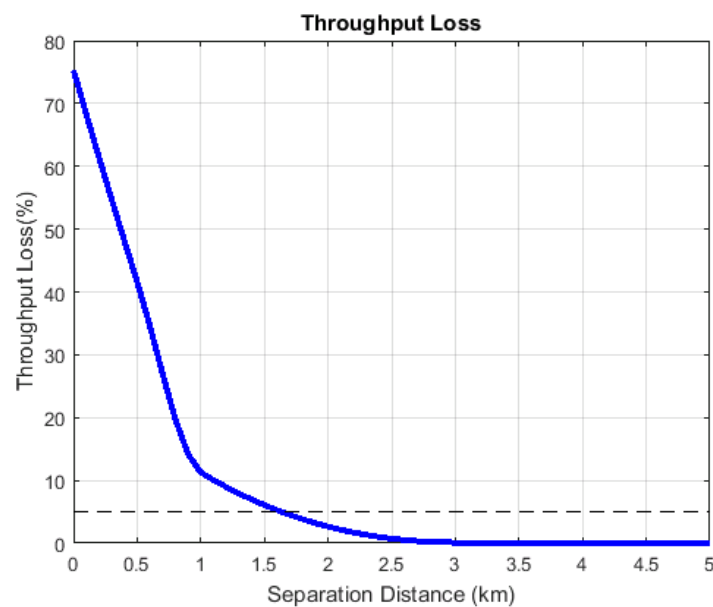

Figure 18: Impact of base station to base station interference on mean uplink throughput, outdoor with 15 m antenna height (Separation distance) for adjacent channel

Table 15 below presents the derived restrictions on the separation distances of MFCN base stations in co-channel and adjacent channel cases, based on a target 5% degradation in the mean UL throughput of the victim MFCN network, for the non-synchronised operation.

Table 15: Minimum separation distances for closest base stations of two geographically adjacent MFCN networks, non-synchronised operation (assuming 5% degradation in mean uplink throughput of victim MFCN network)

Interferer BS bandwidth	Victim BS bandwidth	In-block radiated power, TRP	Scenario	Separation distance (km)
200 MHz	200 MHz	25 dBm/(200 MHz)	Outdoor 6 m antenna height co-channel	1.5
			Outdoor 6 m antenna height adjacent channel	0.9
			Outdoor 15 m antenna height co-channel	3
			Outdoor 15 m antenna height adjacent channel	1.6

In summary, as it can be seen from the above analysis, the impact of the interference on the victim MFCN network performance diminishes with increasing values of separation distance.

It could be concluded that for co-channel scenarios 1.5 to 3 km of separation is required to meet the coexistence criterion of up to 5% degradation of uplink throughput.

For the adjacent channel scenario, 0.9 to 1.6 6 km separation will be required to meet the coexistence criterion of up to 5% degradation of uplink throughput.

4.5 EVALUATION 3 - OUTDOOR VS. OUTDOOR

4.5.1 Simulation parameters and propagation models

The parameters used are according to the ones shown in Section 4.1 with the following exceptions and the following selected options:

Table 16: IMT-2020 parameters used in the simulations

Parameter	Value
BS Antenna height (radiation centre)	6 m
Downtilt	10 degrees
Minimum distance between BS nodes (network shift)	One of 30, 50, 70 and 115 m
Offset angle between aggressor and victim BS	30 degrees
Antenna array configuration (Row × Column)	2x2
Maximum user terminal output power, $P_{C_{MAX}}$	11.4 dBm
Beamforming model	Beam pointing at the LOS direction of the served UEs
Path loss model	See Table 7

Assumptions on UE parameters are in agreement with simulation assumptions defined by ITU-R with the exception of UE antenna array configuration and UE output power. In this Report, a 2x2 UE antenna array and 11.4 dBm UE output power was considered to reflect the current development of the industry and 3GPP standard.

4.5.2 Simulation results

In this section, the UL throughput loss is evaluated in the outdoor vs. outdoor deployment for the two cases of fully unsynchronised and semi-synchronised operation. The two operators network layout is illustrated in Figure 2.

In the case of fully-unsynchronised operation, the impact of asynchronous BS to BS interference on the average UL throughput of the single operator network is shown in Figure 19 for different network shift values. From the results, it is seen that performance degrades very fast for network shifts below 80 m but, even in the worst case of 30 m network shift, it is possible to keep the target degradation within 5% by adopting baseline requirements in line with the ones defined for the synchronous case.

In the case of semi-synchronised operation, Figure 20 shows the average UL throughput loss in the worst case of 30 m network shift when 20% and 50% of the frame is synchronised. It is worth noticing that these results can also be used as a reference in the case two operators have fully unsynchronised (in terms of frame structure and alignment) operation but with opposite duplex directions for only 80% or 50% of the frame. In conclusion, the ACIR required to satisfy the 5% throughput loss condition narrows down already to 28 dB when two networks have opposite duplex directions for 80% of the time. The results correspond to the case in which UL to DL modifications are considered compared to the default frame structure, while in case of DL to UL modifications no additional interference compared to the sync case can be observed at the victim system.

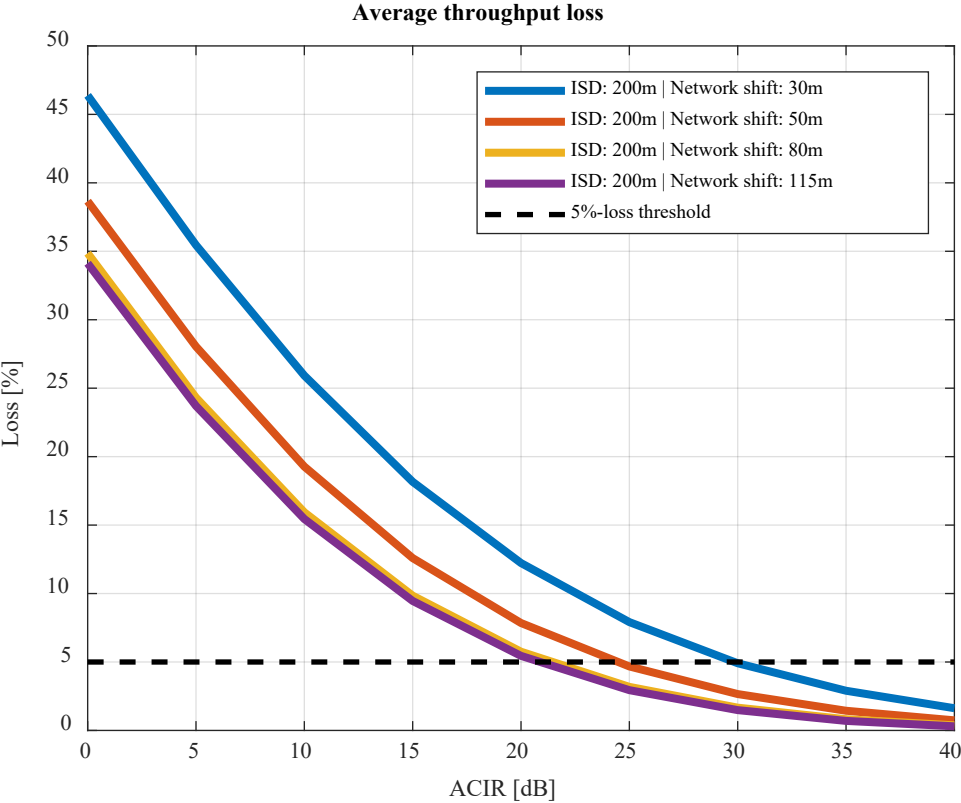

Figure 19: Average UL throughput loss in case of fully-unsynchronised operation

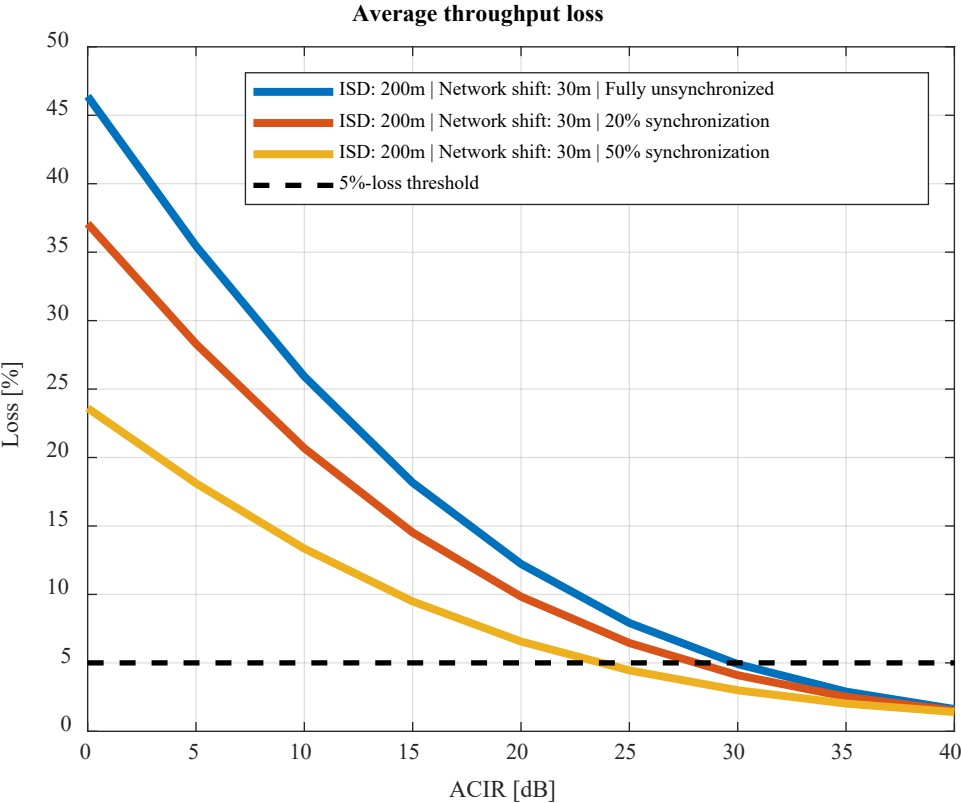

Figure 20: Average UL throughput loss in case of semi-synchronised operation

4.5.3 Separation distance analysis

A specific analysis to evaluate the outdoor vs. outdoor performance as a function of separation distance is carried in this section. The parameter settings adopted in this study are the same as described in section 4.5.1.

The main difference compared to the analysis in section 4.5.2 is the layout adopted in the simulation. In particular, two clusters made of 19 sites (57 tri-sectoral cells) are separated by a distance X metres. X represents the edge to edge distance in metres. Two slightly different cluster placements are shown in Figure 21. The figure shows edge to edge separation distance of 0 m (left column) and 500 m (right column), for methodology 1 (first row) and methodology 2 (second row). The two methodologies only differ in the placement of aggressor cluster and are simulated for completeness.

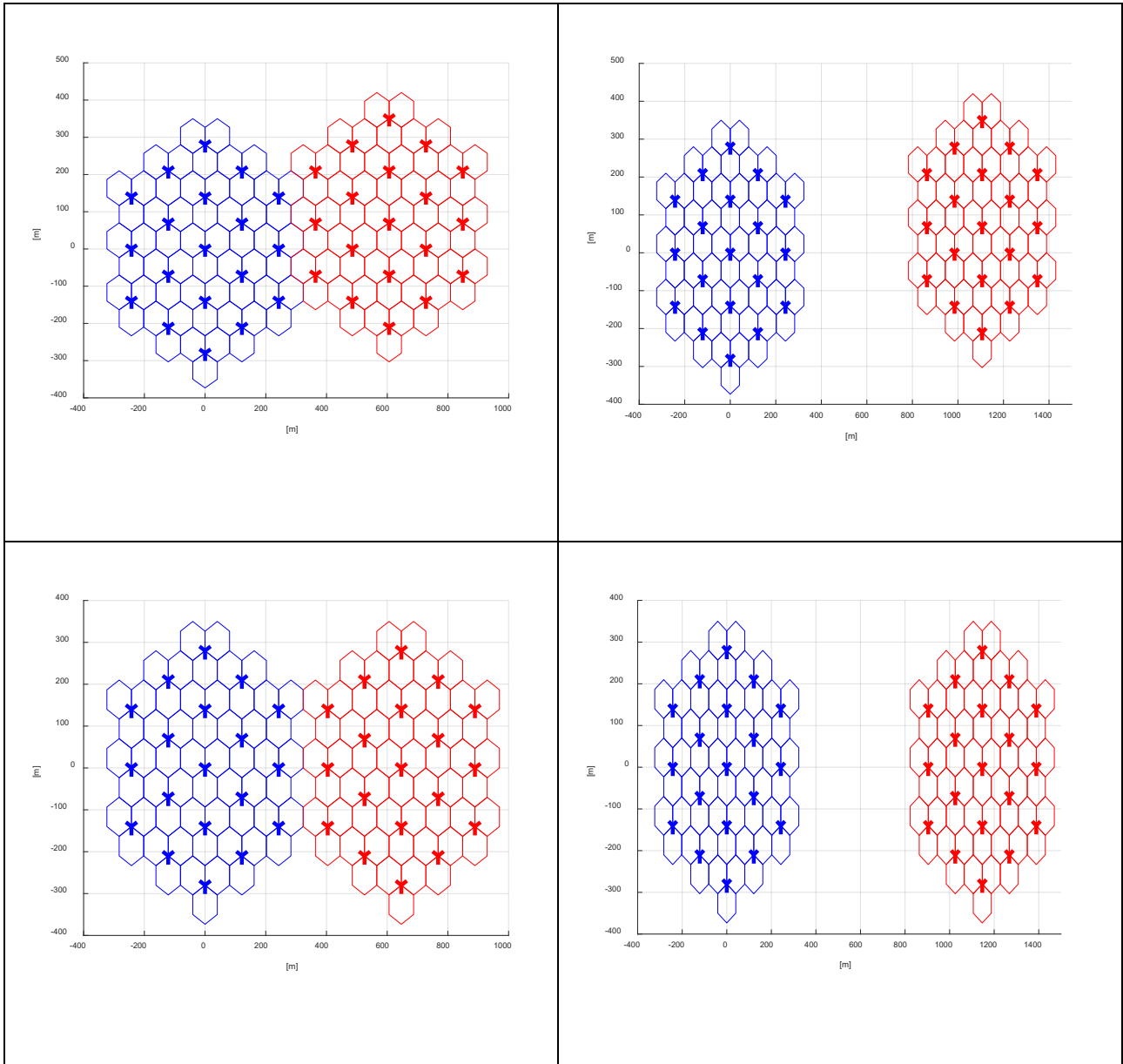

Figure 21: Separation distance analysis: methodology 1 and 2

In the following the focus is on outdoor hotspot scenario, i.e. the intention is to evaluate the cross interference of two cluster of base stations (hotspots) deployed in urban/suburban environment and separated by a distance of X metres (distance between the closest base bastions belonging to the different clusters).

Compared to the separation distance analysis in section 4.4.4, the two main differences are the path loss adopted in BS to BS link and beam selection in the BS-UE link. Regarding the path loss model, since it has been assumed that the two clusters both belong to urban-like environment, the Report ITU-R M.2412-0 [11] path loss model is adopted as described in Table 6. The rationale is to adopt a single path loss model for BS-BS both within cluster and between clusters.

Regarding the beam selection, the 3GPP RAN4 assumptions in 3GPP TR 38.803 were followed,[9] i.e. a beam is generated pointing to the LOS direction between the BS and the corresponding scheduled UE. This set up was the one used to generate the 3GPP core RF requirements. The rationale is simply BS and UE from different vendors might use a different codebook, so the selection of a codebook is an arbitrary choice. Furthermore, having a beam pointing directly to the UE might help creating an average effect across different possible scenarios (different codebook, different BS antenna heights and different BS downtilt angles).

Figure 22 shows the mean throughput degradation performance as a function of the edge to edge separation distance. Both co-channel operation and adjacent channel operation with ACIR=28 dB are considered. The ACIR assumption is based on the 3GPP specification of 28 dB Adjacent Channel Leakage Ratio (ACLR). The results are averaged across all base stations in the cluster. As it can be observed, methodology 1 and methodology 2 shows very similar performance. The impact of adjacent channel operation in case of separate clusters is negligible as expected from the analysis carried out in section 4.5.2. The case analysed in 4.5.2 is for networks in the same area and for that case the impact is also relatively small.

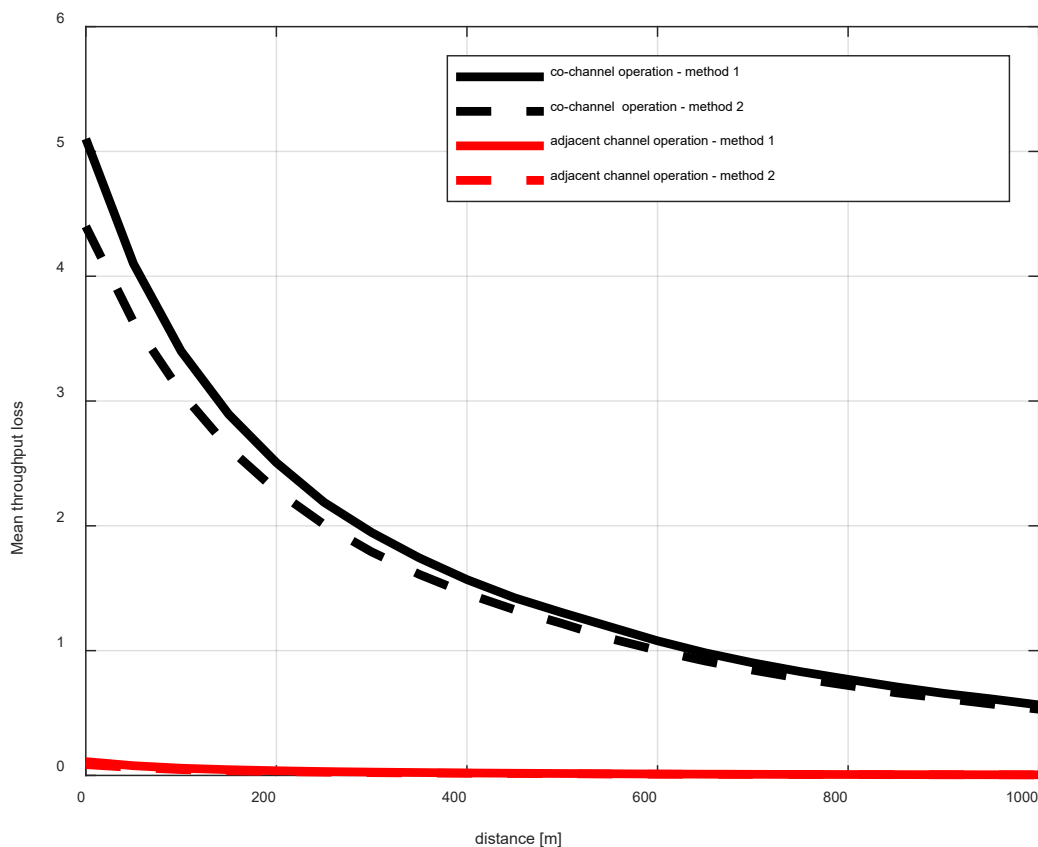

Figure 22: Separation distance analysis - average results across the cluster

In order to evaluate the impact in the worst-case scenario, statistics were also collected per base station. Figure 23 shows the co-channel performance as a function of the edge to edge separation distance for methodology 1 (the one leading to worst results). As it can be observed, a separation of 600 m will allow to keep the mean throughput degradation within 5%. Another interesting observation is related to the performance trend for different base stations. From the picture, two groups of base stations can be distinguished:

- one group of base station with good performance even for small separation. This group corresponds to the base station whose sector is not pointing to the aggressor cluster;
- one group of base station with worse performance. This group corresponds to the base station whose sector is pointing to the aggressor cluster.

As a consequence, the separation distance between two clusters can be highly reduced by appropriate base station installation.

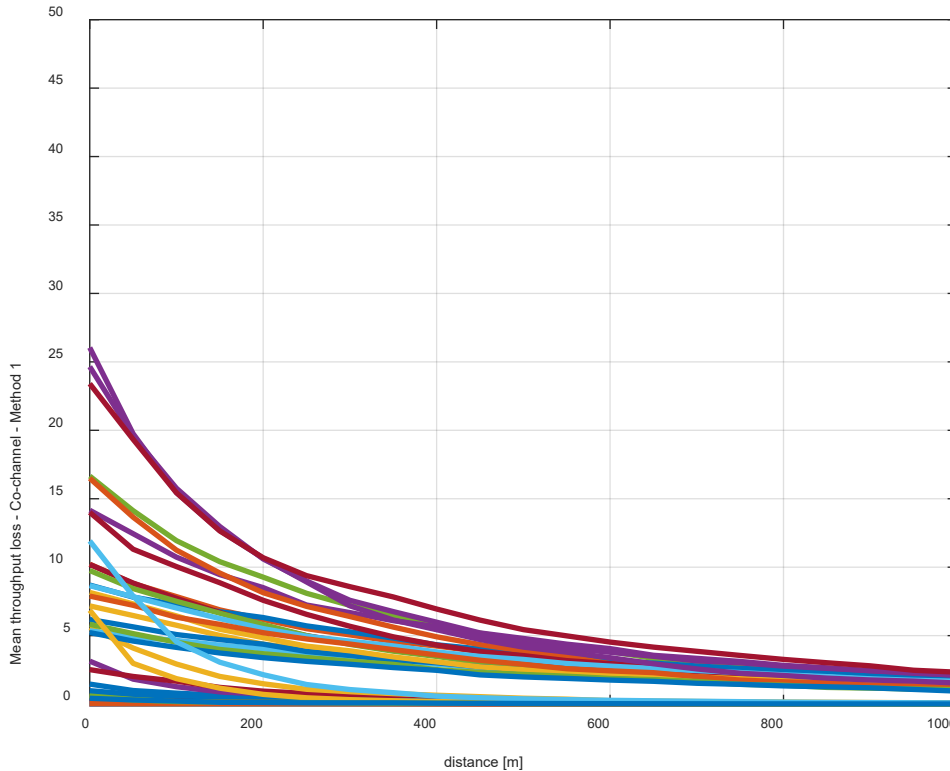

Figure 23: Separation distance analysis - co-channel operation. Results are organised per base station. Each colour represents one base station in the cluster.

In the following, an adjacent channel study has been considered with the same configuration described in Figure 21 (for the sake of simplicity only method 1 is considered which brings to slightly worse performance). In particular, two different ACIR value are considered:

ACIR = 11 dB. Based on the TRP assumptions in this Report this ACIR would correspond to an emission level in line with the ECC decision baseline mask.

ACIR = 28 dB. This is the agreed Adjacent Channel Leakage Ratio (ACLR) requirement in 3GPP specification and the one adopted in previous analysis.

Figure 24 shows the mean throughput degradation as a function of the separation distance for adjacent channel operation with an ACIR=11 dB. Each line in the figure represents a different victim BS in the cluster. As it can be observed, for the worst performing BS, a separation distance of 150 m allows to keep the mean throughput degradation within 5%. For the sake of completeness, the average performance across BS (average cluster performance) is also shown in dashed blue line.

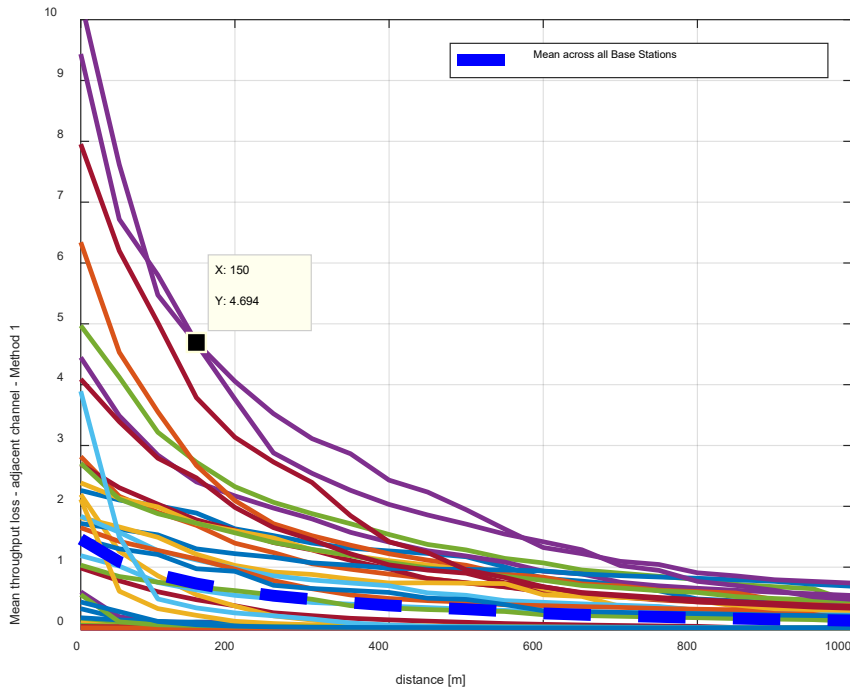

Figure 24: Separation distance analysis - adjacent-channel operation - results organised per base station (ACIR=11 dB). Each colour represents one basestation in the cluster

If the case of ACIR=28 dB is analysed, i.e. BS compliant with the 3GPP RAN4 Adjacent Channel Leakage Ratio (ACLR) requirement, no noticeable performance degradation can be observed even at very short separation distance. This is consistent with the results presented in 4.3.2 and 4.5.2 where it is shown that with an ACIR~28 dB asynchronous operation is possible in the same geographical area, provided a minimum distance in the order of 50 to 80 metres).

Table 17: Summary of cluster to cluster separation distance analysis in urban environment

Scenario	Required minimum separation distance to keep mean throughput degradation within 5%
Urban clusters: co-channel operation	Cluster separation: >600 m
Urban clusters: asynchronous adjacent channel operation with ACIR = 11 dB (equivalent TRP assumptions in this Report and the ECC Decision baseline)	Cluster separation: >150 m
Urban clusters: asynchronous adjacent channel operation with ACIR = 28 dB (equivalent to 3GPP ACLR minimum requirement)	Asynchronous adjacent operation is possible within the same cluster provided that a minimum BS to BS distance is satisfied (in the order of 50 to 80 metres according to sections 4.3.2 and 4.5.2)

In summary, the analysis presented in this section is consistent with the outdoor to outdoor analysis presented in sections 4.3.2 and 4.5.2, while larger separation distances is reported in section 4.4.4.

4.6 EVALUATION 4 - OUTDOOR VS. INDOOR

4.6.1 Simulation parameters and propagation models

The parameters used are according to the ones shown in Section 4.1 with the following exceptions and the following selected options:

Table 18: IMT-2020 parameters used in the simulations

Parameter	Value
Deployment	Case 1 (short wall facing the BS) Case 2 (long wall facing the BS)

4.6.2 Simulation results

The uplink throughput is evaluated in the outdoor vs. indoor deployment. Two cases are evaluated with the short wall facing the BS (case 1) and the long wall facing the BS (Case 2). The system layout is illustrated in Figure 4.

The impact of the outdoor network on the indoor network is shown in Figure 25 and Figure 26. The same reasoning regarding the realisation of the BS-BS propagation is applied as in Evaluation 1. The results show that an average throughput loss of less than 5% is always achieved for an ACIR of 20 dB.

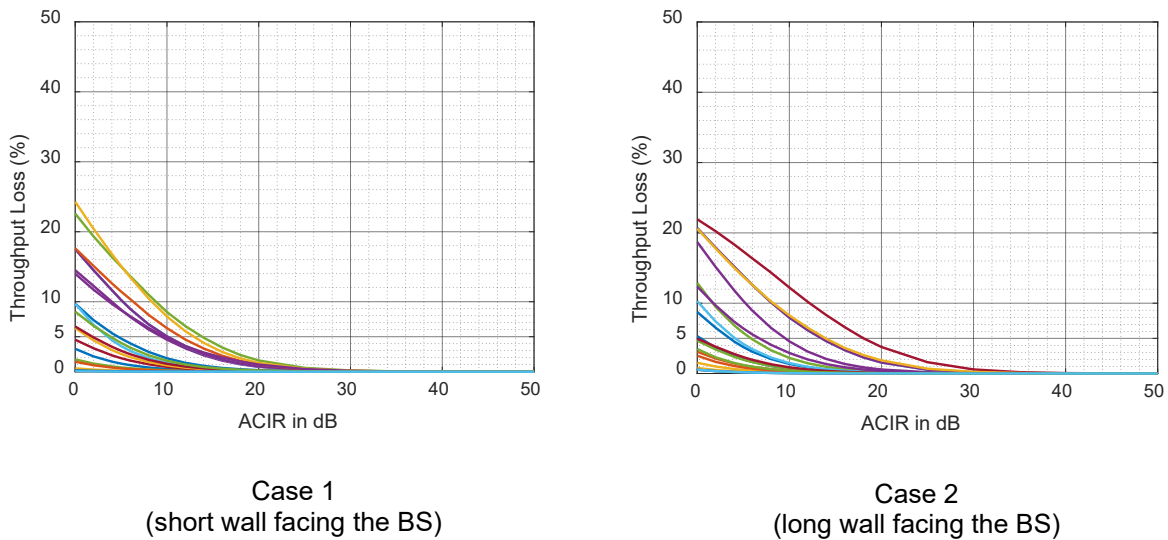

Figure 25: Uplink throughput loss for the indoor network. Throughput loss in each curve averaged over many realisations of the Macro BS serving different users. Each curve represents one realisation of the outdoor-to-indoor propagation

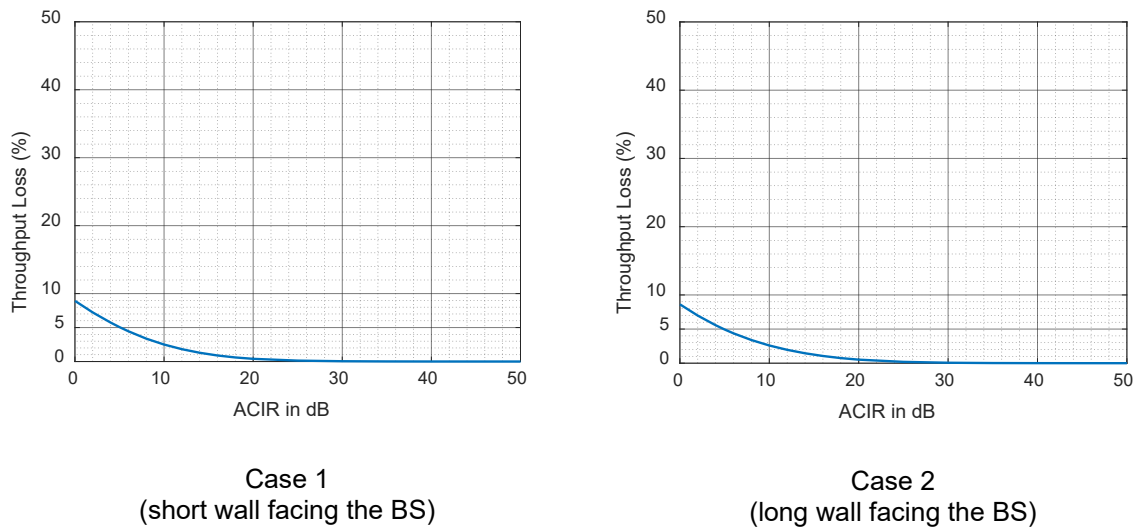

Figure 26: Average uplink throughput loss for the indoor network. Throughput loss averaged over different outdoor-to-indoor channel realisations and the interfering Macro BS serving different users

4.7 EVALUATION 5 - OUTDOOR VS. INDOOR

4.7.1 Simulation parameters and propagation models

The parameters used are according to the ones shown in Section 4.1 with the following exceptions and the following selected options.

Table 19: IMT-2020 parameters used in the simulations

Parameter	Value
Deployment	Case 2 (long wall facing the BS)
Antenna array configuration (Row × Column)	2x2
Maximum user terminal output power, $P_{C_{MAX}}$	11.4 dBm

Assumptions on UE parameters are in agreement with simulation assumptions defined by ITU-R with the exception of UE antenna array configuration and UE output power. In this Report, a 2x2 UE antenna array and 11.4 dBm UE output power was considered to reflect the current development of the industry and 3GPP standard.

4.7.2 Simulation results

The uplink throughput is evaluated in the outdoor vs. indoor deployment. The impact of asynchronous BS to BS interference on the average UL throughput of the single operator Indoor network is shown in Figure 27 and it is negligible for every value of ACIR. Based on these results, it has been concluded that in this scenario asynchronous operation is possible even in the case of co-channel operation.

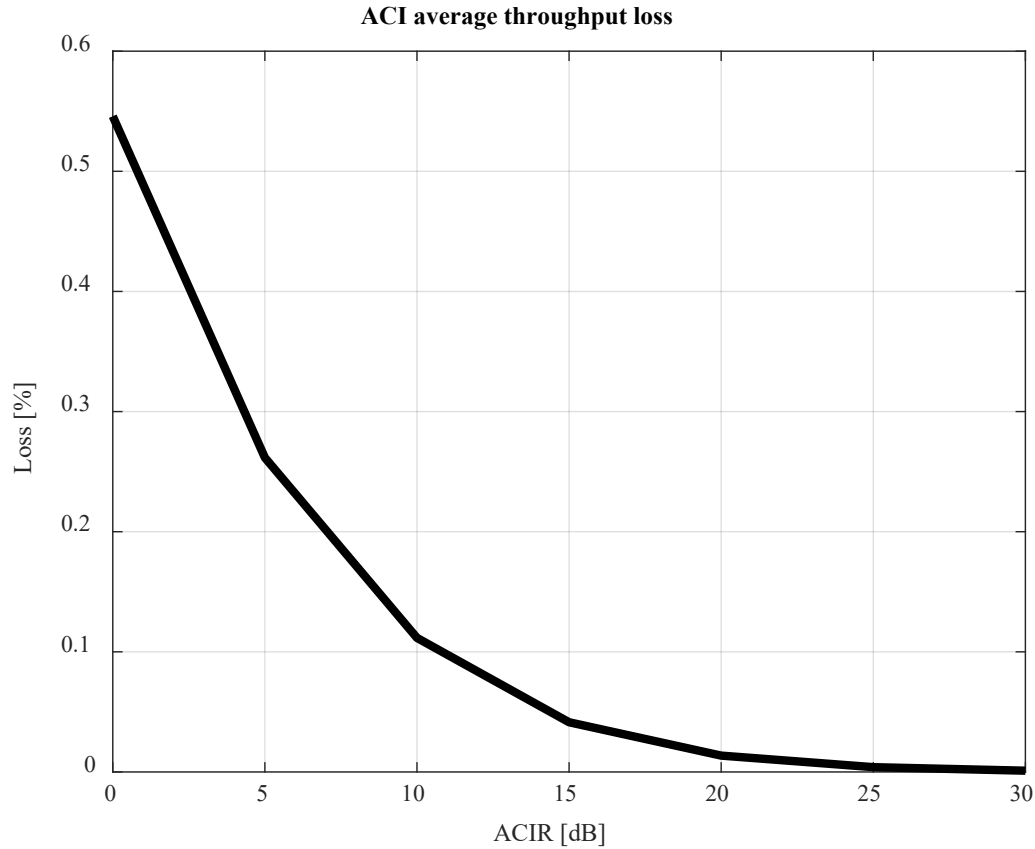

Figure 27: Average UL throughput loss for the Indoor network due to a synchronous BS to BS interference

4.8 EVALUATION 6 - INDOOR VS. INDOOR

4.8.1 Simulation parameters and propagation models

The parameters are fully in line with the ones shown in section 4.1.

4.8.2 Simulation results

In Figure 28 and Figure 29, the results of the simulations are shown. In Figure 28, the results for several realisations of the BS-BS propagation are shown and these are averaged in Figure 29. The results show that there is less than 5% throughput loss for ACIR larger than 22 dB.

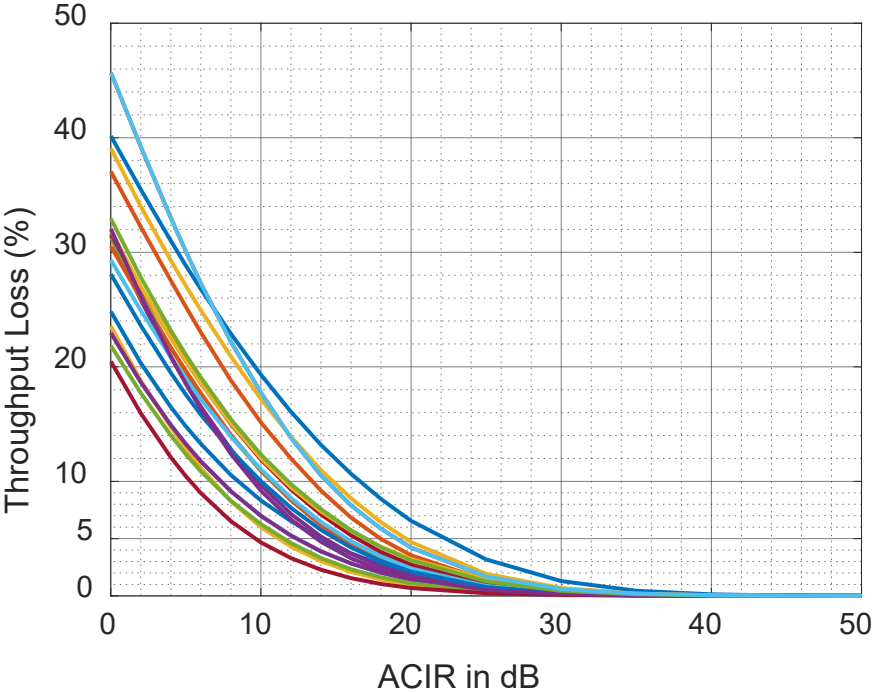

Figure 28: Uplink throughput loss averaged over all users for different realisations of the BS-BS channel model

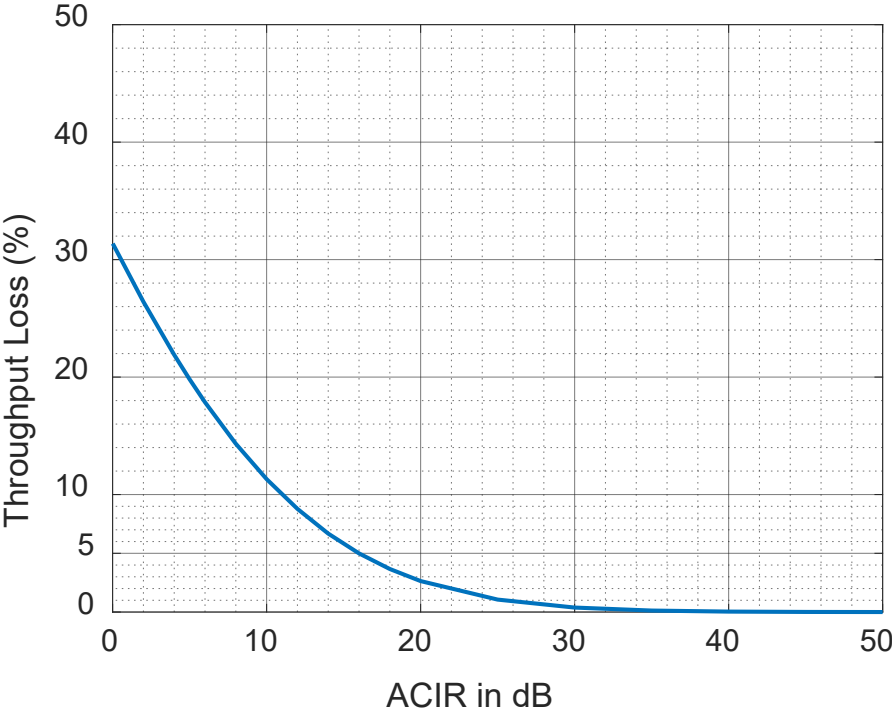

Figure 29: Average uplink throughput loss

4.9 EVALUATION 7 - INDOOR VS. INDOOR

In this section, the UL throughput is evaluated in the indoor vs. indoor deployment. The parameters used are according to the ones shown in Section 4.1. The two operators' network layout is as described in section 4.2.3. Propagation BS-to-UE and BS-to-BS is modelled as described in Table 20.

Table 20: Indoor-to-indoor propagation models

Link	Propagation model
BS-UE	Report ITU-R M.2412 [11]
BS-BS	Free-space path loss

4.9.1 Simulation results

The impact of asynchronous BS to BS interference on the average UL throughput of the single operator network is shown in Figure 30. Based on these results, it is concluded that in this scenario fully-asynchronous operation is possible with baseline equipment performance.

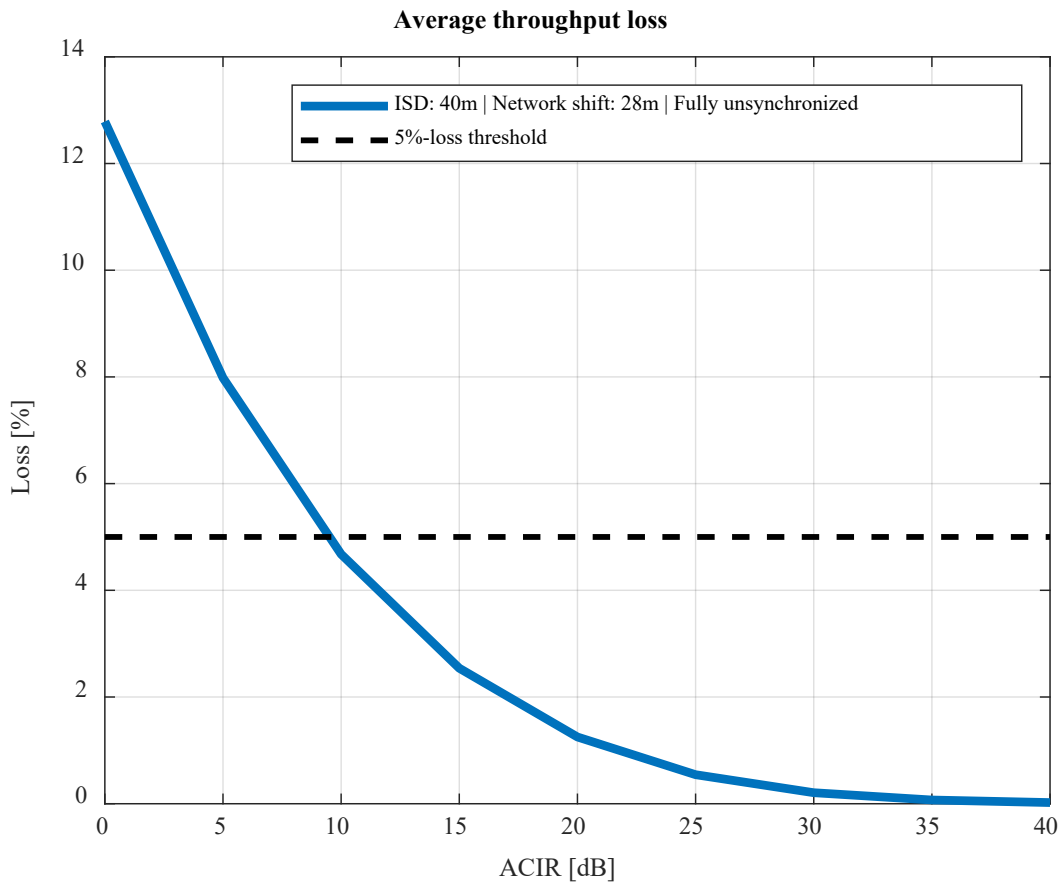

Figure 30: Average uplink throughput loss

5 ANALYSIS AND SYNTHESIS

5.1 BASELINE PERFORMANCE SPECIFICATIONS

The total interference caused in one channel by transmitters in an adjacent channel depends on both the emissions in the adjacent channel caused by the interfering transmitter as well as the ability of the receiver to suppress (strong) signals in the adjacent channel. These two effects are combined into what is known as the adjacent channel interference ratio (ACIR) (clause 5.2.6 of [9]). The ACIR can be calculated as follows for two systems of the same bandwidth:

$$ACIR = \frac{1}{\frac{1}{ACLR} + \frac{1}{ACS}}$$

The values for Adjacent Channel Selectivity (ACS) and Adjacent Channel Leakage Ratio (ACLR) can be found in the technical specifications of the systems. For NR the levels given are 28 dB for ACLR (Table 9.7.3.3-1 of [10]) and 23 dB for ACS (Table 10.5.1.3-1 of [10]).

It should however be noted that sharing studies in adjacent channels only take the effect of unwanted emissions into account. This is reasonable since licensing conditions normally only specify the OOB emission limits. This means that in only the ACLR requirement is used when determining the ACIR limits with the understanding that interference is not dominated by the adjacent channel selectivity (ACS) of the victim base station. Thus 28 dB is used as the ACIR level for determining requirements for coexistence while ACS is assumed to be close to ideal, i.e. $ACS \gg ACLR$.

A consequence of the above assumption is that the studies in the Report do not account for the possible blocking effect due to base station to base station interference. At the deployment stage, additional consideration should be given by the mobile operators to the risk of blocking effect due to close location of the respective base stations antennas.

Two of the main envisioned service categories for 5G are enhanced mobile broadband (eMBB) and ultra reliable and low latency communication (URLLC) services.

For eMBB the main performance measure is throughput, either measured as capacity in a cell or as the datarate that can be achieved by a specific user. Since this has been the predominant service for quite some time the measurements and requirement levels are well established. It is quite common to use 5% throughput loss as the limit when conducting sharing studies between MFCN networks. In practice this means that some of the transmissions are lost, but there are mechanisms for detecting packet losses and retransmitting that so that all data eventually reaches the receiver.

For URLLC the performance measures are not as well established. One observation is that for services that rely on extremely short latency there is no time to perform retransmissions. This means that more stringent requirements should be applied compared to the eMBB case.

5.2 SCENARIO COMPARISON

5.2.1 Indoor vs. (outdoor and indoor) scenarios

The results for all studies with at least one indoor deployment are summarised in Table 21 below. It can be noted that all the results show that sharing is possible for adjacent channel cases (ACIR=28 dB). For co-channel cases (ACIR=0 dB) there are a few cases when sharing is possible.

There are no evaluations done for the case with an indoor aggressor and an outdoor victim. However this case is less stringent than the outdoor vs. indoor cases listed below since the indoor BS output power is less than the outdoor BS output power.

Table 21: Summary of indoor results

Evaluation number	Aggressor	Victim	ACIR for 5% throughput loss
Evaluation 4	Outdoor system	Indoor system	0-18 dB
Evaluation 5	Outdoor system	Indoor system	0 dB
Evaluation 6	Indoor system	Indoor system	10-22 dB
Evaluation 7	Indoor system	Indoor system	10 dB

5.2.2 Outdoor vs. outdoor scenarios

The results for evaluations with both networks deployed outdoor is shown in Table 22 below.

Table 22: Summary of outdoor vs. outdoor evaluations

Evaluation number	Separation distance (m)	Degree of synchronisation (%) UL to DL modification NOTE: DL-UL no change	ACIR for 5% throughput loss (dB)
Evaluation 3	30	50	24
Evaluation 3	30	20	28
Evaluation 1	30	0	24-33
Evaluation 2	30	0	36-37
Evaluation 3	30	0	30
Evaluation 1	50	0	25
Evaluation 3	50	0	25
Evaluation 1	70	0	22
Evaluation 2	70	0	34-35
Evaluation 3	80	0	22
Evaluation 1	115	0	20
Evaluation 3	115	0	21

6 TOOLBOX: OPTIONS FOR ADMINISTRATIONS TO SUPPORT THE DESIGN OF SYNCHRONISATION FRAMEWORKS AT NATIONAL LEVEL

6.1 OPTIONS FOR AGREEMENTS

For many options outlined here there is a need to agree among the license holders in the band. Depending on the regulatory framework decided the agreements may need to be facilitated by the regulator. What needs to be agreed and the various possibilities for reaching an agreement are discussed in detail in ECC Report 296 [3] in section 5.3.

Qualitatively the issues in the 26 GHz band are the same as in the 3.5 GHz band although the exact levels, distances etc. are different. Thus, this Report focuses on the quantitative differences related to carrier frequency.

6.2 OPTIONS FOR INDOOR DEPLOYMENTS

For the case with a network operating inside a specific building there is no need to synchronise the network to other networks (indoor and outdoor), if the networks are using adjacent channels.

It may be possible for an outdoor network and an indoor network to use the same channel if careful planning is used and if the envisioned service is eMBB. For URLLC services it may be challenging to use the same channel.

6.3 OPTIONS FOR OUTDOOR DEPLOYMENTS

6.3.1 Geographic separation

Unsynchronised operation of two geographically adjacent MFCN networks is feasible in case the separation distances between them are greater than those in the following table:

Table 23: Separation distances between two geographically adjacent MFCN networks for unsynchronised operation

Scenario	Separation distance Adjacent channel	Separation distance co-channel
Outdoor hotspot, 6 m antenna height (with high clutter loss)	150 m	600 m
Outdoor hotspot, 6 m antenna height (with low clutter loss)	900 m	1.6 km
Outdoor hotspot, 15 m antenna height	1.5 km	3 km

6.3.2 Networks with separation less than above

When the minimum separation distances are less there are three different options:

6.3.2.1 Option 1: Synchronised networks

The networks can be synchronised. The baseline limits from the ECC Decision 18(06) applies.

6.3.2.2 Option 2: Semi-synchronised networks

The networks can be semi-synchronised. Semi-synchronised operation would give the flexibility to the mobile operators to adjust the UL/DL ratio to the actual traffic. The baseline limits from the ECC Decision 18(06) [1] applies on the condition of a proper agreement among all involved mobile operators on the following (see Section 6.1):

- a common phase clock reference, as for synchronised operation;
- partial frame alignment: the agreement shall define a default frame structure as for synchronised operation (for which UL/DL directions are defined across the whole frame) and at the same time the part of the frame where each operator is allowed to reverse the default transmission direction (flexible part);

For the flexible part two different set of modifications can be implemented:

- UL to DL modifications:
 - From BS-BS perspective the simulations have shown that it is preferable in order to maintain the cross-link interference within acceptable limits, it is preferable to upper limit the UL to DL modifications compared to the default frame structure.
 - No additional MS-MS interference is expected for this type of modifications.
- DL to UL modifications
 - In this case, from BS-BS interference perspective, the network that modifies the default DL transmission direction into UL will not interfere with the other network, while it will receive additional interference from the other network¹.
 - In most circumstances, MS-MS interference will be negligible because terminals typically transmit intermittently, and many will be mobile so any interference would be transient. It is expected that some 5G use cases will imply the deployment of MSs that are in fixed positions and close to each other (e.g. crowded stadiums, trains, busses). In some of those specific scenarios, the MS-MS interference might not be negligible anymore: no specific studies were performed with this respect. However, compared to sub 6 GHz bands in mmWave UE performs beamforming therefore the probability of two MS beams pointing at each other is expected to be low.

6.3.2.3 Option 3: Restricted baseline limit

Instead of using the baseline limits the BS emissions should meet a restricted baseline limit of -13 dBm/50 MHz depending on the assumptions in section 4.14.1. A minimum separation between BS of 50-80 metres has to be respected.

The state of the art at the time when this report was developed does not allow meeting the restricted baseline limits without use of guard bands. The restricted baseline limit is not part of 3GPP specifications.

¹ In case of DL to UL, modifications compared to the default frame structure, no additional interference compared to the synchronuous case can be observed at the victim system.

7 CONCLUSIONS

This Report provides the options for synchronisation framework, in particular, to enable unsynchronised and semi-synchronised operation of MFCN in the 24.25-27.5 GHz band.

The Report concludes that for indoor deployments using adjacent channels unsynchronised operation is possible using equipment complying to the baseline requirements. I.e. for indoor deployments it is not necessary to synchronise two networks. This is under the assumption of an authorisation regime, where base station locations are planned and proper installation of indoor base stations can guarantee the assumed building entry loss of the interfering signal. I.e. the indoor installation should be professionally done to ensure sufficient isolation between indoor and outdoor systems.

It may be possible for an outdoor network and an indoor network to use the same channel if careful planning is used and if the envisioned service is eMBB. For URLLC services it may be challenging to use the same channel.

For outdoor deployments of two geographically adjacent MFCN networks, depending on the specific scenario (urban, suburban and open space) and on the co-channel or adjacent channel case, unsynchronised operation is feasible respecting certain minimum separation distances between the edges of the two networks as described in section 6.3.

Table 24: Separation distances between two geographically adjacent MFCN networks for unsynchronised operation

Scenario	Separation distance Adjacent channel	Separation distance co-channel
Outdoor hotspot, 6 m antenna height (with high clutter loss)	150 metres	600 metres
Outdoor hotspot, 6 m antenna height (with low clutter loss)	900 metres	1.6 km
Outdoor hotspot, 15m antenna height	1.5 km	3 km

When the separation distances are less than those values, there are three different options:

- The networks can be synchronised. The baseline limits from the ECC Decision 18(06) applies;
- The networks can be semi-synchronised. The baseline limits from the ECC Decision 18(06) applies on the condition of a proper agreement on the semi-synchronised pattern among all involved mobile operators;
- Instead of using the baseline limits the BS emissions should meet a restricted baseline limit of -13 dBm/50MHz, implying use of guard bands². A minimum separation between BS of 50-80 metres has to be respected.

A synthesis of the different synchronisation options is shown in the following figures:

² The state of the art at the time when this report was developed does not allow meeting the restricted baseline limits without use of guard bands. The restricted baseline limit is not part of 3GPP specifications.

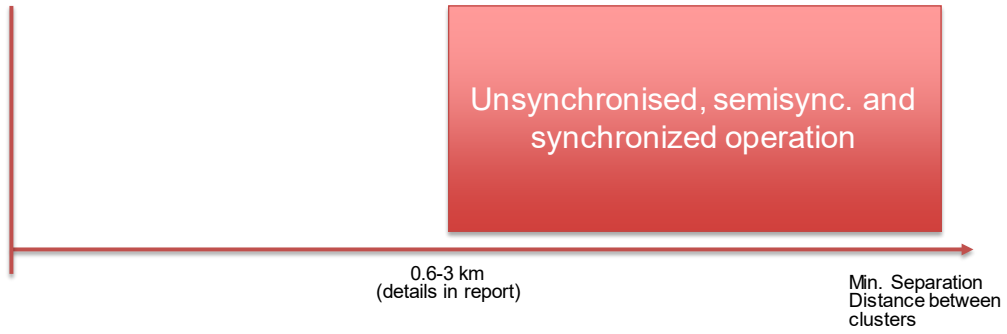

Figure 31: Synopsis of the different synchronisation options in outdoor deployments for co-channel operation

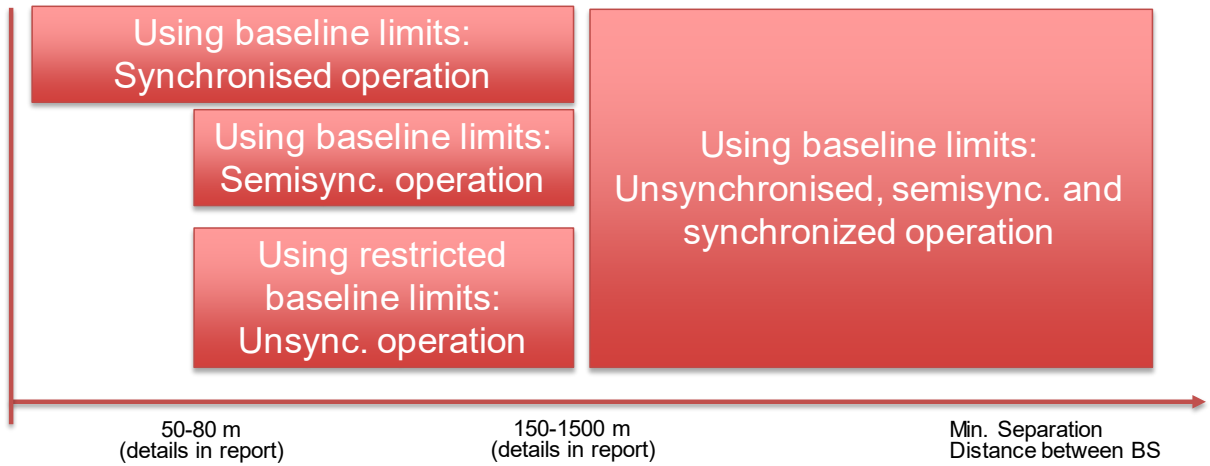

Figure 32: Synopsis of the different synchronisation options in outdoor deployments for adjacent-channel operation

ANNEX 1: LIST OF REFERENCES

- [1] ECC Decision (18)06: "Harmonised technical conditions for Mobile/Fixed Communications Networks (MFCN) in the band 24.25-27.5 GHz", October 2018"
- [2] CEPT Report 068: "Report B from CEPT to the European Commission in response to the Mandate "to develop harmonised technical conditions for spectrum use in support of the introduction of next-generation (5G) terrestrial wireless systems in the Union". Harmonised technical conditions for the 24.25-27.5 GHz ('26 GHz') frequency band", July 2018"
- [3] ECC Report 296: "National synchronisation regulatory framework options in 3400-3800 MHz: a toolbox for coexistence of MFCNs in synchronised, unsynchronised and semi-synchronised operation in 3400-3800 MHz", January 2019
- [4] ECC Report 216: "Practical guidance for TDD networks synchronisation", August 2014
- [5] ECC Report 281: "Analysis of the suitability of the regulatory technical conditions for 5G MFCN operation in the 3400-3800 MHz band", July 2018
- [6] ECC Decision (11)06: "Harmonised frequency arrangements and least restrictive technical conditions (LRTC) for mobile/fixed communications networks (MFCN) operating in the band 3400-3800 MHz", October 2018
- [7] ECC Report 203: "Least Restrictive Technical Conditions suitable for Mobile/Fixed Communication Networks (MFCN), including IMT, in the frequency bands 3400-3600 MHz and 3600-3800 MHz", November 2013
- [8] ECC Recommendation (15)01: "Cross-border coordination for mobile/fixed communications networks (MFCN) in the frequency bands: 694-790 MHz, 1452-1492 MHz, 3400-3600 MHz and 3600-3800 MHz", February 2016
- [9] 3GPP TR 38.803: "Study on new radio access technology: Radio Frequency (RF) and co-existence aspects", May 2016
- [10] 3GPP TS 38.104: "NR; Base Station (BS) radio transmission and reception", September 2017
- [11] Report ITU-R M.2412-0 (10/2017): "Guidelines for evaluation of radio interface technologies for IMT-2020"
- [12] Recommendation ITU-R P.2109-0 (06/2017): "Prediction of building entry loss"
- [13] Recommendation ITU-R M.2101-0 (02/2017): "Modelling and simulation of IMT networks and systems for use in sharing and compatibility studies"
- [14] Recommendation ITU-R P.525-3 (09/2016): "Calculation of free-space attenuation"