



ECC Report **293**

Mobile Spectrum Monitoring Units

08 February 2019

0 EXECUTIVE SUMMARY

This ECC Report gives an overview of different types and models of the mobile spectrum monitoring units, which are used to carry out the radio monitoring tasks by the Administrations and Radio Monitoring Services in CEPT countries.

This document includes:

- The main concepts of the mobile spectrum monitoring units and vehicles used;
- The equipment used in the mobile spectrum monitoring units in CEPT countries;
- Technical design of the mobile spectrum monitoring units and arrangement of equipment in the vehicle;
- Considering of electromagnetic compatibility in the vehicle.

General requirements for functionality and technical specifications of the mobile spectrum monitoring units are described in Recommendation ITU-R SM.1723-2 [1]. Structures and appropriate design of different mobile spectrum monitoring unit types are provided in the Spectrum Monitoring Handbook [2].

The purpose of this ECC Report is to support administrations considering further development of new mobile spectrum monitoring units by providing examples of existing measurement vehicles.

TABLE OF CONTENTS

0	Executive summary	2
1	Introduction	5
2	GENERAL CONCEPTS OF MOBILE MONITORING UNITS.....	6
3	THE VEHICLES FOR MOBILE SPECTRUM MONITORING UNITS	8
3.1	Requirements for vehicles, used for mobile spectrum monitoring units	8
3.2	The main types of vehicles used for mobile spectrum monitoring units	8
3.2.1	Passenger cars, SUVs, MPVs	8
3.2.2	Vans, heavy-duty utility vans, minibuses, buses, light trucks (≤ 3.5 tons).....	9
3.2.3	Trucks (> 3.5 tons).....	10
3.2.4	Trailers	10
3.3	Engineering design of mobile spectrum monitoring units.....	11
3.3.1	Main approaches of vehicle integration	11
3.3.2	Overview of mobile spectrum monitoring units equipment	13
4	ANTENNAS FOR MOBILE SPECTRUM MONITORING UNITS.....	15
4.1	The requirement for antennas arrangement.....	15
4.2	Monitoring and measuring antennas for mobile spectrum monitoring units	15
4.3	Direction finding antennas for mobile spectrum monitoring units.....	19
5	ANTENNA MAST AND ROTATORS	22
5.1	Antenna mast types	22
5.2	Position of the antenna mast	22
5.3	Control and indication of antenna mast operation, movement and positioning.....	25
5.4	Antenna feeder and supply cable fixing.....	25
5.5	Antenna azimuth polarisation and elevation.....	26
5.6	Video surveillance.....	26
5.7	Possibility to install additional antennas	27
5.8	Levelling system of the mast	29
6	MEASURING AND MONITORING EQUIPMENT	33
7	POWER SUPPLY	37
8	REQUIREMENTS FOR ADDITIONAL AND SPECIALISED EQUIPMENT.....	39
8.1	Information technologies used for the mobile spectrum monitoring units	39
8.2	Navigation equipment and frequency normal	39
8.3	Additional equipment	40
9	EMC IN THE VEHICLE.....	41
10	Design features of mobile spectrum monitoring units	42
10.1	Onboard arrangement of working space	42
10.2	Air conditioning	48
10.3	Vehicles design features.....	48
11	OTHER ISSUES	49
11.1	Registration of the vehicles, rule-books and instruction manuals	49
11.2	The mobile spectrum monitoring units challenge	50
	ANNEX 1: List of References.....	51

List of abbreviations

Abbreviation	Explanation
AGM	Absorbent Glass Mat
CEPT	European Conference of Postal and Telecommunications Administrations
CDMA	Code Division Multiply Access
DC	Direct Current
DF	Direction Finding, Direction Finder
ECC	Electronic Communications Committee
EHF	Extra High Frequencies
EMC	Electromagnetic compatibility
EMF	Electro-Magnetic Field
GNSS	Global Navigation Satellite System
GSM-1800	Digital Communication System (in the frequency range 1800 MHz)
GPS	Global Positioning System
IT	Information Technology
LTE	Long Term Evolution
MPV	Multi-Purpose Vehicle
PC	Personal computer
RR	Radio Regulations
SHF	Super High Frequencies
SMH	Spectrum Monitoring Handbook
SUV	Sport Utility Vehicle
TETRA	TErrestrial Trunked RAdio
VHF	Very High Frequencies
UHF	Ultra High Frequencies
UMTS	Universal Mobile Telecommunications System
W-CDMA	Wideband CDMA
Wi-Fi	Wireless Fidelity

1 INTRODUCTION

In accordance with the Radio Regulations (RR), the tasks of the monitoring service are as follows [3]:

- monitoring of emissions for compliance their parameters with frequency assignment conditions;
- frequency band observations and frequency channel occupancy measurements;
- investigation of interference cases;
- identification and elimination of unauthorised emissions.

Additionally, these tasks the Radio Monitoring Service is often charged with the following tasks not directly derived from the RR:

- assistance on special occasions such as major sporting events and state visits;
- radio coverage measurements;
- radio compatibility and EMC studies;
- technical and scientific studies, i.e. driven by the International Telecommunication Union (ITU);
- EMF measurement inspections of radio stations.

Types and total number of spectrum monitoring equipment in the Radio Monitoring Service depend on its tasks and national level of telecommunication technologies development.

Radio Monitoring Services carry out spectrum monitoring by fixed monitoring stations, mobile spectrum monitoring units and portable equipment usage.

Fixed monitoring stations cover a fixed service area for monitoring in the certain frequency band, primary, up to 6 GHz. However, the service area of fixed station is limited in range. Consequently, in most cases the fixed monitoring stations cannot provide spectrum monitoring of new telecommunication technologies, since the radiation power of these technologies is often very low.

In comparison to fixed stations, mobile spectrum monitoring units can be moved and make measurements close to the emitters, for example, such with low power level, high transmission directivity and/or high frequency emission.

More information on interoperation between the fixed monitoring stations and the mobile spectrum monitoring units is given in Recommendation ITU R SM.1537 [4].

A mobile spectrum monitoring unit consists of a vehicle fitted with mobile monitoring station equipment that can be used in manual or automatic mode.

Mobile spectrum monitoring station is a complete set of:

- equipment, including monitoring, measuring and direction finding devices;
- monitoring, measuring and/or direction finding antennas;
- ancillary equipment, arranged on the vehicle;
- antenna mast, if necessary;
- power supply system.

This ECC Report presents information on different types and models of the mobile spectrum monitoring units, which national Administrations and Radio Monitoring Services in CEPT countries are equipped with or which are the advanced developments.

2 GENERAL CONCEPTS OF MOBILE MONITORING UNITS

Administrations and Radio Monitoring Services take into account a lot of factors while selecting mobile spectrum monitoring units, which can meet their needs.

Design, technical specification and set of equipment for the mobile spectrum monitoring units vary considerably according to their purposes and functionality. So the following factors should be considered before a mobile spectrum monitoring unit is selected:

- purpose and functionality of a mobile spectrum monitoring unit;
- operating frequency band;
- equipment required;
- conditions, in which a vehicle will operate (within the cities or in rural areas, hilly or flat terrain, paved roads or off-roads);
- various commercial vehicles or specially designed vehicles should be used.

Basic information on mobile spectrum monitoring units is provided in the Spectrum Monitoring Handbook (SMH) [2] and Recommendation ITU-R SM.1723-2 [1].

A mobile spectrum monitoring unit can be used to perform the following assigned spectrum monitoring tasks:

- to search and detect radio emissions;
- to carry out direction finding and geolocation of radio emission sources, which locate beyond the service areas of fixed monitoring stations;
- to search and detect illegal radio transmitter interference sources, when it is impossible to take measurements by fixed stations within their service areas due to the high directivity of antennas, high operating frequencies and particular wave propagation characteristics;
- to carry out spectrum occupancy measurements;
- to get more accurate radio transmitter geolocation within the fixed monitoring station service areas.

There are two general concepts of mobile spectrum monitoring units:

- general purpose mobile spectrum monitoring unit; and
- specialised (or, - special-purpose) mobile spectrum monitoring unit.

The general purpose mobile spectrum monitoring units have a broad range of use and provide spectrum monitoring of many telecommunication technologies, for example:

- amateur radio;
- mobile radio telephone service;
- sound and video broadcasting.

In some cases the general purpose mobile spectrum monitoring unit can be equipped with the direction finder to carry out direction finding and geolocation of radio transmitters within their operating frequency bands.

The specialised mobile spectrum monitoring units fulfil nonstandard tasks. Due to special equipment the possibilities of the technical evaluation of the given signals is a lot deeper compared to general purpose vehicles. Evaluation and decoding of the following telecommunication technologies are examples for special tasks:

- mobile cellular networks and mobile cellular base stations;
- wideband networks and wideband communication base stations;
- fixed service transmitters and radio-relay stations;
- earth stations of satellite services, etc.

In addition specialised vehicles also operate under covered conditions. These vehicles are disguised and appear to be for example as recreation vehicles and even have exchangeable licence plates. The tasks of these monitoring units are mainly to discover intended and illegal transmitters such as "radio pirates".

3 THE VEHICLES FOR MOBILE SPECTRUM MONITORING UNITS

3.1 REQUIREMENTS FOR VEHICLES, USED FOR MOBILE SPECTRUM MONITORING UNITS

Mobile monitoring unit can be developed from a variety of commercial vehicles. A commercial vehicle with standard drive train components will offer the lowest life cycle costs. It is better to buy vehicles from manufacturers who have local service centres already in place. Vehicles intended for use on unpaved roads and off-road need four-wheel drive and sufficient road clearance.

The vehicles should meet the national regulations referring to the cars/vans/trucks and comply with all the mandatory national acts and rules.

Vehicles should be equipped with the required number and type of fire extinguishers as per the national regulations (e.g. National Traffic and Motor Vehicle Safety Act). It is recommendable to have one extra extinguisher for the electrical equipment.

3.2 THE MAIN TYPES OF VEHICLES USED FOR MOBILE SPECTRUM MONITORING UNITS

The main types of vehicles, proper for the mobile monitoring units, are described in the SMH [2].

In practice the Radio Monitoring Services in CEPT countries use different types of passenger cars, Vans, SUVs, minivans and minibuses or buses.

The main types of vehicles used are as follows:

Type 1: Passenger cars, SUVs, MPVs

Type 2: Vans, heavy-duty utility vans, minibuses, buses, light trucks (≤ 3.5 tons)

Type 3: Trucks (> 3.5 tons)

The type of vehicle and vehicle cabin body concept which is used depends on the tasks of mobile spectrum monitoring unit, the needful equipment, the use environment etc. The used type of vehicle defines which driving licence will be necessary. The national regulations are different among the countries. In general it can be said, that trucks (type 3) need a special driving licence.

3.2.1 Passenger cars, SUVs, MPVs

Passenger cars, SUVs, minivans, MPVs, i.e. vehicles with maximum load capacity of about 500kg are the most commonly used types. They have some advantage of being highly manoeuvrable in the settlements and having low fuel consumption comparing to vans or trucks.

This type is used for the general purpose and specialised mobile spectrum monitoring units as well.

Mobile monitoring stations, installed on this type of vehicles, may be successfully used for the following tasks:

- to search and detect radio transmitter emissions and mobile interference sources;
- to measure radio transmitter emission parameters and characteristics;
- to identify the radio emissions;
- to carry out frequency bands observations and frequency occupancy measurements.

In case this vehicle type is equipped with the direction finder, the direction-finding antenna can be disguised as luggage and antennas of a lower sensitivity can even be completely integrated into the vehicle roof so as not to be recognised.

The following Type 1 vehicles are used by Radio Monitoring Services in the CEPT countries:

- Passenger car Skoda Fabia;
- SUVs: Volkswagen Touareg, Toyota Landcruiser, Mercedes G270 (G300, G313, G320), Nissan Pathfinder, SsangYong Rexton, Mitsubishi Pajero, Volvo XC90, Fort Transit Connect, Renault-Duster, Renault Logan, Mercedes-Benz G30

Normal vehicle heater and air conditioner will be sufficient for such vehicles. Air conditioning of a vehicle, if necessary, can be powered from an electric main of a vehicle.

In the most cases vehicles have four-wheel-drive (4WD).

3.2.2 Vans, heavy-duty utility vans, minibuses, buses, light trucks (≤ 3.5 tons)

Heavy-duty utility vans, minibuses, buses and light trucks (i.e. vehicles with the kerb weight of maximum 2.8 tons) are intended for use as universal vehicles in off-road conditions and have four-wheel drive (4WD) and sufficient road clearance.

Type 2 vehicles are used for the general purpose and specialised mobile spectrum monitoring units as well.

The following vehicles can be used as carrier vehicles:

- minibuses: Mercedes Sprinter 416D (315CDI, 316D, 319CDI), Renault Master, Ford Transit Goods Wagon; Fiat DUCATO, Volkswagen Crafter, Fiat Scudo, Mercedes-Benz Vito etc.;
- Vans: Volkswagen Transporter T4 (T6);
- Light Truck: Toyota Hilux D/Cabin;
- Waggon truck Renault Traffic 2.5 DCI.

This type of vehicles can be equipped with a telescopic mast compatible with the difficult road condition.

Mobile monitoring stations, installed on this vehicle type, can be fitted with measuring equipment, mast and direction finders with antenna, and offer space for additional antennas and a portable power generator in the rear part of the vehicle.

As general purpose mobile spectrum monitoring units they are successfully used:

- to search and detect radio transmitter emission and mobile sources of interference;
- to measure radio transmitter emission parameters and characteristics;
- to identify radio emissions;
- to carry out frequency bands observation and to take frequency channel occupancy measurements;
- to carry out direction finding of radio transmitters and emission sources;
- to carry out radio transmitters geolocation.

In concept of special-purposed mobile spectrum monitoring units they provide:

- spectrum monitoring, identification, investigation and measurement of coverage area and QoS of mobile cellular networks and mobile cellular base stations;
- measurement of fixed service transmitters and radio-relay stations parameters;
- search of interference cases for earth stations of satellite services;
- search of interference cases in the wideband networks and wideband base stations.

3.2.3 Trucks (> 3.5 tons)

Trucks can be chosen for arrangement of mobile monitoring station equipment to carry out long-term or quasi-stationary or standalone measurements.

Radio Monitoring Services in the CEPT countries do usually not use this type of vehicles for mobile spectrum monitoring units. This can be explained due to the fact, that there are not enough applications for these types of vehicles. Furthermore it can be stated, that the measurement technologies became much smaller in recent years, consequently the vehicles can become smaller as well.

The situations when such trucks are used are of that matter, that the monitoring task endures several days and that a long distance is in-between the location where to measure and the home base. Examples for these tasks are major events. Here the advantage of the larger space within a truck can be used for informal meetings of engineers of the administration, other authorities, like police officers or with customers to set up short term licences.

3.2.4 Trailers

The use of trailers can be compared to the use of trucks. Trailers are beneficial in situations when long-term, quasi-stationary or standalone measurements are carried out. Furthermore, depending on the size of the trailer it can be used to fulfil measurement tasks at major events. If the trailer is of a certain size it can provide a workspace with a desk and several chairs.

If the trailer is equipped with batteries or a Diesel generator and a complete set of monitoring equipment it also can be used as a transportable monitoring station to support in an area where temporarily monitoring is necessary.

The following benefits of a trailer set up can be pointed out:

- Reduced complexity – Evidently trailers do not include propellant systems and other systems that provide safety for passengers and a driver while on move.
- Flexible size – Trailers and their monitoring unit parts can be chosen in accordance of planned task. They can be as small as a 19 inch rack for unattended monitoring or they may be larger to accommodate a working space.
- Longer lifetime – In practice it can be seen that a vehicle has a shorter lifetime than trailers. Thus trailer based monitoring units have the advantage that due to their longer life-time the equipment may be used longer without any modifications.
- Reduced personnel for unattended operation – In comparison to a vehicle the driver of a deployed trailer monitoring unit can drive himself back to office without need for an additional car and driver.

The noted benefits of trailer monitoring units lead to cost efficiency, however these benefits appear the most when the trailer setup is used as a transportable fixed monitoring station, which means, that it will remain at a fixed position for a longer period of time.



Figure 1: Trailer monitoring unit (Switzerland)

3.3 ENGINEERING DESIGN OF MOBILE SPECTRUM MONITORING UNITS

Mobile spectrum monitoring units are equipped with complex devices and equipment of different manufacturers.

In the CEPT countries different types of mobile spectrum monitoring units are used. Their functional and technical possibilities should comply with telecommunications development level and provide monitoring and measuring of present day and new telecommunication technologies as well. For this reason an administration has to modernise the mobile spectrum monitoring units and radio monitoring equipment frequently.

3.3.1 Main approaches of vehicle integration

If an administration wants to set up a new fleet of mobile spectrum monitoring units it first needs to think about if a fully developed measurement vehicle will be bought at a supplier ("of the shelf") or if the administration will do large parts of the works by external manufacturers, or by local company, or by itself.

If the Administration makes a decision for the “of the shelf” approach, it needs to examine the market situation to choose a full service provider that offers a fully developed mobile spectrum monitoring units. Consequently the provider takes care about all aspects like power supply, mast operation, arrangement of devices, the field of human engineering and all other parts. However, the administration should be able to influence some aspects to adapt the mobile spectrum monitoring unit to its needs.

In contrast to “of the shelf” the “in-house development” approach can be defined. Here an administration develops most characteristics of the vehicle on its own. This will yield to a mobile spectrum monitoring unit that will almost completely match the requirements of the administration. To perform such development a project team with a broad technical knowledge need to be installed. Some parts of the project like the installation of the chosen mast system into the vehicle can be done by an external company.

Radio Monitoring Services in the most CEPT countries use following types of vehicle integration approaches:

- by a separate external specialist company or cars rebuild company, for example, like for some mobile monitoring vehicles in Czech Republic, Latvia, Lithuania, Switzerland;
- by national manufacturers or by local company in line with the Service’ needs (turnkey), for example, in Bulgaria, Cyprus, Hungary, Lithuania, Montenegro, Netherland, Sweden, Ukraine;
- by national Radio Monitoring Services (“In-house development” approach), for example, in Slovenia, Montenegro.

In the most cases national Radio Monitoring Services (for example, in Germany, Lithuania, Latvia, Ukraine etc.) are projecting the development on their own and the implementation is done by cars rebuild companies. The interior arrangement (position of the drawers, cupboards, racks and mast) can be developed by a project group and fitted by a van accessory specialist. The Radio Monitoring Service buys vehicles and defined equipment, a local company finally builds a mobile spectrum monitoring unit in line with Radio Monitoring Service needs.

Figure 2 shows the workflow diagram to create a mobile spectrum monitoring unit when following the “in house development” approach. With it, most important steps can be seen when developing a new measurement vehicle. However it may have to be adapted by a project team of an administration to fit specific needs.

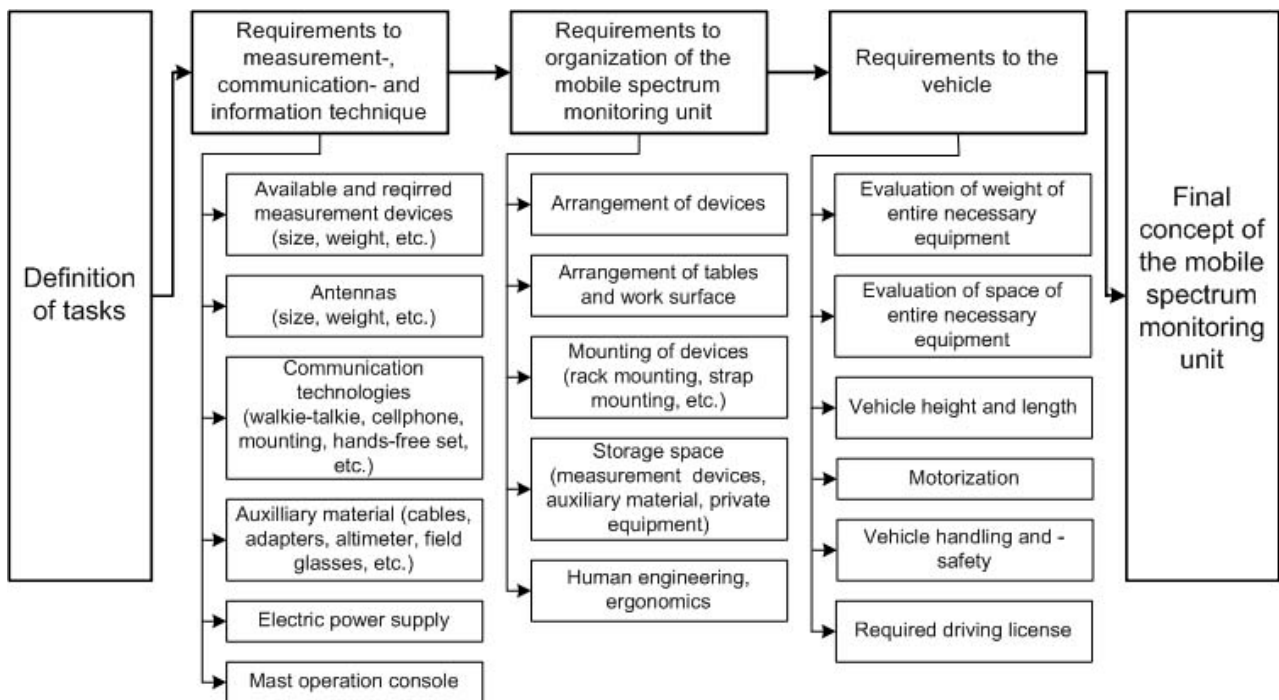

Figure 2: Workflow diagram to create a mobile spectrum monitoring unit concept

The workflow diagram shows the crucial steps to create a concept of a mobile spectrum monitoring unit. First step is the definition of tasks that will be fulfilled when using the mobile spectrum monitoring unit. These tasks are usually given by law, like laws in the EMC or in the telecommunication act. They also can be given by external customers, for example, if an administration provides a payed service to telecommunications providers. Tasks are also may be defined by administrative assistance that is possibly given to police or other administrations in major events.

When the tasks have been clarified and well defined three requirements have to be evaluated:

- measurement-, communication- and information technique requirements;
- organisational of the measuring station;
- vehicle requirements.

When considering all aspects of the workflow diagram large parts of the concept have been determined. However, every administration will have specific needs and focal points which can only be considered by an own project team.

3.3.2 Overview of mobile spectrum monitoring units equipment

Like explained an administration can either develop large parts of the mobile spectrum monitoring units on its own or it will accept the offer of a full service provider. Especially in the case of self-development an administration needs to have an overview of all equipment which will be carried on the car.

The Table 1 shows a possible approach how an administration can get this overview of required equipment. It can be seen, that the first three columns represent a general and detailed description of the type of equipment. Since the frequency range is a key factor of many devices it is given in column number four. Column five to eight deal with dimensions and weight of the equipment. When self-developing a mobile spectrum monitoring unit this information is of high importance. The sum of the weight for instance will give the projecting team a crucial indicator for the type of the vehicle (SUV, Van, truck ...) which will be selected later in the project.

Table 1: List of approximate measurement, monitoring equipment and accessories used in mobile spectrum monitoring units

Category	Equipment Type	Frequency Range	Length mm	Height mm	Width mm	Weight kg
Antenna	Set of antennas (case)	0,01 - 3000 MHz	550	170	420	6,7
Antenna	Horn antenna	0,5 - 2,8 GHz	416	240	550	3,8
Antenna	Yagi antenna	46 - 860 MHz	1050	580	250	8
Antenna	LogPer antenna	230 MHz - 2,3 GHz	650	82	790	1,6
Antenna	Parabolic antenna	1700 - 2100 MHz	1000	600	510	8,3
Measurement device	Power meter	0,2 - 4000 MHz	270	200	300	5
Measurement device	Signal generator	0,005 - 6000 MHz	430	190	350	20
Measurement device	Real time analyser	9 kHz - 14 GHz	460	270	550	28

Category	Equipment Type	Frequency Range	Length mm	Height mm	Width mm	Weight kg
Measurement device	Spectrum analyser	20 Hz - 8 GHz	470	180	520	15
Antenna accessories	tripod		200	1200	200	13
Communication	Network		200	50	150	0,5
IT-technology	Laptop		350	20	250	3,3
Communication	Walkie-talkie	150 MHz	50	200	20	0,3
Measurement accessories	Set of freq. filter	1 – 300 MHz	200	100	300	1
Measurement accessories	Digital camera		100	20	50	0,2
Measurement accessories	Field glasses		200	100	200	0,9
Measurement accessories	Magnetic compass		50	20	50	0,2
Protective equipment	Analyser	1 – 1000 MHz	30	200	30	0,4
Protective equipment	Personal protective equipment		200	200	300	0,5
Personal equipment	Baggage		300	400	200	5
Others	Toolbox		400	250	250	8
Others			100	100	100	0,5
Others						

It can be seen, that it is important to consider type of equipment that are beyond obvious devices, like antennas and measurement receivers. All kind of accessories and even personal equipment needs to be considered. The table 1 just gives enough examples to express the idea of a structured overview of equipment. As a matter of fact, a complete table can easily be made up of 200 to 300 data sets.

4 ANTENNAS FOR MOBILE SPECTRUM MONITORING UNITS

4.1 THE REQUIREMENT FOR ANTENNAS ARRANGEMENT

Antennas, used for mobile spectrum monitoring units, vary according to the frequency and nature of measurements; also, antennas should be adapted to the traffic conditions and installation requirements.

The main requirements on antennas and antenna arrangements in the mobile spectrum monitoring units are:

- antennas should be small;
- directional antennas should be arranged in a way to be easily steerable from inside of the vehicle towards the direction of reception either by hand or by electric motor;
- arrangement of antenna should ensure elimination or decreasing of the influence of vehicle roof and hull on radio signal reception and should decrease the influence of any obstacle on radio wave reception;
- position of antenna should ensure that no damages of antenna while on move and at the transportation will happen;
- it is an advantage to be able to mount the available antennas to a mast system to improve the sensitivity.

4.2 MONITORING AND MEASURING ANTENNAS FOR MOBILE SPECTRUM MONITORING UNITS

For clarification purposes administrations differ between monitoring antennas and measuring antennas. Monitoring antennas are non-calibrated antennas, whereas measuring antennas are considered to be calibrated to provide a fixed uncertainty.

The following antennas are typically used in the mobile spectrum monitoring units:

- in HF band:
 - active omnidirectional antenna STA10A;
 - active broadband rod antenna HE010;
 - active rod antenna PMM RA01;
 - loop antenna HFH2-Z2;
- in VHF/UHF bands:
 - rod-antennas (monopoles), i.e. GP 500 (600, 750) etc.;
 - broadband omnidirectional antenna HK033;
 - LogPer antennas AD22D, AD22C, VUSLP9111, LP-80-1000, LP-1000-3000;
 - active omnidirectional antennas HE309, HE314;
 - omnidirectional antennas HF214, HF902, 737003, LE NDA100, NDA300, LE NDA800;
 - dipole antenna HE302;
 - LogPer broadband antenna HL040;
 - LogPer omnidirectional broadband antenna HE500;
 - K50734, K705723, K751161, 705564 antennas;
- in SHF/EHF bands:
 - horn antennas VT320SGAH 15(20, 25 etc.);
 - biconical omnidirectional broadband antennas XP02V (2 - 18 GHz).

In some mobile spectrum monitoring units the direction finding antennas (for example, ADD071, dual-polarised VHF/UHF model 643, 647D antennas etc.) also can be used as monitoring and measurement antennas.

Omnidirectional antennas can be installed on the roof of a vehicle to search and detect transmitter emission.

Collapsible antennas are used to be set up on the ground near the stationing vehicle.

Directional antennas can be used to improve directivity, signal/noise ratio or to increase the gain and thereby to reduce interference in field-strength measurements. Small directional antennas can be mounted on the holder on the vehicle roof. Mechanical construction of the antenna supports (masts), fixed into or onto the vehicle, has an important role as it can bear heavy load. To steer the directional antenna orientation towards the direction of reception, an operator should be able to check the orientation of the antenna easily. For automatic measurements the position information should be available for remote control. A rotor, which can be controlled by the process controller, is recommended.

Omnidirectional monitoring antennas can be arranged on the vehicle roof immediately (Figure 3) or within a box on the roof (Figure 4) or on the mast as well.



Figure 3: Active omnidirectional monitoring antenna arranged on the vehicle roof (Ukraine)



a)



b)

Figure 4: Monitoring antennas arranged in box on the vehicle roof (Hungary)

To monitor the GSM900/1800/1900/UMTS/LTE cellular base stations, wireless broadband transmitters IEEE 802.11 (a, b, ac, g, n), TETRA transmitters the special antennas are used. Such antennas can be mounted on the vehicles roofs (Figure 5, Figure 6) or on the antenna mast (Figure 7) as well.



Figure 5: Special antennas for coverage measurement of GSM/UMTS/LTE cellular networks (Montenegro)

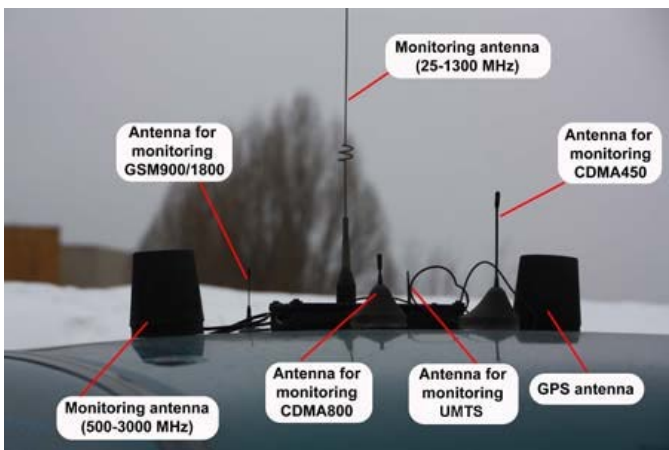

a) GSM900/1800//UMTS/CDMA450/CDMA800 (In Ukraine)

b) GSM900/1800/1900/UMTS/LTE (In Serbia)

Figure 6: Special antennas to monitor the base station transmitters of cellular networks



Figure 7: Special antennas for monitoring the wireless broadband IEEE 802.11 transmitters (Serbia)

Measuring antennas are fixed directly on the roof of a vehicle or/and on the arm support (on the holder) on the vehicle roof. In case a measuring antenna is fixed on the vehicles roof, mobile spectrum monitoring unit crew can perform the work when the vehicle is in the stationary mode or while on the move as well. The manufacturer should take due care for elimination or essential reduction of the impact of the vehicle roof on measurement results. Figure 8 shows the measuring antennas mounted on the arm support (on the holder) on the roof of the vehicle.

To perform the field strength measurements in accordance with Recommendations ITU-R SM.378 [5] it is desirable that the measuring antennas be located at a height of 10 m above the ground. Therefore, in the most mobile spectrum monitoring units, equipped with antenna mast, a possibility to adjust measuring antenna on the top of the mast is generally provided. The monitoring antennas can be arranged on in-built antenna mast or on antenna mast, mounted on the back side of the vehicle too.



Figure 8: Measuring antenna, mounted on arm support on the roof of the vehicle

4.3 DIRECTION FINDING ANTENNAS FOR MOBILE SPECTRUM MONITORING UNITS

In practice the direction finding of radio emission sources can be carried out by the direction finder with special direction finding antenna or by highly directional antenna with receiver or spectrum analyser.

In most cases in direction finding systems, equipped with digital direction finding processor, the following direction finding antennas are used:

- in HF band:
 - ADD119;
- in VHF/UHF bands:
 - ADD070, ADD150, ADD190, ADD197, model 643; (20 MHz - 3 GHz), 647D (20 MHz - 8.5 GHz)
- in UHF band:
 - ADD195, ADD071;
- in UHF/SHF bands:
 - ADD075.

Direction finding antennas can be fixed in box on the pedestal on the passenger car roof or on the arm support (Figure 8, Figure 9) or on the top of the mast (Figure 10). Direction finding antennas can be disguised as luggage on the car roof, and antennas with lower sensitivity can even be completely integrated into the roof so as not to be recognised. Usually, the impact of vehicle roof structure on bearing measurement is corrected by software (by manufacturer).



Figure 9: DF antenna, fixed on the roof of a vehicle (Bulgaria)

If antenna mast is used, in some cases the direction finding antenna can be mounted both on vehicle roof (in transport and in operating modes) or on the top of the mast (in operating mode only).



Figure 10: DF and monitoring antennas fixed on the top of the mast (Hungary)

In Ukraine some specialised mobile spectrum monitoring units use the rotating antenna system LE NDA 1600 for frequency the bands from 3 to 40 GHz. Figure 11a shows the total view of antenna system, located in a plastic radom. Figure 11b illustrates the scheme of an antenna system with dish antennas rotator. It consists of two rotating parabolic dish antennas and two antenna feeds: for the frequency band from 3 to 18 GHz (lower antenna dish) and for the frequency band from 18 to 40 GHz (upper antenna dish). As antenna feeds the quadrupole ultra wideband antenna horns are used. This antenna system provides the spectrum monitoring and direction finding under the fixed azimuthal position and in rotation mode. The measurement can be done in the stationary mode or while on the move as well.



a) Rotated antenna system into radom

b) Antenna system scheme with dish antennas rotator

Figure 11: Rotated DF antenna system (Ukraine)

5 ANTENNA MAST AND ROTATORS

5.1 ANTENNA MAST TYPES

Radio Monitoring Services in the CEPT countries use different types of antenna masts for the general purpose and specialised mobile spectrum monitoring units. The main applied antenna mast concepts are:

- pneumatic telescopic mast;
- mechanical telescopic mast.

Usually one antenna mast is used in the mobile spectrum monitoring units. However, in some mobile spectrum monitoring units two inboard pneumatic antenna masts with height 10 meters are used. Which antenna can be mounted to the mast depends on the mast payload capacity and the reference conditions. It usually varies from 20kg to 70kg (taking into account the rotators weight). The antenna mast should be resistant to the local environmental conditions, for example, to the wind speed of above 100 km/h [1]. The antenna mast height in mobile monitoring units is very different and varies from 4m to 10m.

The main types of pneumatic telescopic masts used are:

- YT90-6-NP MAST (height is 9m);
- YT10.5 MAST (height is 10m);
- 4KVR4 MAST (height is 4m, payload capacity is ~70kg).

The main types of mechanical telescopic mast are:

- 9KVR5 (AKAD096) (height is 10m, payload capacity is 40kg);
- 6KVL5 (height is 6m);
- 6KVL4 (height is 9m);
- 9KLV6 (height is 9m);
- 8KVL5/E (height are 8m and 10m, payload capacity is 20kg);
- 4KVL4 (height is 4,5m, payload capacity is 25kg);
- 8KVL5/E (height is 10m, payload capacity is 20kg);
- 10KVL6 (height is 10m, payload capacity is 25kg);
- telescopic crank mast 9KVL6/E (height is 10m).

Antenna mast design should allow for installation of two monitoring and/or measuring antennas simultaneously. In the mobile spectrum monitoring unit with a direction finder, an antenna mast should allow for installation of monitoring or measuring antenna or DF antenna separately.

5.2 POSITION OF THE ANTENNA MAST

The position of the antenna mast depends on its engineering design and size of the vehicle. In different mobile spectrum monitoring units an antenna mast is arranged inboard or externally on the rear part (on the back side) of the vehicle. Each of these positions has advantages and disadvantages.

In the most mobile spectrum monitoring units, used by Radio Monitoring Services in the CEPT countries, antenna mast generally is arranged inboard, in the vehicle rear module. The inboard antenna mast position provides its protection from any damage. Figure 12 illustrates the inboard antenna with two measuring antennas, installed on top of the antenna mast. In Figure 13 the pneumatic build-in antenna mast system accommodation in the vehicle rear module is displayed. The mast can be seen behind the grey antenna pole.



Figure 12: Inboard antenna mast with two directive antennas

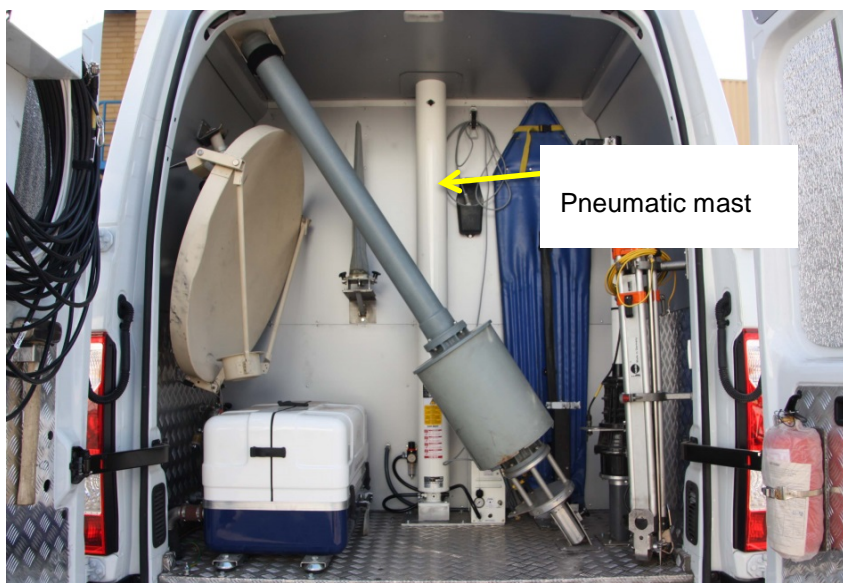

Figure 13: Pneumatic Build-in antenna mast system (Bulgaria)

In the second case, in externally accommodation on the back side of the vehicle, antenna mast can be mounted whenever the measurement with antenna mast is required and dismantled whenever there is no need for it. However, for access to the trunk the mast needs to be moved away. Another disadvantage is that it is necessary to strengthen the vehicle hull.

Figure 14 shows the mechanical antenna masts, arranged on the back side of the vehicle.



a) In transport mode



b) Mast, rotated for access to the trunk

Figure 14: Mechanical antenna mast, arranged on the back side of the vehicle (Serbia)

Figure 15 shows the arrangement of two inboard antenna masts in different vehicle modules in general purpose mobile spectrum monitoring units in Cyprus.

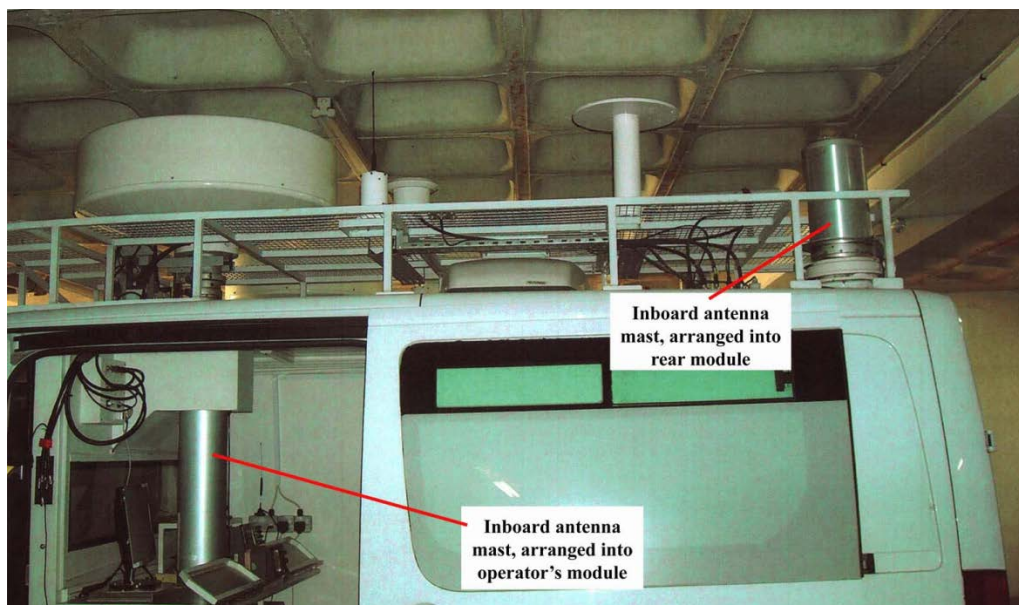

Figure 15: Arrangement of two inboard antenna masts into the vehicle modules (Cyprus)

5.3 CONTROL AND INDICATION OF ANTENNA MAST OPERATION, MOVEMENT AND POSITIONING

Control of antenna mast operation, movement and positioning can be carried out mechanically or electronically.

In the first case the hoisting engine with crank is used.

If the mechanical telescopic mast is used, control of antenna mast raising up or sinking is carried out by steel wire driven with electric winch.

When pneumatic telescopic mast is used, control and indication of antenna mast operation, movement and positioning are carried out electronically with specialised antenna rotation control and indication unit. In some cases mechanical movement with crank is possible in case of emergency.

5.4 ANTENNA FEEDER AND SUPPLY CABLE FIXING

Taking into account that directional antennas, mounted on the top of antenna mast, have to change their azimuth direction and rotate into azimuthal plane, antenna feeder and rotator supply cable should not be rigidly fixed on the antenna mast. Thus antennas are usually connected either by a direct and free cable (Figure 16a) or by a gyrated (coiled) cable (Figure 16b) around the antenna mast.



a) direct cable (Bulgaria)



b) coiled cable (Ukraine)

Figure 16: Antenna feeder and supply cable fixing

The advantage of the direct cable is that it provides less attenuation in comparison to the approach with the coiled cable. This is especially important in higher frequency ranges.

The advantage of the coiled cable is the more easy and flexible handling in comparison to the other approach. In lower position the cable will be in a cable box on the vehicle roof. If the mast is raised or lowered, the cable will always be in a well position.

Figure 17 shows the antenna feeder and rotator supply cable coiled around the antenna mast in stowed position. To prevent any damage of antenna feeder and rotator supply cable jacks it is desirable to connect them via the adapter connector.



Figure 17: Coiled antenna feeder and rotator supply cable (Montenegro)

5.5 ANTENNA AZIMUTH POLARISATION AND ELEVATION

Rotators for azimuth, elevation and polarisation planes may be operated and controlled electrically. In this case the rotating mechanism (rotator) is usually installed on the top of the mast. The rotating mechanism may consist of azimuth rotator (i.e. G2800 type) and elevation rotator (i.e. G550). In some mobile spectrum monitoring units the azimuth-elevation combination rotator G5500 is used. In general a rotating mechanism gives the possibility to rotate 360° in azimuth and 90° or 180° in elevation and to change the polarisation plane when applicable.

Some rotating mechanisms consist of azimuth rotator and polarisation plane rotator only.

The mobile spectrum monitoring unit's operator should be able to check orientation and elevation of the directional antenna easily and orientation and elevation of the antenna should be displayed in the vehicle.

To prevent any damage to the vehicle and measuring equipment from the lighting stroke, the rotator on the top of the mast should be mounted on a non-conducting antenna rod with a height of about 1 meter.

5.6 VIDEO SURVEILLANCE

In the most mobile spectrum monitoring units no video surveillance to determine the antenna position is used, although some exceptions are given. In Serbia in the vehicles with an antenna mast mounted on back, a roof camera for antenna observation is used. In Czech Republic and Latvia antenna surveillance is possible through the sunroof in some vehicles.

5.7 POSSIBILITY TO INSTALL ADDITIONAL ANTENNAS

Most mobile spectrum monitoring units are equipped with several general purpose (broadband) and specialised (narrowband) antennas. Depending on the antenna mast type, its design can provide a possibility for installation of two antennas together on the mast. Most rotators on the antenna mast provide the installation of two directional antennas (i.e. Yagi and LogPer antennas) simultaneously. However, due to the design the antennas will point in opposite directions each from other (Figure 12, Figure 16a).

Moreover, design of some antenna masts allows mounting a large DF-antenna on the vehicle roof or on antenna mast (Figure 18). The following picture shows a solution to mount and unmount it without too much effort for the staff, since the antenna turns on a metal arm. To support this construction and the movement a pneumatic spring is used.

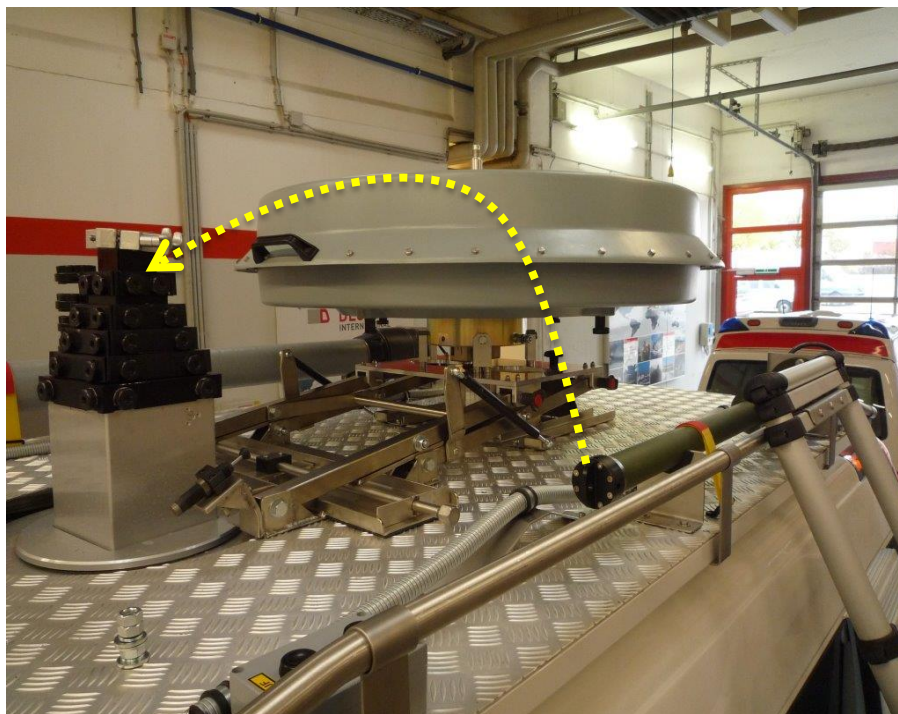

a) On arm support on the vehicle roof (before lifting)



b) On the antenna mast (after lifting)

Figure 18: Different ways of additional DF antenna mounting (Austria)

The following pictures show another possibility to install additional antennas. In the upper part of the picture a direction finder antenna is mounted on the mast. In the lower part of the picture the direction finder antenna is mounted on the roof of the vehicle and the mast can be used for another antenna setup.



Figure 19: Universal setup: DF/monitoring/measurement antenna on a mast with a possibility to replace with any other measurement antenna (Lithuania)

5.8 LEVELLING SYSTEM OF THE MAST

In order to perform field strength measurements in accordance with Recommendations ITU-R SM.378 [5] antennas has to be located at a height of 10 m above the ground. In Figure 20 are shown two mobile spectrum monitoring units with possibility of mast's verticality correction. In Figure 20 a) the levelling is automatic and managed through pneumatic suspensions that allow for a correction up to 5°, the mast movement is hydraulic and its rotation can be both manual or electric.

In Figure 20 b) the levelling is automatic and managed through a mobile plate (Figure 21a)), and allow for a correction up to 7° in both X and Y directions, the mast movement is mechanic. In both vehicles the change of polarisation can be done remotely electrically through transducers.

In both figures the red and yellow lines indicate the vehicle is parked in a hilly uneven terrain (yellow line) and the mast (red line) is almost perfectly upright.

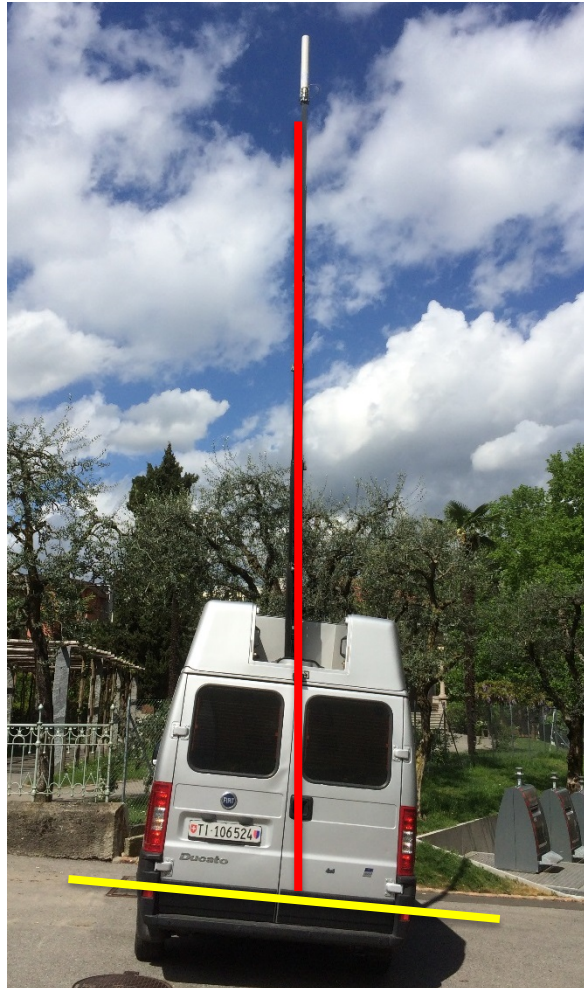

a) Van with pneumatic regulated suspension

b) Van with correction by mobile plate

Figure 20: Measuring antennas, arranged on build-in antenna mast (Switzerland)

Figure 21 a) shows the electronic levelling system and inner coiling of cables. This mast allows for simultaneous operation of two antennas. Figure 21 b) shows the control display of the levelling system.

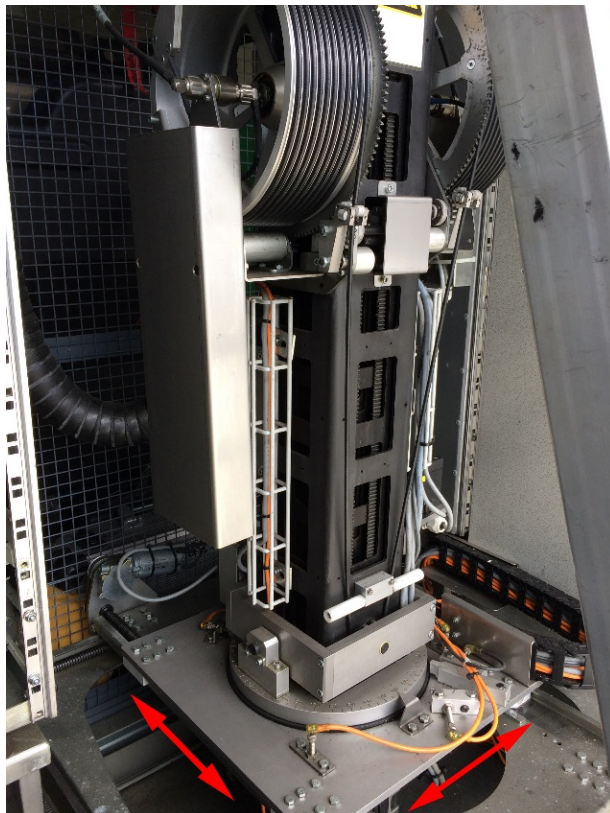

a) Mast auto levelling system and cables arrangement



b) Mast auto levelling system control

Figure 21: Monitoring and DF vehicle arrangement

Another way to provide the vehicle stabilisation and levelling can be seen in the following picture.



Figure 22: Permanent hydraulic jacking system for vehicle stabilisation (Slovenia)

When carrying out the monitoring works in stationary mode with a lifting antenna mast under severe weather events, i.e. at strong wind or on mountain roads, some adjustable jacks can be used. In Slovenia permanent hydraulic jacking system is used (upper Figure). This hydraulic jacking system has 4 jacking supports; two in the front (shown in the upper Figure 22) and two in the back of the vehicle. All four jacking supports are automatically controlled and work independent from each other to reach to an evenly levelled and lifted vehicle.

In other countries electric tire jacks or manual jacks are used.

6 MEASURING AND MONITORING EQUIPMENT

The monitoring, measuring and direction finding equipment set depends on mobile monitoring unit concept, vehicle type and assigned tasks.

As a rule, general purpose mobile spectrum monitoring units are equipped with universal monitoring and/or measuring devices in accordance with assigned tasks and frequency band operation, particularly:

- monitoring and measurement receivers;
- spectrum analysers;
- signal analysers;
- specialised devices;
- DF equipment.
- Complete system (all in one) for DF, monitoring and measurements.

In general purpose mobile spectrum monitoring units in CEPT countries the following monitoring and measuring receivers are used:

- monitoring receivers ESMB, EM550;
- measuring receivers R3000, ESMC, ESMD, EB500;
- test receivers ESPI7, ESPI3, ESVN30, ESM-20 RadMan, ESU;
- portable measuring receivers EB200, PR100;
- RF sensors (i.e. RFEye Node etc.).

The following spectrum analysers are used in general purpose mobile spectrum monitoring units:

- spectrum analysers FSP-40, FSU-8, FSQ-26, FSQ-40, FSV-7, NRA-6000 RX, MS27211, MS8911B, Site Master, FT9100, RSA6000;
- portable (handheld) spectrum analysers FSH6, FSH8, SA2500, IDA2, Field Fox, S332D, 3106, E4404, Sefram 7866 HDT2, NBM-550, SRM-3000, SAF;
- Real Time spectrum analyser RSA306; FSVR
- MDS spectrum analyser;
- USB-spectrum analyser RSA306 etc.

The following devices are used in specialised mobile spectrum monitoring units:

- universal radio network analysers TSMW, TSMQ;
- TV analysers ETL, AMA310;
- portable broadcast test receiver (analyser) MSK200;
- modulation analysers Audemat FM-MC4, Audemat FM, Deva broadcast DB3000, FM-analyser RBT;
- TV receivers Prolink-4, HD RANGER 2;
- TV test receivers EFA, 4T2;
- portable SAT/TV/FM Test receiver EFL100 PRODIG;
- TV signal Analyser Televes H60 Advance;
- FM broadcast receiver STR-DE215;
- 4x Qualipoc terminals Audemat Aztec FM100;
- measuring system SwissQual Diversity Benchmark;
- different kits for monitoring and measurement of radio transmitter emission parameters GSM900/GSM1800/UMTS/LTE telecommunication technologies;
- different network scanners with measuring phones etc.

The following direction finder receivers and antenna control units are used in general purpose mobile spectrum monitoring units with direction finder:

- DF receiver DDF190 with DF Unit EBD190 (or EBD195) and antenna control unit GB127;

- DF receivers DDF255;
- direction finders DDF550, DDF05E;
- monitoring and DF receivers Comms Audit SPECTRA 200 and Comms Audit SPECTRA 500;
- spectrum monitoring, measurement and DF system TCI 739.

Also mobile spectrum monitoring units may be equipped with other different equipment, particularly, with signal generators (for example, HP8648C etc.) and power meters (for example, NRT).

The allocation of monitoring, measurement and DF equipment are highly dependent on the size and vehicle concept.

In most cases the equipment is fixed in the racks. Shock absorption is installed. Figure 23 shows the arrangement of measuring, monitoring and additional devices in standard racks. These racks are installed in a Mercedes Sprinter Van.



Figure 23: Arrangement of measuring, monitoring and additional devices in standard racks (Germany)

In smaller vehicles, like passenger cars, the monitoring equipment is generally arranged in the car boot (Figure 24 a)). In some cases monitoring equipment can be arranged in the car interior (Figure 24 b)).

In larger vehicles, such as vans, the monitoring, measuring and DF equipment is arranged in the back part of the car, where the operator seat is located.



a) In the boot (Hungary)

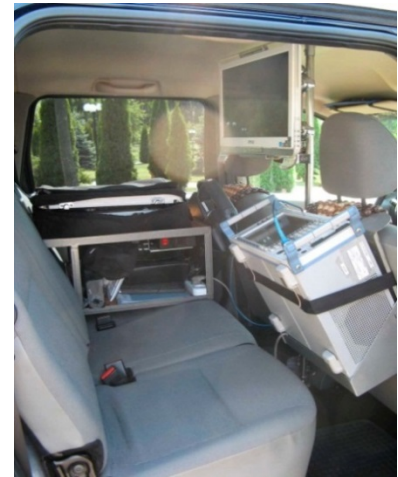

b) In the car interior (Ukraine)

Figure 24: Monitoring and measuring equipment accommodation in smaller vehicles

Figure 25 shows the block-diagram of RF and IT network in mobile spectrum monitoring units in Hungary.

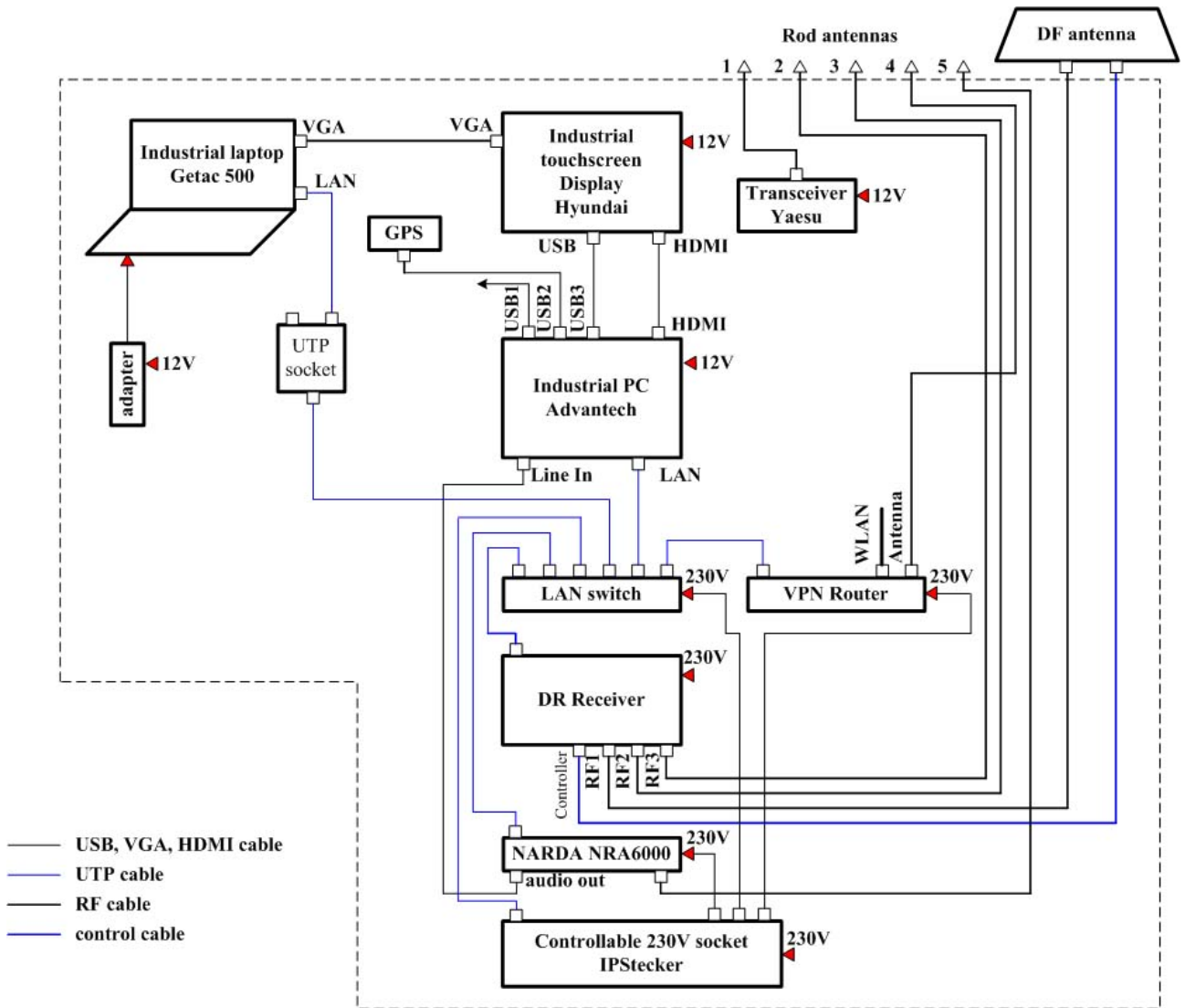

Figure 25: Block-diagram of RF and IT network in mobile spectrum monitoring units (Hungary)

7 POWER SUPPLY

The power supply system in mobile spectrum monitoring units depends on the vehicle concept. Information on the supplied power of some type of measurement equipment is given in Spectrum Monitoring Handbook [2]. In practice the mobile spectrum monitoring units mostly need power supply of more than 500VA. The power supply system should not cause any interference for monitoring, measurement and DF equipment in the mobile monitoring unit.

The power supply is provided by batteries or from generators coupled to the engine with inverters when the vehicle is moving. It depends on the capacity of the batteries if and for how long the equipment can be used without a turned on engine.

In Figure 26 the block-diagram of one vehicle power supply system in Hungary is shown.

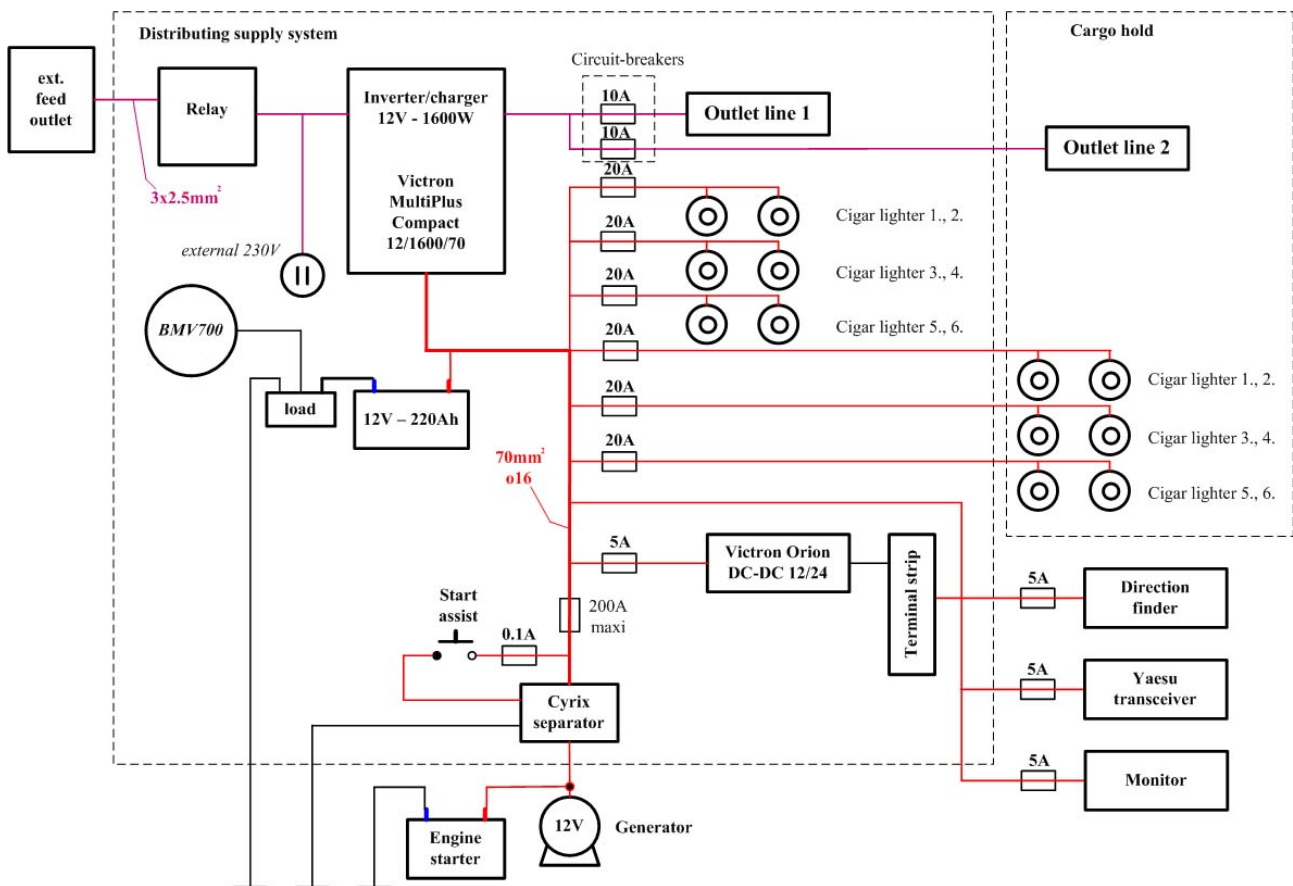

Figure 26: Block-diagram of power supply system in the vehicle (Hungary)

Battery capacity should provide monitoring and measurement equipment operation during full working day and depends on the assigned tasks. In practice the total capacity of the batteries in mobile spectrum monitoring units in CEPT countries is from 110Ah till 240Ah. Battery chargers are used for 24V, 50A. As a rule, AGM (Absorbent Glass Mat) or 240Ah gel type batteries are mainly used.

The output power of inverter with a sinusoidal voltage 24VDC/230VAC is not less than 2kW. In most cases the inverters with power from 1kW till 2.5kW are used. Taking into account the importance of human safety, as a rule, Diesel generators and isolating transformer (2KVA) are used. The Diesel generator output power is greater or equal to 3,5kW; 230V.

Inboard Diesel generator is arranged in the vehicle rear module and operates in stationary mode.

Portable Diesel generator can be transported in the rear module and it is placed outside of the vehicle at the operation. Figure 27a shows the inboard Diesel engine, located in rear compartment of the vehicle, Figure 27b - Diesel engine cooling radiator, located on the vehicle roof. No grounding is used in most vehicles. In Germany the grounding meet the applicable standards to electricity (metal rod).

Mains supply has the goods on independent power source of mobile spectrum monitoring units and it is always preferable to take it at the operation in stationary mode whenever possible. This should be done in order to keep the auxiliary lighting and air-conditioning plant in good running order, or, of course, to recharge the service batteries and the built-in instrument batteries through their respective charging devices.



a) Inboard Diesel engine



b) Diesel engine cooling radiator, located on the vehicle roof

Figure 27: Inboard Diesel engine system of power supply system (Ukraine)

Figure 28 shows the total view of power supply system control unit together with an emergency off switch. On the left an inverter can be seen.



Figure 28: Power supply system control unit (Serbia)

8 REQUIREMENTS FOR ADDITIONAL AND SPECIALISED EQUIPMENT

The mobile spectrum monitoring unit should be equipped with additional and specialised equipment to carry out the monitoring works in any weather and environmental conditions.

8.1 INFORMATION TECHNOLOGIES USED FOR THE MOBILE SPECTRUM MONITORING UNITS

The mobile spectrum monitoring units frequently have to operate far away from office and in stationary mode. In this situation it is sometimes necessary to clarify the assigned tasks or to transmit the monitoring data to the office, to the fixed monitoring station or to exchange the data of direction finders in the composite system and the local direction finder of the vehicle to improve the direction finding accuracy. Thus, a reliable communication between operators of the mobile spectrum monitoring unit, of the fixed monitoring stations and of the central office is required. Therefore GSM / UMTS / LTE / Wi-Fi telecommunication technologies are generally used in mobile spectrum monitoring units for external communication. LAN is used to exchange the data between internal equipment in the mobile spectrum monitoring units.

In Latvia self-made monitoring software has been used to automatically detect presence of a signal, store results and visualise results in most convenient way for engineer to make decision on signal's origin and make further actions in real time. In the mobile spectrum monitoring unit the staff has the possibility to work on-line and off-line with access to a central database to get actual license information and to store monitoring results.

8.2 NAVIGATION EQUIPMENT AND FREQUENCY NORMAL

Modern vehicles are often equipped with a GPS system to aid navigation. Alternatively this feature may be provided by smart phones.

The majority mobile spectrum monitoring units have additional GPS systems which provide 10MHz reference frequencies, precise time information and positioning data (longitude, latitude and altitude), which may be further processed by PCs or instruments measuring field strength and other parameters along a route. The GPS antenna is usually located on the vehicle roof. However, the antenna may also be mounted in a DF antenna radome.

Especially when performing measurements in cellular radio service like LTE, precise timing for triggering the given signal is essential. In combination with a function / arbitrary waveform generator the 10 MHz reference signal provided by the GPS-System can be used to create highly precise waveforms for triggering.

Portable GPS receivers may be used for the registration and documentation of measurements in the last mile and on-site or outside of the vehicle.

GPS can only provide information about position but no direction information. Both speed and direction information can only be obtained when the GPS system moves. To overcome this problem, mobile spectrum monitoring units can be equipped with an electronic compass. Also some DF systems have their own GPS system and electronic compass.

If precise location information is required, even when GPS signals are not available due to shadowing, so called dead reckoning systems based on inertial navigation may be used. However, such systems are not required for the usual spectrum monitoring measurements.

For example, in Slovenia, mobile spectrum monitoring units are equipped with two GNSS antennas and splitter to divide signal for additional equipment. One antenna is located at the front and other is at the back of the vehicle roof. One GPS antenna is a part of the own vehicle navigational system.

In Lithuania the original car navigation system, a ship heading sensor, is used. This is a combination of GPS and a Compass which provides the Heading information (the angle between North and the direction in which the vehicle is facing).

8.3 ADDITIONAL EQUIPMENT

Additional equipment, such as tripods, additional antennas, cable coils etc., can be located in vehicle rear compartment (Figure 13) or into special box, for example, located on the vehicle roof (Figure 29).



Figure 29: Additional equipment in box, located on the vehicles roof (Slovenia)

9 EMC IN THE VEHICLE

Vehicle electrical and electronic system, including air conditioner and climate control system, generating sets etc. can create radio interference for measurement, monitoring and DF equipment. The requirement for radio interference (in terms of electromagnetic compatibility) referring to the vehicles in EU are set forth in the Regulation (EC) No 661/2009 [6].

In most CEPT countries no measurements of EMC in the vehicles are carried out a priori. Interferences from the vehicles equipment may be eliminated by switching off the interference source if it is not related to the measurement equipment itself.

However, in some countries, like in Czech Republic all vehicles are checked and inspected before putting into operation and are measured in shielded chamber to find out and eliminate all interferences originated from car installation.

In Hungary EMC measurements are made by a supplier before handover and in case of fault finding, repair made with ferrite rings or the defective parts are replaced.

In Latvia before taking mobile spectrum monitoring unit into operation, detailed EMC measurements are made, and information about vehicle's generated interferences (emissions) are saved in self-made spectrum monitoring software database. In the field operation the information from the database is taken to automatically exclude interferences (emissions) during spectrum monitoring measurements.

In Germany testing is performed to ensure the EMC on the vehicles components in accordance with the following documents:

Installation guidelines of the car manufacturer;

- DIN VDE 0100 Erection of power installations with nominal voltages up to 1000V;
- DIN VDE 0100-717 Power installations in transportable units;
- DIN VDE 0800, 2 communications technology;
- DIN VDE 0879 Radio disturbance characteristics.

However, being in line with the installation guideline does not ensure that no interferences occur.

10 DESIGN FEATURES OF MOBILE SPECTRUM MONITORING UNITS

10.1 ONBOARD ARRANGEMENT OF WORKING SPACE

Arrangement of a vehicle interior depends on the vehicle size, mobile spectrum monitoring unit concept and executing tasks.

In smaller vehicles, like passenger cars or SUVs usually three seats can be used by the staff:

- driver's seat;
- one passenger seat next to the driver seat (co-driver seat);
- one operator's seat in the back of the car.

In passenger cars an operator has a small table installed on the back seat or on the back side of passenger seat, on which working computer (laptop), keyboard, mouse/trackball, display unit are located (Figure 31). The laptop can be mounted in the front right seat. Operator seat is oriented in the direction of driving. Measuring equipment, UPS system, switches and additional equipment, like cables and auxiliary tools, are stored in the car boot. The following picture (Figure 30) shows a setup with a measurement laptop very close to the driver's seat. To ensure the safety in traffic it is not allowed to operate this equipment while driving.



Figure 30: A driver's compartment view (Hungary)



Figure 31: Work station arrangement in smaller car (Ukraine)

Usually the crew of mobile spectrum monitoring units consists of two persons.

The first reason is that in some countries this requirement is ordered by Industrial Safety Rules.

Second reason is due to facts, that in most situations two persons are needed to fulfil the monitoring tasks. For example one person can perform the monitoring tasks while the other person is moving the vehicle. In other situations one person is at the place of interference and talks to the customer and the other person can perform the measurements in the vehicle. In both constellations one person has to have a deep technical knowledge about monitoring. Depending on the technical education of the second person they also can discuss about technical manners.

Larger vehicles, such as vans or heavy-duty utility vans, generally 2 or 3 seats are installed in driver compartment. In addition these vehicles do have some extra seats in the back of the car. However, in accordance with the mandatory national recommendations and rules for the use of motor vehicles in some countries the transportation of people is permitted only in the front of the car (in the drive compartment and on passenger seats). In this case, the number of mobile spectrum monitoring unit crew is limited to three persons.

In the most mobile spectrum monitoring units the work station in operator module is fitted out with table (working desk), computer, keyboard, mouse/trackball and display. An operator's work station in a larger vehicle, like a Van, is displayed on Figure 32, Figure 33 and Figure 34. A chair for an operator is securely fastened to the floor and is positioned ergonomically for easy operations. A mobile spectrum monitoring unit crew can perform the monitoring tasks even when the car is moving therefore the seat has to be equipped with a safety seat belt. In this case the operator is either face in direction of driving or in the opposite direction.

Monitoring, measurement and DF equipment can be mounted in trunk or into a rack and are allocated in close to the operator module. IT and power supply components can be allocated under the operators table. In larger vehicles, such as in vans, a second monitor can be allocated in the drive compartment for a fast access and "on-the-run" measurements.



Figure 32: Operator's work station in a vehicle with an integrated wall between driver and operator (Ukraine)

In these larger vehicles the monitoring, measuring and DF equipment can also be mounted in the back of the vehicle or close to the operator. Figure 33, Figure 34 show a working space possibility arranged in vehicles. In most of these vehicles the equipment is mounted in standard 19 inch racks (Figure 33), in special non-type boxes or suitably shaped fasteners to secure the electronics and to offer some protection against shock and vibration. The antenna mast can be arranged in the vehicle rear module. In general the operator module can be accessed through the sliding door, in other cases it also can be accessed from the driver's cabin like shown in Figure 35. The mast, additional monitoring and measuring antennas, cables, auxiliary tools, and miscellaneous items are allocated in the rear module. Air conditioner is arranged in the rear module too.

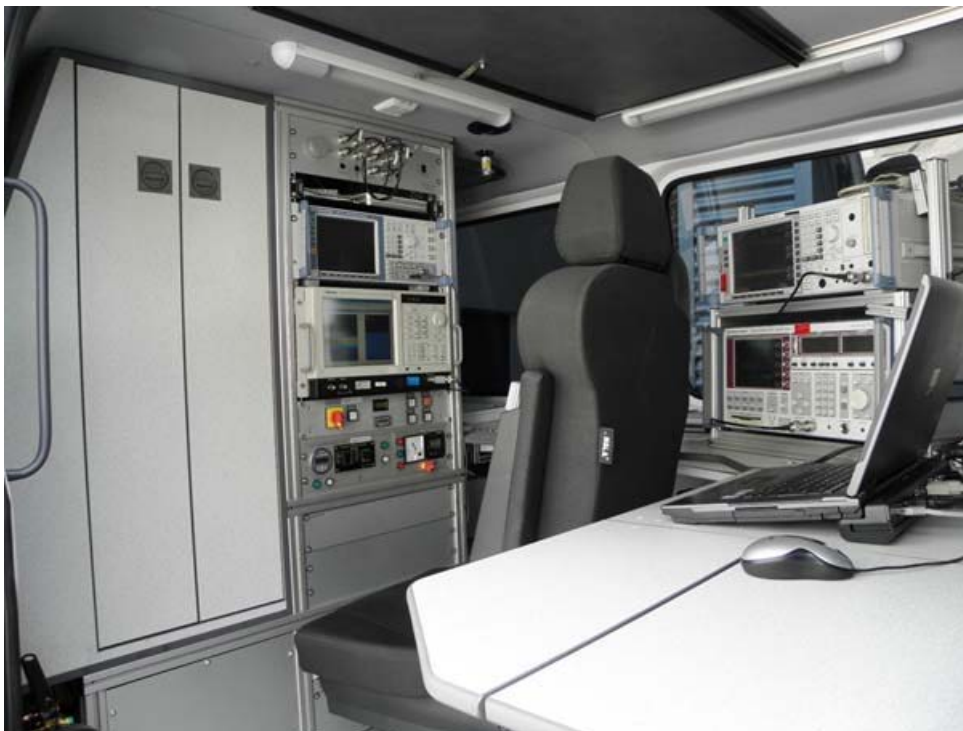

Figure 33: Operator work station in a van (Germany)



Figure 34: Operator working space with two rotatable seats (Latvia)

The total number of seats may be five in larger vehicles, such as vans (3 in the front and 2 operator seats in the back). In some countries the operator seat is oriented in the opposite direction of driving and cannot be used while moving, in other countries there is possibility to use such operator seats while the car is moving. In the last case the operator seats have to be equipped with the seat belts. In some mobile monitoring units (e.g. in Germany) even two seats can be rotated by 360° (the co-driver seat and the operator seat in the back). Since the seat in the back is equipped with seat belts the operator can use this seat while the car is moving. However, in this case the seat must face the driving direction or be set to the opposite. In Figure 34 setup with two rotatable seats (including seat belts) can be seen.

Some mobile spectrum monitoring units are equipped with an extra monitor with remote connection, so an operator in larger vehicles, such as vans, can work also from the co-driver seat. Additionally, in some mobile spectrum monitoring units an operator module can be darkened completely with blackout curtains.

Figure 35 and Figure 36 show a block diagram of a construction arrangement of the car interior including the work station.

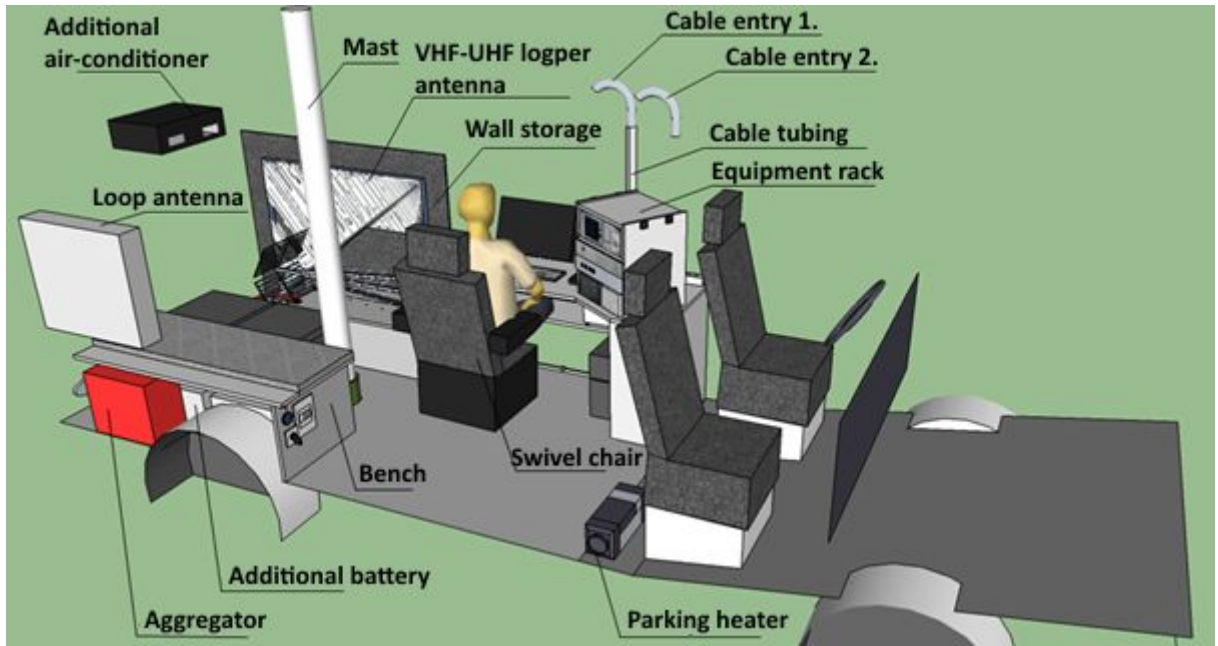

Figure 35: Block diagram of construction arrangement of the car interior (Hungary)

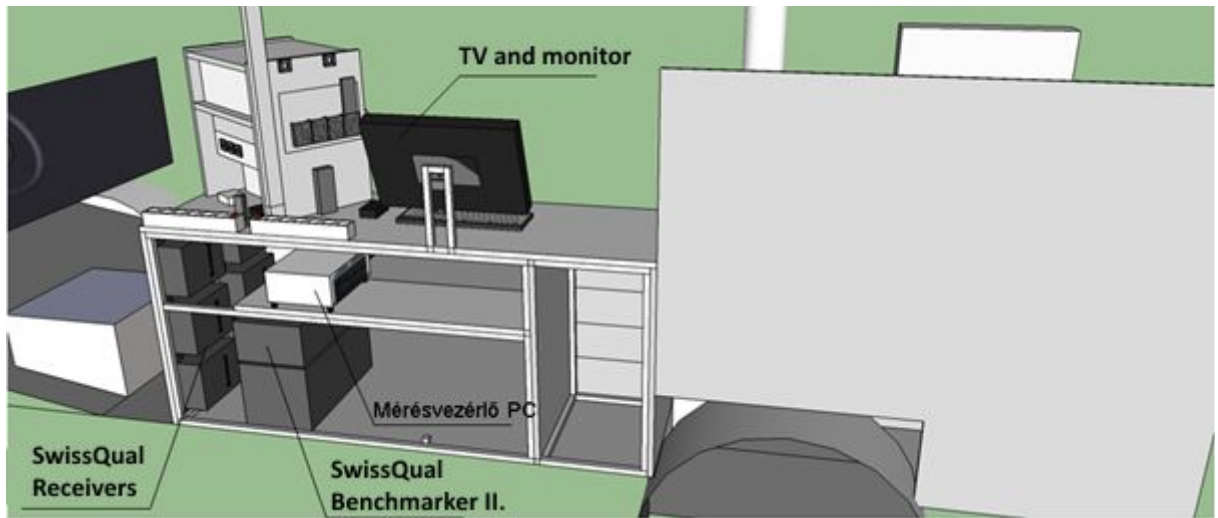

Figure 36: Block diagram of the equipment packing (Hungary)

The block diagram of general purpose mobile spectrum monitoring unit MKMS2014 design (Montenegro) is shown in Figure 37.



Figure 37: Block diagram of general purpose mobile monitoring unit (Montenegro)

10.2 AIR CONDITIONING

In general, the conditioning inside the vehicles depends on their size and type, as well on the typical weather conditions in the country. In smaller vehicles, for example in passenger cars original climate-control and conditioning system of the vehicle is used. This can be done, since these cars are of that size, that there is only a limited space to install heat producing equipment and between the driver's compartment and the back part of the vehicle are no integrated walls.

This situation is different in larger vehicles such as vans. Here in the back part of the car a lot of heat producing equipment is installed. If, in addition an integrated wall separates the driving compartment and the operators area in the back of the vehicle a ventilation concept is necessary. In some cases a ventilation tube system is sufficient; in other cases in the operator module self-independent extra cooling/heating system is used.

10.3 VEHICLES DESIGN FEATURES

If mobile spectrum monitoring units are of a certain height, such as heavy-duty utility vans, minibuses, buses or light trucks, a ladder should be used to fulfil work on the vehicles roof. This can either be a portable and extendable version that is stored in the trunk of the car or a ladder that is fixed mounted on back side of the vehicle (Figure 38).



Figure 38: Portable ladder, mounted on back side of the vehicle (Montenegro)

11 OTHER ISSUES

11.1 REGISTRATION OF THE VEHICLES, RULE-BOOKS AND INSTRUCTION MANUALS

In the majority of CEPT countries the vehicles are registered as working vehicles. Since the total weight is less than 3.5 tons the driving license of class B (or D1 category in Switzerland) is required to drive the monitoring unit.

Rule-books and instruction manuals are developed for all mobile spectrum monitoring units. Manufacturer's operational and service manuals are used for all measuring, monitoring and DF equipment. Documents for operation of the mobile spectrum monitoring units are the same as the as those for the fixed monitoring stations.

In some countries on the vehicles, used in mobile spectrum monitoring units, company name is printed on back side and/or on side faces of vehicle or by temporary magnetic cards.

For the safety reasons in some countries light beacon/traffic signs or the warning LED lights are fitted all around the vehicle.

According to European Union technical rules (2007/46/EC) for vehicle safety COC (Certificate of Conformity) in some countries mobile spectrum monitoring vehicles have to go through a certification if additional seats are installed which are designed for use while driving.



Figure 39: Marking with the enterprise name (Ukraine)



Figure 40: Marking with the enterprise name (Montenegro)

11.2 THE MOBILE SPECTRUM MONITORING UNITS CHALLENGE

The functional and technical possibilities of mobile spectrum monitoring units should comply with telecommunications development level and provide the monitoring and measuring of present day telecommunication technologies and new technologies as well.

The key features of new telecommunication technologies development trends are:

- output power reduction of transmitters;
- the expansion of higher frequency bands;
- widening of signal bandwidth;
- usage of the frequency reuse and introduction the cell-like structures of telecommunication networks.

In the most cases fixed monitoring stations cannot carry out the monitoring and measuring of the most new telecommunication technologies, because of their fixed location and limited service areas.

In contrast to that mobile spectrum monitoring units can fulfil the spectrum monitoring tasks within and beyond the fixed service area by enabling to approach the emitters, for example, with low power level, high transmission directivity antenna etc.

Mobile spectrum monitoring units are an important tool for spectrum monitoring of present and advanced telecommunication technologies.

The general trends of mobile spectrum monitoring units' development may be determined as follows:

- to improve the technical networking among the vehicles and among fixed stations, in order to get to a fast and reliable exchange any kind of data.
- to improve the measurement accuracy of radio signal and radio emission parameters by using higher-end measurement equipment;
- to improve the bearing and geolocation accuracy by using higher-end direction finding equipment.

ANNEX 1: LIST OF REFERENCES

- [1] Recommendation ITU-R SM.1723-2: "Mobile spectrum monitoring unit"
- [2] Spectrum monitoring Handbook (in Edition 2011)
- [3] Radio Regulation
- [4] Recommendation ITU R SM.1537: "Automation and integration of spectrum monitoring systems with automated spectrum management"
- [5] Recommendation ITU-R SM.378: "Field-strength measurements at monitoring stations"
- [6] Regulation (EC) No 661/2009 of the European Parliament and of the Council of 13 July 2009 concerning type-approval requirements for the general safety of motor vehicles, their trailers and systems, components and separate technical units intended therefor
- [7] Directive 2007/46/EC of the European Parliament and of the Council of 5 September 2007 establishing a framework for the approval of motor vehicles and their trailers, and of systems, components and separate technical units intended for such vehicles (Framework Directive)