



ECC Report **277**

Use of SRD applications in cars in the band 5725-5875 MHz

approved 27 April 2018

0 EXECUTIVE SUMMARY

This ECC Report investigates the use of SRD applications in the band 5725-5875 MHz in cars equipped with 5.8 GHz road toll equipment, WAS/RLAN use in cars based on the 5.8 GHz SRD regulation (max. 25 mW) as well as co-channel ITS communications (5855-5875 MHz) which are all operating under the existing SRD regulations. The aim this Report is to investigate, under the existing regulations, potential problems when having all these applications implemented in the same car within close proximity to each other.

The following sharing scenarios have been studied:

- WAS/RLAN use with max. 25 mW in the band 5725-5875 MHz under the SRD regulation (ERC Recommendation 70-03 ANNEX 1: Non-specific short range devices , band 5725-5875 MHz) and road toll equipment (ERC/REC 70-03 ANNEX 5: Transport and traffic telematics (TTT)), band 5795-5815 MHz) as victim;
- Co-channel non-safety ITS use (5855-5875 MHz, as per ECC/REC/(08)01 [20]) and WAS/RLAN use with maximum 25 mW e.i.r.p. in the band 5725-5875 MHz under the SRD regulation.

Use cases for WAS/RLAN in cars include smartphone links and rear-seat entertainment, requiring only short distance links with relatively low output power (typically 20mW), but large channel bandwidths (80 MHz).

Studies on non-safety road-ITS and WAS/RLAN in cars are based on MCL calculations and existing work in ECC Report 244 [24] as well as in ETSI TR 103 319 [45].

- MCL calculations using worst-case I/N values¹ for both directions of interference showed the need for significant separation distances, which cannot be met in realistic scenarios, especially if both systems are in the same vehicle;
- Coordinated channel access between RLAN and ITS depends on the ability to mutually detect either the energy detection or the preamble of each other's devices, preamble detection is currently not applicable, since both systems use different bandwidths;
- Under the assumption that RLAN could detect safety related ITS preambles, timing issues have been studied in ETSI TR 103 319. Based on the protection requirements assumed for safety related ITS, it was found that interference before ITS detection and interference after ITS detection needed to be distinguished. The mitigation methods Detect&Vacate and Detect&Mitigate in ETSI TR 103 319 differ in post-detection-mitigation, where Detect&Vacate eliminates post-detection interference into safety related ITS. Pre-detection interference can be reduced by a modest amount of extra inter-packet spacing in the order of a few hundred microseconds. The protection requirements of non-safety ITS may differ from safety related ITS;
- An automobile manufacturer that is in control of the RLAN and ITS deployment in its vehicles may be able to find alternative ways of enabling co-existence between RLAN and non-safety ITS.

Studies of road tolling (TTT) and WAS/RLAN in cars are based on MCL calculations, lab and field measurements as well as existing work in ECC Report 244 and in ETSI TR 103 319:

- MCL calculations worst-case I/N values (Footnote 1) for both directions of interference showed the need for significant separation distances;
- Experiments show that RLAN detects the TTT signal and will reduce or stop its transmissions at some point when approaching the toll stations and this may enable the TTT toll transactions to be completed. However, it appears that the range of detection is smaller than the worst-case separation distance taken from the MCL calculations. Thus, the effect of RLAN transmissions in cars outside the RLAN receiver detection range may cause interference to a TTT RSU during its communication with other cars;
- Within the detection range of a TTT signal the RLAN reduces or stops transmitting with the consequential throughput loss as long as the vehicle is in the vicinity of the detectable TTT transmissions;

¹ MCL calculations are based on ECC Report 244.

- Lab and field measurements in Spain and Germany show a slight increase in the duration of TTT transaction times when RLAN is active on adjacent channels;
- In studies looking at higher power RLAN use, mitigation methods have been suggested and assessed in ETSI TR 103 319.

The effect of aggregate RLAN deployments in a number of cars and the associated interference environment has not been considered. Experiments have been conducted with only a single vehicle.

TABLE OF CONTENTS

0	Executive summary	2
1	Introduction	8
2	TECHNICAL SPECIFICATIONS OF THE SYSTEMS CONSIDERED IN THE STUDIES.....	9
2.1	RLAN in the 5 GHz band	9
2.1.1	Basic characteristics for WAS/RLAN in the band 5725-5875 MHz under SRD regulation	9
2.1.2	RLAN antenna pattern	10
2.1.3	RLAN deployment and density of active devices	11
2.2	Road-ITS Technical Characteristics	11
2.2.1	ITS antenna pattern	13
2.3	Road Tolling (TTT).....	15
2.3.1	Road tolling technical parameters	15
2.3.2	Antennas	17
2.3.3	Road tolling Protocol.....	17
2.4	Other SRD	19
3	EXISTING REGULATIONS AND PREVIOUS STUDIES RELEVANT TO THE WORK ITEM.....	20
3.1	Overview on Regulations in the Band 5725-5875 MHz.....	20
3.2	Radio local area networks (RLANS).....	21
3.3	Intelligent Transport Systems (ITS).....	22
3.4	Road Tolling (TTT).....	23
3.5	Other SRD	23
4	STUDIES.....	24
4.1	Coexistence of WAS/RLAN in the band 5725-5875 MHz under SRD regulation and ITS	24
4.1.1	Description of scenarios.....	24
4.1.1.1	Scenario 1: In-car RLAN with external ITS antenna	24
4.1.1.2	Scenario 2: In-car RLAN with in-car ITS Antenna	24
4.1.2	Results of MCL calculations for interference from RLAN into non- safety ITS in the band 5855-5875 MHz	25
4.1.3	Results of MCL calculations for interference from ITS into RLANs in the band 5855-5875 MHz.....	26
4.1.4	Summary - Analysis	27
4.1.5	Mitigation techniques to enable coexistence of RLAN and ITS.....	28
4.1.5.1	Generic requirements related to Energy Detection for the coexistence between RLAN and ITS	29
4.1.5.2	Clear Channel Assessment in IEEE 802.11 - requirements for the coexistence between RLAN and ITS.....	30
4.1.5.3	Applicability of CCA to ITS	31
4.1.6	Summary.....	32
4.2	Coexistence of WAS/RLAN in the band 5725-5875 MHz under SRD regulation and Road Tolling (TTT)	33
4.2.1	Description of the scenario: RLAN on-board a vehicle.....	33
4.2.1.1	Scenario 1	33
4.2.1.2	Scenario 2	33
4.2.2	Results of MCL calculations for interference from RLAN into road tolling RSUs	34
4.2.3	MCL Calculations for interference from RLAN into road tolling OBUs	34
4.2.4	Results of MCL calculations for interference from road tolling into RLAN.....	35
4.2.5	Results of MCL calculations on the detection of TTT by RLAN	36
4.2.6	Results of lab measurements including road tolling and RLAN.....	37
4.2.6.1	Equipment	37

4.2.6.2	Measurement setup of the lab tests	37
4.2.6.3	Measurement results of the lab tests	38
4.2.7	Results of field measurements including road tolling and RLAN.....	38
4.2.7.1	Measurement setup of the Spanish Motorway tests	38
4.2.7.2	Measurement results of the Spanish motorway field tests.....	40
4.2.7.3	Measurement setup of the German motorway field tests.....	41
4.2.7.4	Measurement results of the German motorway field tests.....	41
4.2.8	Summary - Analysis	44
4.2.8.1	Summary of MCL calculations.....	44
4.2.8.2	Summary of lab and field measurements.....	45
4.3	Mitigation techniques to enable coexistence of RLAN and road tolling (TTT)	46
4.3.1	Energy Detection requirements for the coexistence between RLAN and road tolling.....	46
4.3.2	Transmission from the road tolling applications of predefined signals (beacons)	49
4.3.3	Geolocation database requirements for the coexistence between RLAN and road tolling	49
4.3.4	Summary.....	49
5	CONCLUSIONS.....	51
	ANNEX 1: Propagation Model	53
	ANNEX 2: List of References.....	54

LIST OF ABBREVIATIONS

Abbreviation	Explanation
AP	Access Point
ASECAP	European Association of Operators of Toll Road Infrastructures
AS/ASS	Active Sensors
BDA2G	Broadband Direct Air To Ground
BFWA	Broadband Fixed Wireless Access
BPSK	Binary Phase-shift Keying
CCA	Clear Channel Assessment
CENELEC	European Committee for Electrotechnical Standardization
CEPT	European Conference of Postal and Telecommunications Administrations
C-ITS	Cooperative Intelligent Transport system
C/N	Carrier to noise ratio
CS	Carrier Sensing
CSMA/CA	Carrier Sense Multiple Access with Collision Avoidance
DA2GC	Direct Air-to-Ground Communications
DCC	Decentralised Congestion Control
DFS	Dynamic Frequency Selection
DSRC	Dedicated Short Range Communication (as of CEN EN 12253)
EC	European Commission
ECC	Electronic Communications Committee
ED	Energy Detection
EDCA	Enhanced Distributed Channel Access
EETS	European Electronic Toll Service
e.i.r.p	Equivalent isotropic radiated power
ETSI	European Telecommunications Standards Institute
FSS	Fixed Satellite Service
HEN	Harmonised European Standard
IEEE	Institute of Electrical and Electronics Engineers
I/N	Interference to noise ratio
ISM	Industrial, scientific and medical
ITS	Intelligent Transport System
ITU	International Telecommunication Union

Abbreviation	Explanation
LAA	License Assisted Access
LBT	Listen Before Talk
LTE	Long Term Evolution
MBR	Maritime Broadband Radio
MCL	Minimum Coupling Loss
MCS	Modulation Coding Scheme
NF	Noise Floor
OBU	On-Board Unit
OFDM	Orthogonal Frequency Division Multiplex
P2MP	Point-To-Multi-Point communication
P2P	Point-To-Point
POD	Probability of Detection
PSD	Power Spectral Density
QAM	Quadrature Amplitude Modulation
QPSK	Quadrature Phase-shift Keying
RLAN	Radio Local Area Network
RSU	Road-Side Unit
Rx	Receiver
RTTT	Road Transport and Traffic Telematics
SRD	Short Range Device
SRD/MG	Short Range Device / Maintenance Group
TC BRAN	Technical Committee Broadband Radio Access Networks
TLPR	Tank Level Probing Radar
TPC	Transmitter Power Control
TTT	Transport and Traffic Telematics
Tx	Transmitter
UE	User Equipment
WAS	Wireless Access System
WG FM	Working Group Frequency Management of the ECC
WG SE	Working Group Spectrum Engineering of the ECC
WIA	Wireless Industrial Applications

1 INTRODUCTION

This Report deals with the co-existence analysis of WAS/RLAN in the band 5725-5875 MHz under SRD regulation operated in cars and ITS as well as road tolling (TTT) systems. All these systems operate in the band 5725-5875 MHz at the same or adjacent frequencies.

The systems referred to in this Report are as follows:

RLAN: Radio Local Area Networks belong to the class of Wireless Access Systems (WAS), which provide end-user radio connections to core networks [52]. Radio Local Area Networks (RLANs) serve geographically limited areas, and they are predominantly used inside buildings, but not limited to indoor use. This Report specifically studies WAS/RLAN use in cars in the band 5725-5875 MHz that operate under the generic SRD regulations. Use cases for WAS/RLAN in cars include:

- Interconnection with smartphones (e.g. Android Auto, Apple CarPlay and MirrorLink);
- High speed internet access for smartphones and tablets, where a RLAN access point with cellular backhaul provides internet access to devices inside the vehicle;
- Cable replacement for rear-seat entertainment systems. Integral components such as embedded control units are usually not connected over wireless links.

Short Range Devices (SRD): ERC Recommendation 70-03 ANNEX 1: Non-specific short range devices [26] contain the band 5725-5875 MHz (Band j) in the 5 GHz range. Maximum radiated peak power is limited to 25 mW e.i.r.p. No duty cycle limit or maximum PSD/MHz levels are applied in this band for generic SRD use. The EN 300 440 [29] applies to this use. This band is also designated for industrial, scientific and medical (ISM) applications as defined in ITU Radio Regulations.

Intelligent Transport Systems (ITS): ITS are defined in Directive 2010/40/EU [11] as “advanced applications which [...] aim to provide innovative services relating to different modes of transport and traffic management and enable various users to be better informed and make safer, more coordinated and ‘smarter’ use of transport networks. ITS integrate telecommunications, electronics and information technologies with transport engineering in order to plan, design, operate, maintain and manage transport systems.”

Road tolling (TTT): In this Report, Road tolling is intended as systems for electronic toll collection that involve communication between road tolling equipment on-board vehicles and fixed road-side infrastructure equipment in the frequency band 5795-5815 MHz.

2 TECHNICAL SPECIFICATIONS OF THE SYSTEMS CONSIDERED IN THE STUDIES

2.1 RLAN IN THE 5 GHZ BAND

RLAN systems based on IEEE 802.11 [49] are considered in this Report under SRD regulation, which use the frequency band 5725 MHz to 5875 MHz with a maximum output power of 14 dBm (25 mW) e.i.r.p.

Systems based on IEEE 802.11ac use up to 80 MHz wide channels. 20 MHz or 40 MHz channels are supported by IEEE 802.11n devices which are typically used today. It is not possible to use a 160 MHz channel within the frequency band 5725 MHz to 5875 MHz.

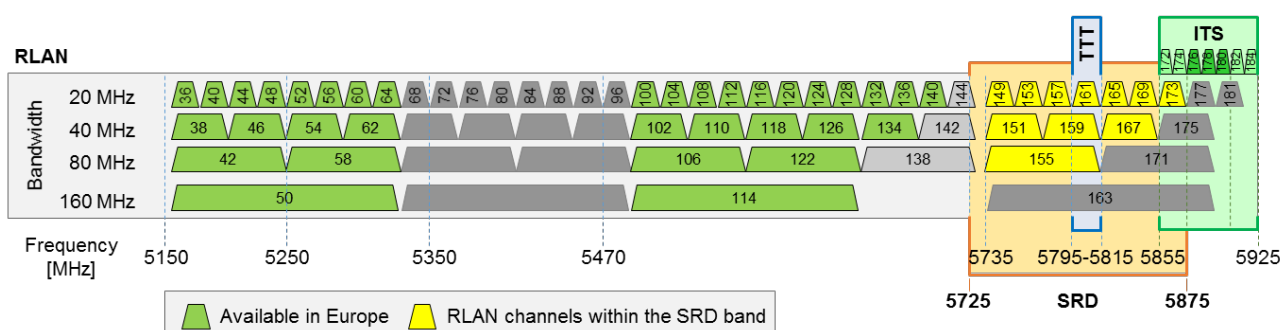

Figure 1: Overview of 5 GHz Channels for IEEE 802.11

Channelisation, considered in this Report, only refers to IEEE 802.11ac. However, Licensed Assisted Access LTE (LAA-LTE) Release 13 [42] uses the same minimum channel bandwidth of 20 MHz and the same channelisation considered by IEEE 802.11ac [49]. EU spectrum regulations do not mandate any particular channelisation or minimum bandwidth.

2.1.1 Basic characteristics for WAS/RLAN in the band 5725-5875 MHz under SRD regulation

Table 1: Basic transmitter characteristics for WAS/RLAN in the band 5725-5875 MHz under SRD regulation

System parameter	Value
Maximum Transmit Power (e.i.r.p. - dBm)	14
Bandwidth (MHz)	20 / 40 / 80
Maximum Transmit Power Density (e.i.r.p. - dBm/MHz)	10 / 7 / 4
Typical AP Antenna Type	Omni (azimuth)
AP Antenna directivity gain (dBi)	0

Figure 2 below provides the spectrum mask for RLAN as function of the nominal channel bandwidth, typically 20, 40 or 80 MHz.

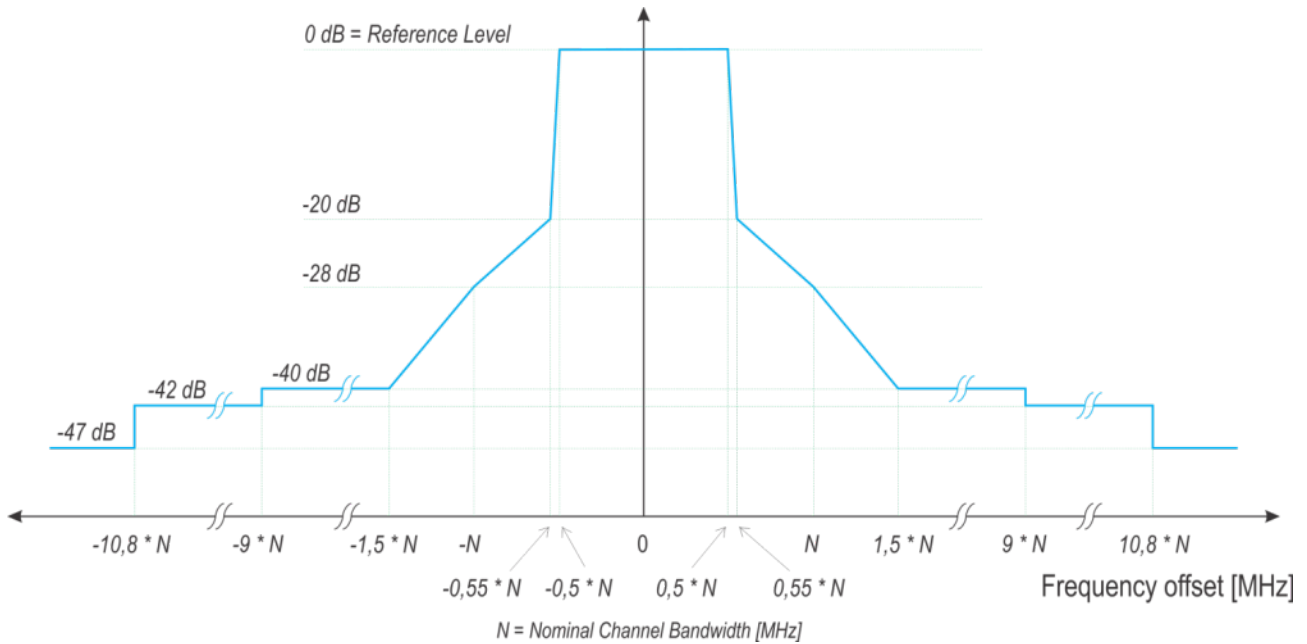

Figure 2: Spectrum mask for RLAN

Table 2 provides RLAN receiver parameters for the purpose of compatibility studies.

Table 2: Basic receiver characteristics for WAS/RLAN in the band 5725-5875 MHz under SRD regulation

System parameter	Value		
Bandwidth (MHz)	20	40	80
kTB (dBm / bandwidth)	-101	-98	-95
Typical Noise figure (dB)	4		
Noise Power (dBm / bandwidth)	-97	-94	-91
Typical Sensitivity for MCS0, BPSK (½ coding rate) (dBm)	-92	-89	-86
C/N for MCS0, BPSK (½ coding rate) (dB)	5		
I/N (dB) (note 1)	-6		
C/I (dB)	11 for I/N -6 dB; 5 for I/N 0 dB		
Maximum antenna gain at the RLAN user device (dBi)	See Table 3		

Note 1: As per ITU-R Recommendation M.1739 [53], the I/N ratio at the WAS/RLAN receiver should not exceed -6 dB, assuring that degradation to a WAS/RLAN receiver’s sensitivity will not exceed approximately 1.0 dB. Whilst it is designed to address interference from multiple sources, this criterion is also considered in this Report for single-entry analysis.

2.1.2 RLAN antenna pattern

The characteristics in Table 3 are representative of an average antenna for all User Equipment within a population of RLAN devices, including home and office equipment. For RLAN in cars, the devices could include mobile or portable ones, and also devices that are closer integrated into the vehicle (e.g. cable replacement for rear-seat entertainment).

The following antenna characteristic in Table 3 was considered in ECC Report 244 [24] for conventional RLAN usage. It might apply to RLAN on-board vehicles. For fixed installations of RLAN in vehicles, new types of antenna patterns optimised for usage inside a vehicle might be considered in future studies.

Table 3: RLAN User Equipment antenna (mobile/portable device)

#	Type	Gain (dBi)	Antenna height above ground (m)
1	Omnidirectional antenna	1.3	1 to1.5

NOTE: This value is the average value obtained from a survey on RLAN UE antennas. For simplicity, this antenna is assumed to be isotropic.

2.1.3 RLAN deployment and density of active devices

Deployment densities of RLAN in vehicles have not been considered in the present report. In previous reports only fixed RLAN deployments were considered, e.g. CEPT Report 57 [6], section A3.1.7. For RLAN in vehicles, field measurements [47] show that several automobile manufacturers have already deployed RLAN in cars, and there are bus operators that equip their vehicles with RLAN access points. This includes RLAN in the whole 5GHz range [including the SRD band].

The density of active devices could be estimated by considering typical traffic densities and assuming a certain percentage of cars equipped with RLAN. Typical traffic densities on highways reach up to around 25 vehicles/km/lane in stable flow [55]. In a traffic jam, densities of 100 vehicles/km/lane can be reached. Here the ratio of heavy goods vehicles as well as the overall number of available lanes has an impact. While there are statistics on the percentage of new cars, there is little information on the penetration rate of 5 GHz RLAN in new cars and the usage of these devices. Further field measurements would be needed to reliably quantify the density of active devices.

2.2 ROAD-ITS TECHNICAL CHARACTERISTICS

Table 4: System parameters of road-ITS

Parameter	Value	Comments
Frequency stability	10 ppm	According to ETSI EN 302 571 V2.1.1 (2017-02) [38].
Maximum radiated power (e.i.r.p.)	33 dBm according to the Harmonised Standard ETSI EN 302 571 V2.1.1 (2017-02)	ITS channels relevant in this Report are 5860 MHz and 5870 MHz, see Figure 3. Note: The reduction of power levels below 33 dBm (23 dBm/MHz) in the band 5855 MHz to 5875 MHz is not mandated by spectrum regulation, see ECC REC(08)01 [20], and not mandated by the Harmonised Standard ETSI EN 302 571 V2.1.1 (2017-02) [38], but only defined in the ITS-G5 access layer standard EN 302 663 V1.2.1 (2013-07) [39].
Antenna beam shape/gain	For road-side unit (RSU) and on-board unit (OBU) use antenna model ITU-R F.1336-3 [51] with parameters G_0 5 dB, k 1.2, max gain in +10 deg elevation	See Figure 4 and Equation 1. In ECC Report 101 [22] there were 2 possible antennas, one very directional and one omnidirectional ITU-R F.1336-1. However ITS systems development shows that the omnidirectional will be the dominant type and therefore only

Parameter	Value	Comments
		this should be used in these compatibility studies. There is a new version of model ITU-R F.1336-3 which should be used. Both versions 1 and 3 results in exactly the same antenna performance with these parameter settings.
Polarisation	Vertical linear	The antenna performance is not described in ETSI EN 302 571 V2.1.1 (2017-02) [38], however the vertical linear polarisation is dominant.
Modulation scheme	BPSK QPSK 16QAM 64QAM	According to ETSI EN 302 571 V2.1.1 (2017-02) and ETSI EN 302 663 V1.2.1 (2013-07). Default: QPSK 1/2 (for channels 5860 MHz and 5870 MHz).
Data rates	3/4.5 /6/9/12/18 /24/27 Mbit/s Mandatory: 3/6/12 Mbit/s	According to ETSI EN 302 571 V2.1.1 (2017-02) and ETSI EN 302 663 V1.2.1 (2013-07). Default: 6 Mbit/s using QPSK 1/2 (for channels 5860 MHz and 5870 MHz).
Channel bandwidth	10 MHz	According to ETSI EN 302 571 V2.1.1 (2017-02) and ETSI EN 302 663 V1.2.1 (2013-07)
Communication mode	Half-duplex, broadcast	Half-duplex and broadcast are believed to be adequate for most applications considered to date.
Receiver noise power	-100 dBm	Typical performance, same value is used with the RLAN technology
Receiver sensitivity	-92 dBm/MHz	Based on -82 dBm for a bandwidth of 10 MHz. ETSI EN 302 571 V2.1.1 (2017-02) specifies minimum required sensitivity.
Protection criterion	I/N=-6 dB	

The required power levels (e.i.r.p.) range from 3 dBm to 33 dBm to achieve communication distances of up to 1000 m.

To avoid channel saturation in areas with a high density of vehicles, a Decentralised Congestion Control (DCC) mechanism in ITS equipment dynamically adapts the transmit rate based on how occupied a channel currently is.

There is a mechanism in ITS radios which reduces the output power and/or transmit rate when the radios are close to 5.8 GHz TTT/DSRC road tolling stations.

Unwanted emission levels are given by to ETSI EN 302 571 V2.1.1 (2017-02) [38] for the out of band domain and ITU-R SM.329 [54] and ERC/REC 74-01 [27] for the spurious domain.

Table 5: Transmitter unwanted emission limits inside the 5 GHz ITS bands (e.i.r.p.)

Power spectral density at the carrier center f_c (dBm/MHz)	± 4.5 MHz Offset (dBm/MHz)	± 5.0 MHz Offset (dBm/MHz)	± 5.5 MHz Offset (dBm/MHz)	± 10 MHz Offset (dBm/MHz)	± 15 MHz Offset (dBm/MHz)
23	23	-3	-9	-17	-27
The limits are reduced by 10 dB for the 5870 MHz channel and by 33 dB for the 5860 MHz channel.					

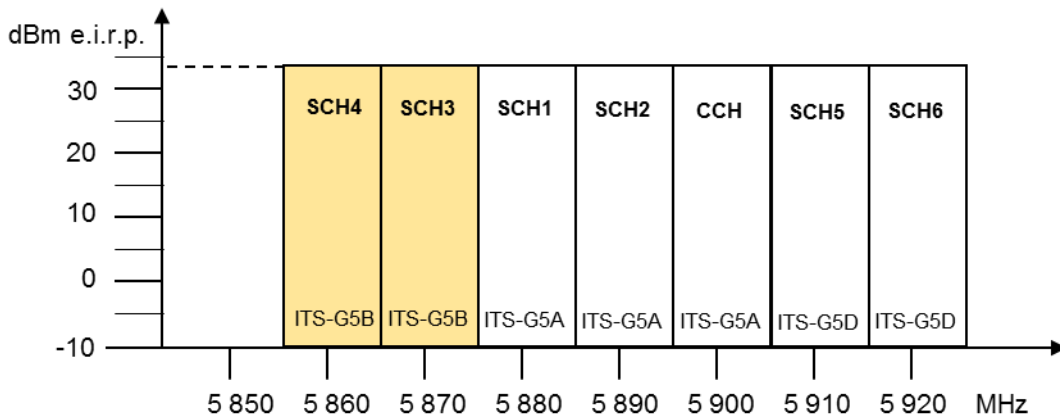

Figure 3: Maximum power limit for each ITS-G5 channel

Table 6: Minimum required receiver sensitivity according to EN 302 571 [38]

Modulation	Coding rate	Minimum sensitivity (dBm)
BPSK	1/2	-85
BPSK	3/4	-84
QPSK	1/2	-82
QPSK	3/4	-80
16-QAM	1/2	-77
16-QAM	3/4	-73
64-QAM	2/3	-69
64-QAM	3/4	-68

Note: receivers will have up to 10 dB better sensitivity

2.2.1 ITS antenna pattern

As stated in Table 4, the OBU and RSU use the Recommendation ITU-R F.1336-3 [51] antenna model with the following parameters: $G_0=5$ dB, $k=1.2$, and a maximum gain pointed at +10 degrees elevation angle. Figure 4 depicts the shape of the antenna pattern obtained with according to Recommendation ITU-R F.1336-3, compared with the G Malcolm Antenna.

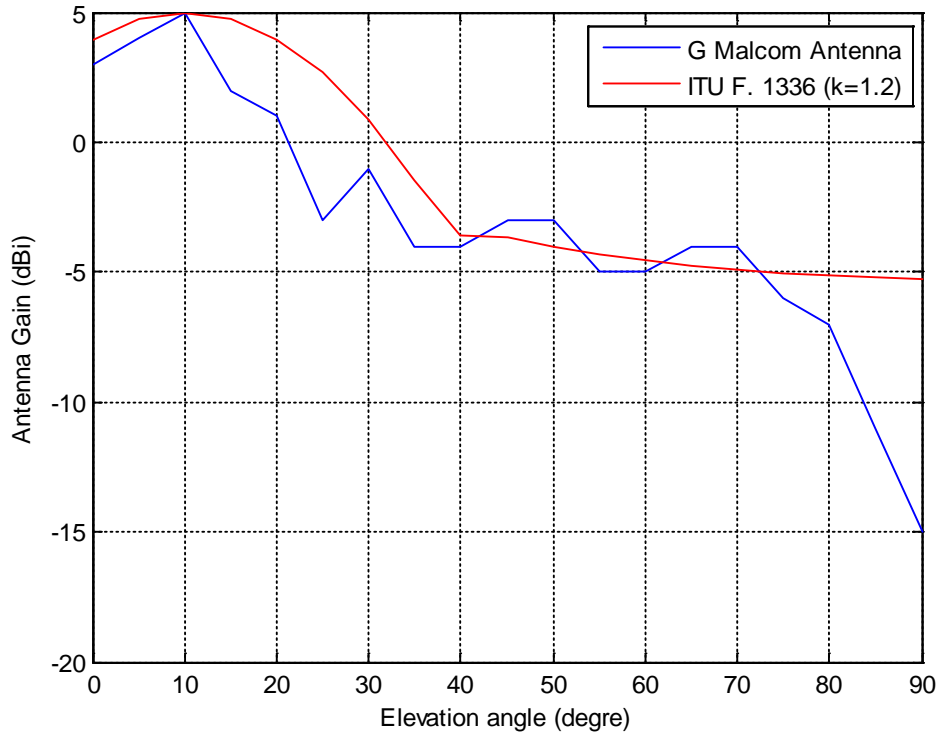

Figure 4: OBU and RSU antenna patterns of ITS

The following equations are extracted from Recommendation ITU-R F.1336-3 and used to derive the above antenna pattern, applying $G_0=5$ dB, $k=1.2$.

$$G(\theta) = \begin{cases} G_0 - 12 \left(\frac{\theta}{\theta_3} \right)^2 & \text{for } 0 \leq |\theta| < \theta_4 \\ G_0 - 12 + 10 \log(k + 1) & \text{for } \theta_4 \leq |\theta| < \theta_3 \\ G_0 - 12 + 10 \log \left[\left(\frac{|\theta|}{\theta_3} \right)^{-1.5} + k \right] & \text{for } \theta_3 \leq |\theta| \leq 90^\circ \end{cases} \quad (1a)$$

with

$$\theta_3 = 107.6 \times 10^{-0.1 G_0} \quad (1b)$$

$$\theta_4 = \theta_3 \sqrt{1 - \frac{1}{1.2} \log(k + 1)} \quad (1c)$$

where:

- $G(\theta)$: gain relative to an isotropic antenna (dBi)
- G_0 : the maximum gain in the azimuth plane (dBi)
- θ : elevation angle relative to the angle of the maximum gain (degrees) ($-90^\circ \leq \theta \leq 90^\circ$)

- θ_3 : the 3 dB beamwidth in the elevation plane (degrees)
- k: parameter which accounts for increased sidelobe levels above what would be expected for an antenna with improved sidelobe performance

Regarding coexistence studies where these systems are potential victims of interference from other systems, representative receivers have been used as follows.

In the case of ITS, the RSU is considered to point towards the ground from an elevated position whereas the OBU uses an aerial that is omnidirectional in the horizontal plane and has some directivity in the vertical plane. The most susceptible of these is the vehicular unit.

2.3 ROAD TOLLING (TTT)

The 5795-5805 MHz frequency band is identified in ERC/REC 70-03 ANNEX 5: Transport and traffic telematics (TTT) [26] with possible extension to 5815 MHz.

2.3.1 Road tolling technical parameters

The regulatory parameters (maximum power levels) for TTT are given in ERC/REC 70-03 ANNEX 5: Transport and traffic telematics (TTT) . The road tolling system parameters used in this Report are taken from ECC Report 244 [24] and ECC Report 250 [25]. These parameters are based on EN 300 674 [30][31][32] developed by ETSI and CEN EN 12253 [1] developed by CEN. It should be noted that EN 300 674 deals with both RSU and OBU and is divided in two parts. Part 1 [30] provides general characteristics and test methods, while Part 2 [31][32] contains the essential requirements under article 3.2 of the Radio Equipment Directive (2014/53/EU) [12].

Table 7: Summary of characteristics of the road tolling (TTT/DSRC) systems

	Road-Side Units	On-board units
Frequency range (MHz)	5795 and 5815	
e.i.r.p.	2 W (33 dBm) standard for $-35^\circ \leq \theta \leq 35^\circ$ 18 dBm for $\theta > 35^\circ$ 8 W (39 dBm) optional Note: Tx power of 2 W e.i.r.p. European Harmonised Standard ETSI EN 300 674. Tx power of 8 W e.i.r.p. road tolls in Italy ETSI ES 200 674-1	Maximum re-radiated sub-carrier e.i.r.p.: -24 dBm (Medium data rate) -14 dBm (High data rate)
Antenna gain	10 – 20 dB (assumed front-to-back ratio of 15 dB)	1 – 10 dB (assumed front-to-back ratio of 5 dB)
Transmitter bandwidth	1 MHz	500 kHz
Receiver bandwidth	500 kHz	1 MHz (see Note 2)
Polarisation	left circular	left circular
Receiver sensitivity (at the receiver input)	-104 dBm (BPSK)	-60 dBm
Receiver noise power (at the receiver input)	-115 dBm	
Co-channel C/N (dB)	6 for 2-PSK, 9 for 4-PSK, 12 for 8-PSK	Not defined

	Road-Side Units	On-board units
I/N (dB)	-6	

Note 1: The receiver parameters in the standard family ETSI EN 300 674 (2016) may deviate from the values in Table 7.
 Note 2: The baseband bandwidth of an OBU receiver is 1 MHz. OBUs normally use detector diodes for down conversion, therefore they are sensitive for interference not only in-band but also out-of-band.

Figure 5 depicts the road tolling frequency utilisation for 1.5 MHz sub-carrier frequency, according to the EN 300 674. The location of downlink channels from RSU to OBU and the location of uplink channels from OBU to RSU become visible.

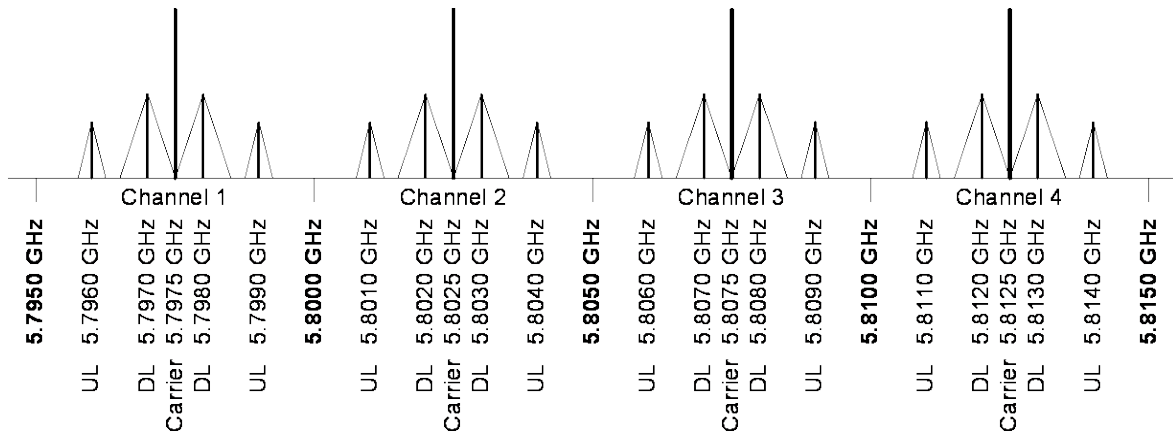

Figure 5: Road tolling systems frequency utilisation for 1.5 MHz sub-carrier frequency, according to ETSI EN 300 674

The transmit power limits of road tolling downlink, uplink and out of band emissions are depicted in Figure 6.

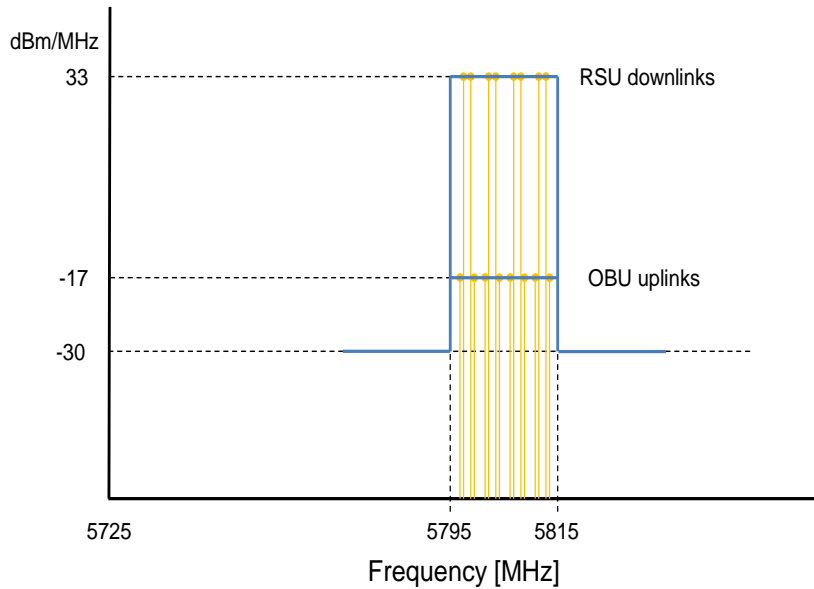

Figure 6: e.i.r.p. limits of road tolling systems

2.3.2 Antennas

The RSU Tx and Rx antennas are tilted downside by 45° for the interrogation of the on-board units. An RSU is typically installed in a height of 6 m to 7 m. A typical road toll installation is shown in Figure 7.

Table 8: Characteristics of the road tolling antennas in RSU and OBU

Antenna	Value	uplink/downlink
R _x antenna gain main lobe to communication zone, see Figure 7:		
RSU R _x antenna	13 dBi left circular (10 dBi vert. lin.)	uplink, OBU to RSU
OBU R _x antenna	8 dBi left circular (5 dBi vert. lin.)	downlink, RSU to OBU
RSU R _x / T _x Antenna sidelobe suppression in horizontal plane, see Figure 7 (Figures give the difference in gain between main lobe and horizontal direction):		
RSU R _x antenna	-15 dB	uplink, Interferer to RSU
RSU T _x antenna	-25 dB	downlink, RSU to Interferer
Antenna polarisation: Left-circular		

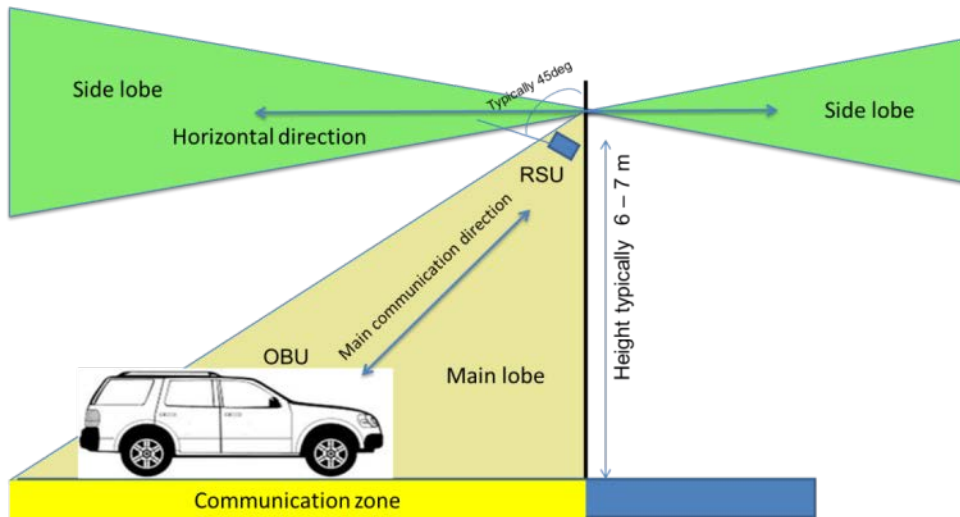

Figure 7: Antenna configuration for road tolling systems

2.3.3 Road tolling Protocol

The communication with TTT/DSRC tolling technology is always between one RSU placed on or beside the road and one OBU placed in a vehicle. The RSU acts as master and decides when the OBU shall respond, the OBU is never allowed to transmit without permission from the RSU. The OBU does not have its own signal generator; the transmission from the OBU is based on reflection and modulation on a sinus carrier sent from the RSU.

The communication protocol of the CEN DSRC tolling system is based on a packet exchange between the RSU and the OBU. In the protocol some degree of redundancy is built in by simple repetition in case a packet has to be disturbed by interference. In general the RSU sends out a general non-personalised request to all active OBUs in its range. The first OBU answering with its ID will then be processed further by

sending out a personalised request only addressing this single OBU. During this communication several packets are exchanged and at the end the transaction is closed.

In case an uplink packet (OBU to RSU) will not be received by the RSU (Interference into the RSU), the RSU will retransmit the request packet after a certain waiting time in the range of some ms. Retransmissions can be repeated several times. The transaction is defined as failed after a number of retrials, which is depending on the individual parameter settings in the RSU. It can be seen in the following that a single interference event during a transaction can only delay the transaction but will not lead to a fail of the transaction. Only when a number of interference events occur during a transaction a transaction failure might be generated.

A part of a typical transaction scheme is depicted in Figure 8. Here the transaction is not depicted for the complete time duration. The typical distribution of transaction durations is given in Figure 9. In Figure 8, an interference event occurs during a downlink (RSU and OBU) communication, thus the OBU has not been able to receive the RSU packet. It can be seen that after a waiting time the RSU repeats the Tx packet and then receives the answer from the OBU with some delay. The timing given here is only tentative and might be different for different installation and systems.

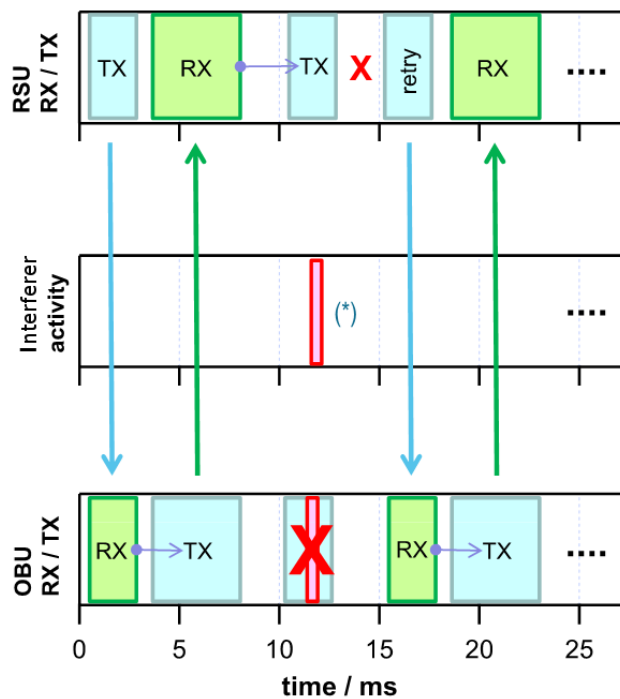

Figure 8: Part of a typical transaction scheme between RSU and OBU in CEN DSRC

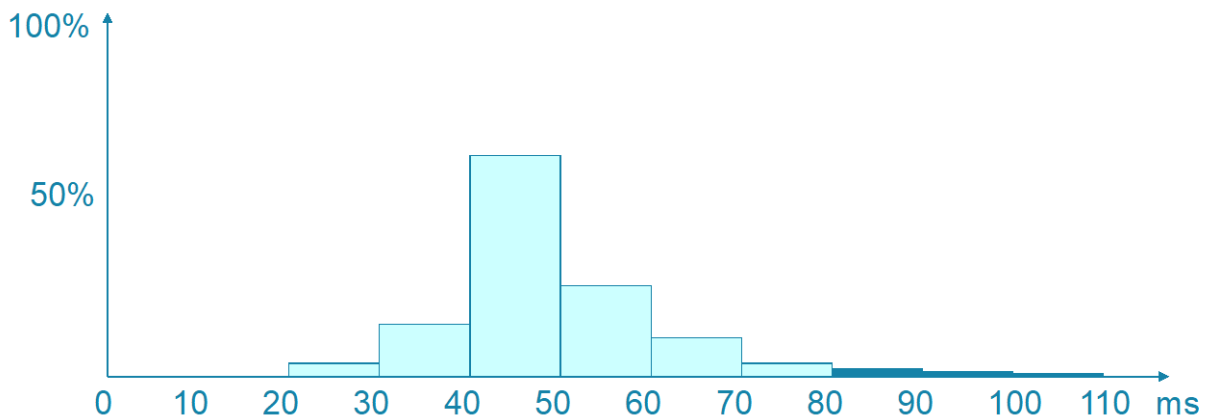

Figure 9: Histogram of a typical tolling transaction duration**2.4 OTHER SRD**

Other SRD have not been studied in the present Report.

The following SRDs could be found in road vehicles or in their vicinity:

- Retrofitted rear-view cameras with wireless links between the camera unit and the head unit;
- Motion detectors based on GHz short range radar operating at 5.8 GHz, on driveways in residential areas.

These SRDs could become relevant for WAS/RLAN use in the band 5725-5875 MHz under SRD regulation. However, there was no interest from the SRD industry and no system parameters are documented. Therefore, they are not studied in this Report.

3 EXISTING REGULATIONS AND PREVIOUS STUDIES RELEVANT TO THE WORK ITEM

3.1 OVERVIEW ON REGULATIONS IN THE BAND 5725-5875 MHz

Figure 10 below is an overview of the systems/services in the band 5725-5875 MHz.

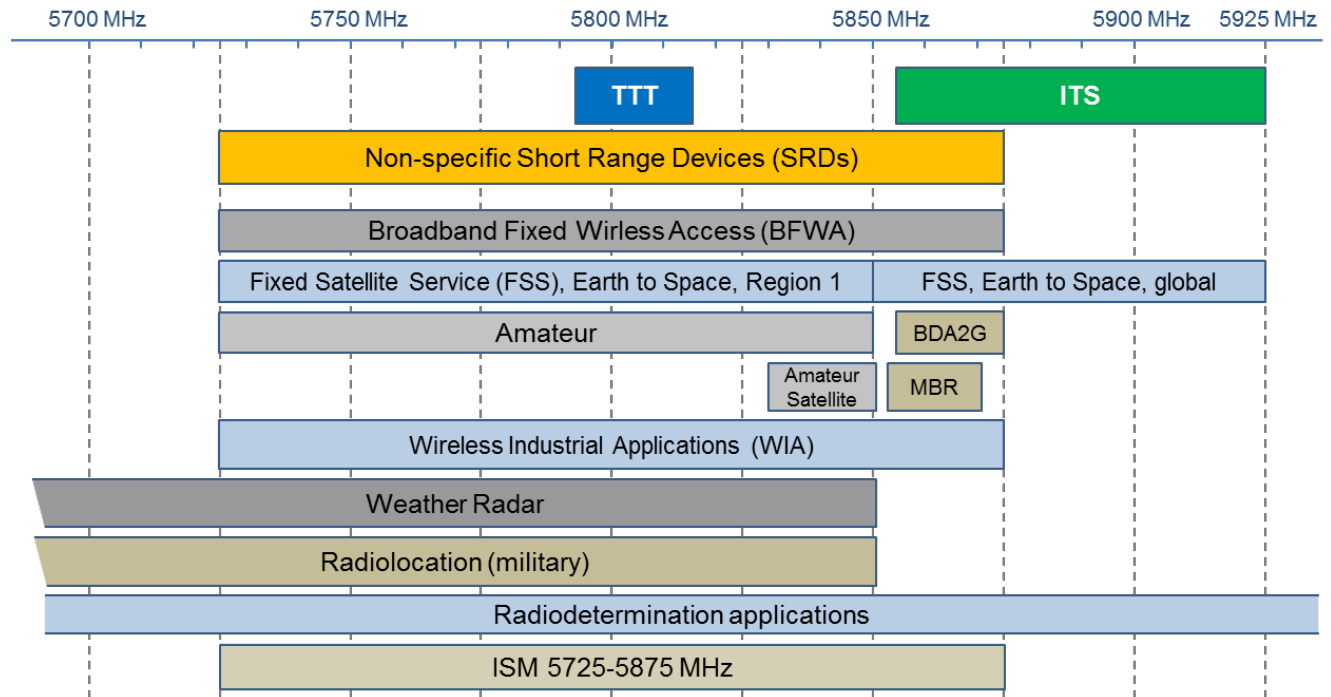

Figure 10: Overview of systems/services in the band 5725-5875 MHz

Table 9: Overview of applications in the band 5725-5875 MHz

Application	Frequency Range	ECC/ERC harmonization measure	Standard	Notes
Amateur	5650-5850 MHz		EN 301 783 [34]	
Amateur Satellite	5830-5850 MHz			
BFWA	5725-5875 MHz	ECC/REC/(06)04 [19]	EN 302 502 [37]	
Direct Air-to-Ground Communications (DA2GC)	5855-5875 MHz	ECC/DEC/(15)03 [18]		
FSS Earth Stations	5850-5925 MHz		EN 301 443 [33]	Priority for civil networks
ITS	5855-5875 MHz,	ECC/DEC/(08)01 [17]	EN 302 571	Only the part non-

Application	Frequency Range	ECC/ERC harmonization measure	Standard	Notes
	5875-5925 MHz	ECC/REC/(08)01 [20] ERC/REC 70-03 [26]	[38]	safety 5855-5875 MHz is considered here.
Industrial, scientific and medical (ISM)	5725-5875 MHz			
Maritime Broadband Radio (MBR)	5852-5872 MHz, 5880-5900 MHz	ECC/REC/(17)03 [21]	EN 303 276 [40]	
Non-specific SRD	5725-5875 MHz	ERC/REC 70-03	EN 300 440 [29]	
Radiodetermination applications	4500-7000 MHz	ERC/REC 70-03 (Annex 6)	EN 302 372 [36]	Within the band 4500-7000 MHz for TLPR application
Radiolocation (military)	5250-5850 MHz			
TTT	5795-5815 MHz	ERC/REC 70-03 (Annex 5)	EN 300 674 [30][31][32]	Within the band 5795-5805 MHz. TTT in the band 5805-5815 MHz on a national basis
Weather Radar	5250-5850 MHz			Ground based and airborne
WIA	5725-5875 MHz	ERC/REC 70-03 (Annex 2)		Not considered to be used outside factories

Note: see the ECA table [28] for a complete list.

3.2 RADIO LOCAL AREA NETWORKS (RLANS)

ECC/DEC/(04)08 [16] designates 5150-5350 MHz and 5470-5725 MHz for WAS/RLANs in the 5 GHz frequency band and sets technical and operational conditions. A comparable designation is given in EC Decision 2005/513/EC complemented by EC Decision 2007/90/EC [14].

The regulation in CEPT/EU distinguishes between indoor and outdoor use, and requires mitigation techniques such as dynamic frequency selection (DFS) and transmitter power control (TPC) in order to protect radar applications/systems. The technical and operational conditions within CEPT/EU are as follows:

- 5150-5350 MHz: Only indoor use, mean e.i.r.p. limited to 200 mW; DFS and TPC required above 5250 MHz;
- 5470-5725 MHz: Indoor as well as outdoor use, mean e.i.r.p. limited to 1 W; DFS and TPC required.

Indoor use is defined in ECC/DEC/(04)08 as being “inside a permanent domestic or commercial building which will typically provide the necessary attenuation to facilitate sharing with other services”. The same document clarifies in footnote 2 that “Use of RLAN inside an aircraft is also considered to be an indoor use, due to the strong attenuation offered by the aircraft, their operational conditions, and taking account of the fact that the installation and use of RLAN equipment inside an aircraft is regulated by administrations due to the specific certification required from the relevant aviation authorities.”

In 2014, Germany requested WG FM to clarify whether the regulatory conditions cover RLAN use in vehicles other than aircrafts, e.g. trains, cars, buses. The question was if the usage in a car, in a train or in a bus could be considered as indoor usage and if DFS could work while the RLAN device is in motion. An analysis, made by SRD/MG in 2015 concluded that compatibility with the meteorological radars in 5600-5650 MHz is

not ensured by the 5 GHz DFS mechanism. The specific problem of radar detection from a moving vehicle lies in the relatively long scan times of weather radars: It might take between 1 and 10 minutes for the radar beam to sweep over the same elevation angle. Within this period, RLANs, inside a moving vehicle, might miss the radar signal despite a long channel availability check of 10 min, especially when driving into the range of the radar. ETSI TC BRAN expressed the opinion that the DFS mechanism for the protection of other radars than meteorological radars might work in a moving vehicle, but studies are needed to confirm this. In 2016, WG FM endorsed the analysis made by SRD/MG and recommended RLAN use in vehicles under the current regulation for SRDs in the frequency band 5725-5875 MHz. SRD/MG finalised an explanatory paper related to RLAN equipment using the 5 GHz band in vehicles, including the usage under the existing non-specific SRD regulation [46]. WG FM agreed to request WG SE (Project Team SE24) to conduct investigations about SRD usage in cars equipped with 5.8 GHz road toll equipment, RLAN use based on the existing 5.8 GHz SRD regulation (with 25 mW power) as well as co-channel ITS communications operating in the 5855-5875 MHz band.

Previous work conducted within CEPT/ECC:

- CEPT Report 57 [6] and CEPT Report 64 [7]: Harmonised compatibility and sharing conditions for Wireless Access Systems including RLAN in the bands 5350-5470 MHz and 5725-5925 MHz ('WAS/RLAN extension bands') for the provision of wireless broadband services;
 - Existing users studied: Radiodetermination service, FSS (5725-5925 MHz), AS/ASS, Non-specific SRDs, TTT, BFWA (up to 5875 MHz), ITS;
 - New users studied: BDA2G (5855-5875 MHz), WIA (5725-5875 MHz);
- ECC Report 244 [24]: MCL calculations between RLAN and TTT, including scenario "RLAN in-car", but not under existing SRD regulation.

3.3 INTELLIGENT TRANSPORT SYSTEMS (ITS)

Regulation:

- ECC/REC/(08)01: Use of the band 5855-5875 MHz for Intelligent Transport Systems (ITS);
- Decision 2008/671/EC [15]: Harmonised use of radio spectrum in the 5 875-5 905 MHz frequency band for safety-related applications of Intelligent Transport Systems (ITS);
- ECC/DEC/(08)01: Harmonised use of the 5875-5925 MHz frequency band for Intelligent Transport Systems (ITS).

In this Report only road-ITS is considered. ITS is referred to as vehicle to vehicle, and vehicle to road infrastructure communication for road safety and traffic applications. ITS is characterised by inter-vehicle communication in highly dynamic ad hoc networks using broadcast mode, complemented by communication to a road-side infrastructure, as described in CEPT Report 20 [5]. The respective requirements, as well as compatibility studies presented in ECC Report 101 and ECC Report 228 [23], led to the following frequency designations for ITS:

- The band 5855-5875 MHz as per ECC/REC/(08)01 for ITS non-safety applications;
- The band 5875-5905 MHz as per Decision 2008/671/EC and ECC/DEC/(08)01 for traffic safety applications;
- The band 5905-5925 MHz as per ECC/DEC/(08)01 for an extension of ITS spectrum.

In this Report, only ITS within the SRD band, i.e. 5855-5875 MHz, is considered.

A set of ITS communication standards has been developed by ETSI, CEN and CENELEC under EU Mandate M/453 (2009) [50]. In November 2016, the EU released its strategy on Cooperative Intelligent Transport Systems (C-ITS) in order to ensure a coordinated deployment of cooperative, connected and automated mobility. Several member states have already started C-ITS deployment activities and test C-ITS services under real life conditions such as in the Cooperative ITS Corridor from Rotterdam-Frankfurt/M.-Vienna. It should be noted that testing in the C-ITS corridor focuses on data exchange and application layer interoperability, not on radio equipment testing. In December 2016, the C-Roads Platform was launched, which brings European Member State telecommunication Authorities and Road Authorities together in order to link C-ITS deployment activities, jointly develop and share technical specifications and work towards interoperability. The car industry has expressed its intention to deploy C-ITS equipped vehicles at full scale

by 2019 and confirmed that wireless vehicle-to-X communication will be based on ETSI ITS-G5 and IEEE 802.11p standards. Vehicle-to-x enables direct communication between vehicles (vehicle-to-vehicle) and other road users and between permanently installed infrastructure (vehicle-to-infrastructure) such as traffic lights or other traffic management systems.

3.4 ROAD TOLLING (TTT)

ERC/REC 70-03 recommends the 5795-5815 MHz frequency band for Transport and Traffic Telematics (TTT), which includes road tolling. Annex 5b identifies the band 5795-5815 MHz for TTT. Commission implementing decision EU 2017/1483 on radio spectrum for short range devices includes 5795-5815 MHz for road tolling. Technical parameters are given in the Harmonised Standard EN 300 674 [30][31][32]. The vast majority of the existing road tolling installations using DSRC technology in Europe operate throughout the whole 20 MHz.

The Directive 2004/52/EC [10] proposes the introduction of European Electronic Toll Service (EETS) that makes it mandatory for fee collection systems to use one or more of the following technologies: satellite positioning, mobile cellular communications and 5.8 GHz microwave technologies (DSRC). DSRC at 5.8 GHz is the main technology for vehicle identification and toll transactions in many European tolling systems, but is also used as complementing technology for enforcement in satellite-based tolling systems such as in Germany or Slovakia. DSRC at 5.8 GHz is used in at least in 18 European countries. According to the statistics from members of ASECAP, 29 million TTT OBUs are in use [8]. It is further noted that “the revenue for all kinds of tolling is 29 billion EUR and the TTT based tolling is a substantial part of this. Revenues from TTT road toll systems are an important income to build and maintain road infrastructure in Europe” [8].

Communication standards for DSRC at 5.8 GHz were developed in CEN TC 278 and published as CEN EN 12253 [1], CEN EN 12795 [2], CEN EN 12834 [3] and CEN EN 13372 [4]. It should be noted that the term DSRC is used in the US for ITS standards defining vehicle-to-X communication based on IEEE 802.11 and the IEEE 1609 [48] family of standards.

Within the EU, the new applications of Weights & Dimension and Smart Tachograph, which have similarities to toll enforcement, are required to use DSRC at 5795-5805 MHz according to Commission Implementing Decision 2016/799 [9], and Directive (EU) 2015/719 [13], respectively.

Previous work conducted within ECC:

- ECC Report 250 [25]: Compatibility studies between TTT/DSRC in the band 5805-5815 MHz and other systems. Radiolocation systems below 5850 MHz; BFWA in the band 5725-5875 MHz and SRDs in the band 5725-5875 MHz are covered. The following summary is given:
 - Worst-case calculations show that SRDs with 25 mW power have the potential to harmfully impact road tolling systems. Separation distances in the road tolling main beam are 0.7-1.2 km in urban environment and 2.8-5.5 km rural (in the road tolling sidelobe urban 0.3-0.6 km, rural 1.1-2.2 km). Only the potential impact to the road tolling reader was considered. With fixed road toll installations using down tilted antennas only sidelobe calculations are to be considered except for SRDs used in a car;
- TTT is also studied as existing user in aforementioned reports on ITS and RLAN (CEPT Report 57 [6] and CEPT Report 64 [7] and ECC Report 244 [24]).

3.5 OTHER SRD

ERC Recommendation 70-03 ANNEX 1: Non-specific short range devices [26] contains the band 5725-5875 MHz (Band j) for Non-specific Short Range Devices in the 5 GHz range. Maximum radiated peak power is limited to 25 mW e.i.r.p. No duty cycle limit is applied for this generic use. The Harmonised Standard EN 300 440 [29] applies to this use. This band is also designated for industrial, scientific and medical (ISM) applications as defined in ITU Radio Regulations.

4 STUDIES

The following scenarios are studied:

- Coexistence of WAS/RLAN in the band 5725-5875 MHz under SRD regulation and road olling (TTT-OBU/TTT-RSU);
- Coexistence of WAS/RLAN in the band 5725-5875 MHz under SRD regulation and non-safety road ITS.

4.1 COEXISTENCE OF WAS/RLAN IN THE BAND 5725-5875 MHZ UNDER SRD REGULATION AND ITS

4.1.1 Description of scenarios

The following scenarios describe realistic, worst-case conditions applicable to both directions of interference between ITS and RLAN. In all cases, the vehicular communication is based on the ITS-G5 standard [39]. The presented interference scenarios are independent of the applications deployed and the utilised ITS frequency band.

4.1.1.1 Scenario 1: In-car RLAN with external ITS antenna

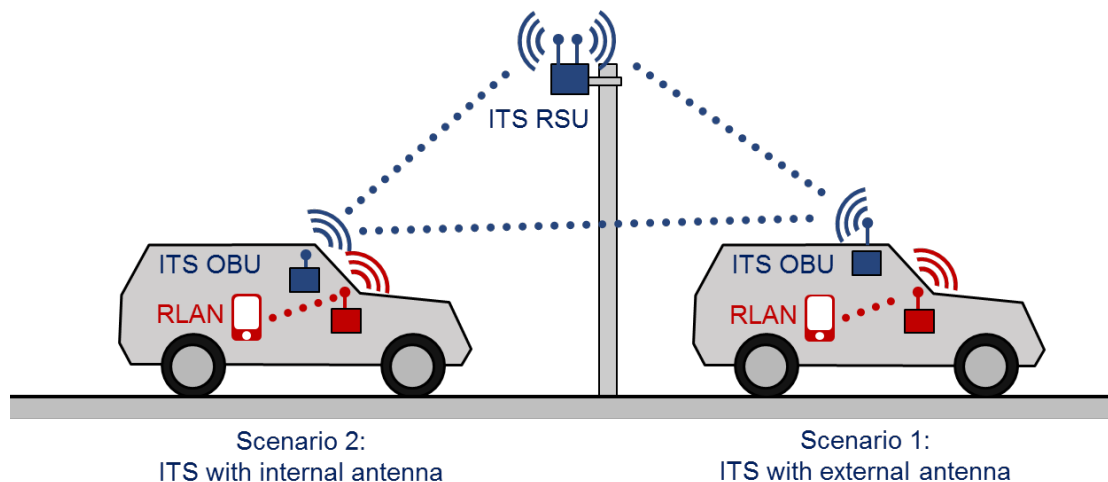

Figure 11: Scenarios 1 and 2 – In-car RLAN and ITS with external or internal antenna

One or more 5 GHz RLAN devices are situated inside the vehicle. The ITS antenna is installed on the roof of the vehicle. There can be a distance of around 1 m between the interferer and the victim. The attenuation between the ITS antenna and the 5 GHz RLAN antenna is highly variable, dependent on antenna positions, antenna performance, glass or metal on the vehicle roof etc. In this study, 20 dB extra attenuation was assumed in addition to the ordinary path loss. In this scenario, the ITS antenna could be mounted on the roof of the same vehicle containing the RLAN devices, but also on top of another vehicle.

4.1.1.2 Scenario 2: In-car RLAN with in-car ITS Antenna

This is the same as scenario 1 but with the ITS antenna integrated inside the vehicle passenger compartment. There can be a distance of 1 m between the interferer and the victim.

4.1.2 Results of MCL calculations for interference from RLAN into non- safety ITS in the band 5855-5875 MHz

For the scenarios described above, MCL calculations are performed to derive separation distances using the propagation models described in ANNEX 1:.

The effect of Transmitter Power Control (TPC) is not considered here. TPC is not mandatory for WAS/RLAN under SRD regulation. Outside the SRD band, for which 5GHz RLAN equipment is mainly manufactured, the lowest stated power level of the TPC range shall not exceed 17 dBm or 24 dBm mean e.i.r.p. (see 3.2.4.2.3 in ETSI EN 301 893 [35]), i.e. the lower end of the TPC range can be above the SRD limit.

Table 10: MCL calculations for interference from RLAN into ITS with external antenna (Scenario 1) – separation distances

Parameter	Unit	Scenario 1 - External ITS Antenna		
Emission part: RLAN (20 / 40 / 80 MHz)				
Note: There are no 40 or 80 MHz RLAN channels in the SRD band overlapping with the ITS band, see Figure 1.				
Bandwidth	MHz	20	40	80
Tx out (e.i.r.p.)	dBm	14	14	14
Wall loss (hull of the car)	dB	20	20	20
Antenna gain (0 because of e.i.r.p.)	dBi	0	0	0
Net Tx density of power e.i.r.p.	dBm/MHz	-19	-22	-25
Reception part: ITS				
Receiver bandwidth	MHz	10	10	10
Noise power	dBm	-100	-100	-100
Antenna gain	dBi	4	4	4
Noise power per MHz at antenna input	dBm/MHz	-114	-114	-114
Protection Criterion I/N	dB	-6	-6	-6
Allowable interfering power level 'I' at the receiver antenna input	dBm/MHz	-120	-120	-120
Main lobe RLAN - Main lobe ITS				
Sidelobe attenuation	dB	0	0	0
Required Attenuation	dB	101	98	95
Separation (Sep.) distances RLAN → ITS				
Sep. distance - Urban model	m	174	148	126
Sep. distance - Suburban model	m	275	226	183
Sep. distance - Rural model	m	390	304	230
Sep. distance - ETSI TR 102 492	M	190	147	114

Table 11: MCL calculations for interference from RLAN into in-car ITS (Scenario 2) – separation distances

Parameter	Unit	Scenario 2 Int. ITS Antenna		
Emission part: RLAN (20 / 40 / 80 MHz)				
Note: There are no 40 or 80 MHz RLAN channels in the SRD band overlapping with the ITS band, see Figure 1.				
Bandwidth	MHz	20	40	80
Tx out (e.i.r.p.)	dBm	14	14	14
Wall loss (hull of the car)	dB	0	0	0
Antenna gain (0 because of e.i.r.p.)	dBi	0	0	0
Net Tx density of power e.i.r.p.	dBm/MHz	1	-2	-5
Reception part: ITS				
Receiver bandwidth	MHz	10	10	10
Noise power	dBm	-100	-100	-100
Antenna gain	dBi	4	4	4
Noise power per MHz at antenna input	dBm/MHz	-114	-114	-114
Protection Criterion I/N	dB	-6	-6	-6
Allowable interfering power level 'I' at the receiver antenna input	dBm/MHz	-120	-120	-120
Main lobe RLAN - Main lobe ITS				
Sidelobe attenuation	dB	0	0	0
Required Attenuation	dB	121	118	115
Separation (Sep.) distance RLAN → ITS				
Sep. distance - Urban model	m	507	432	367
Sep. distance - Suburban model	m	925	771	642
Sep. distance - Rural model	m	1821	1476	1196
Sep. distance - ETSI TR 102 492	m	1044	808	625

4.1.3 Results of MCL calculations for interference from ITS into RLANs in the band 5855-5875 MHz

Using the interference scenarios described in section 4.1.1, Minimum Coupling Loss analysis has been performed, where ITS is the interferer and RLAN is the victim.

For each scenario, the table sets out the minimum separation required between the ITS interferer and the RLAN victim in order that the required attenuation is resolved.

Table 12: MCL calculations for interference from ITS into RLAN – separation distances

Parameter	Unit	Scenario 1 Ext. ITS Antenna	Scenario 2 Int. ITS Antenna
Emission part: ITS			
Bandwidth	MHz	10	10
Tx e.i.r.p.	dBm	33	33
Wall attenuation (hull of the car)	dB	20	0
Total net power e.i.r.p.	dBm	13	33
Reception part: RLAN			
Receiver bandwidth	MHz	20	20
Noise power	dBm	-97	-97
Antenna gain	dBi	1.3	1.3
Protection Criterion I/N	dB	-6	-6
Interference threshold at antenna	dBm	-104.3	-104.3
Required attenuation	dB	117.3	137.3
Required separation (Sep.) distances ITS → RLAN			
Sep. distance - Urban model	m	416	1215
Sep. distance - Suburban model	m	740	2486
Sep. distance - Rural model	m	1409	5687
Sep. distance - ETSI TR 102 492	m	763	4200

4.1.4 Summary - Analysis

Table 13: Summary results, MCL calculations for interference from RLAN into ITS – separation distances

Scenarios for RLAN into ITS	Results		Separation distance			
	RLAN Bandwidth	Required Attenuation	Urban	Suburban	Rural	ETSI TR 102 492
Scenario 1 – RLAN in-car (14 dBm power), ITS external antenna	20 MHz	101 dB	174 m	275 m	390 m	190 m
	40 MHz	98 dB	148 m	226 m	304 m	147 m
	80 MHz	95 dB	126 m	183 m	230 m	114 m
Scenario 2 – RLAN in-car (14 dBm power), ITS internal antenna	RLAN Bandwidth	Required Attenuation	Urban	Suburban	Rural	ETSI TR 102 492
	20 MHz	121 dB	507 m	925 m	1821 m	1044 m

Scenarios for RLAN into ITS	Results		Separation distance			
	40 MHz	118 dB	432 m	771 m	1476 m	808 m
80 MHz	115 dB	367 m	642 m	1196 m	625 m	

Table 14: Summary results, MCL calculations for interference from ITS into RLAN– separation distances

Scenarios for ITS into RLAN	Required Attenuation	Separation Distance			
		Urban	Suburban	Rural	ETSI TR 102 492
Scenario 1 – RLAN in-car, ITS external antenna	117.3 dB	416 m	740 m	1409 m	736 m
Scenario 2 – RLAN in-car, ITS internal antenna	137.3 dB	1215 m	2486 m	5687 m	4200 m

Depending on the scenario, the studies show required minimum separation distances from 416 m up to 1215 m between 5 GHz RLAN devices with 20 MHz bandwidth and ITS systems according to the urban propagation model (the interference from ITS into RLAN is dominant here). For RLAN with higher channel bandwidths the distances are slightly smaller, but this will not solve the interference problem.

For the scenario where RLAN is used on-board a vehicle equipped with ITS, the coexistence is not feasible in a co-channel case, thus requiring mitigation techniques.

In order to achieve feasible sharing conditions, there is a need for further studies, on the development of additional scenarios and on mitigation techniques to improve the compatibility between RLAN and ITS.

4.1.5 Mitigation techniques to enable coexistence of RLAN and ITS

In line with ECC Report 244, considerations on mitigation techniques for the coexistence between RLAN and ITS have focused on “listen-before-talk (LBT) process, where the potential interferer tries to detect whether a channel is busy before transmitting a data packet.

Two processes are considered for the detection mechanisms:

- Energy Detection (ED): Based on whether any energy is present above a certain threshold, regardless of the form of the signal;
- Carrier Sensing (CS): Tries to match the received signal with known signal signatures.

While CS is primarily designed to avoid interference between devices using the same technology, ED can avoid interference regardless of the technologies used for the systems.

This section describes the studies looking at possible technical requirements to enable the coexistence of RLAN and ITS based on two possible approaches:

- Generic Energy Detection without any consideration of the interferer and victim signal frames;
- Combination of energy detection and carrier sensing such as one of the Clear Channel Assessment (CCA) modes defined in IEEE 802.11 standard [48].

4.1.5.1 Generic requirements related to Energy Detection for the coexistence between RLAN and ITS

The key requirement under this approach is to determine the detection threshold, which is the signal level above which the channel is considered as busy. This is done using the generic approach outlined ECC Report 244, Annex 5.

Using the simplified approach outlined in ECC Report 244, Annex A5.1, the threshold values for RLAN as interferer and ITS as a victim are determined in Table 15.

Table 15: Detection threshold, RLAN as interferer sensing an ITS victim, simplified approach

RLAN sensing ITS								
		Victim / Wanted Transmitter (WT): ITS						
				Max. e.i.r.p. of ITS		Reduced power level		
		BW-WT (MHz)	10	10	10	10		
		PWT (dBm)	33	33	23	23		
		Noise fig. (dB)	4	4	4	4		
		Noise floor (dBm)	-100	-100	-100	-100		
		Margin (dB) (Note 2)	0	10	0	10		
		I/N (dB)	-6	-6	-6	-6		
Interfering Transmitter (IT): RLAN	BW-IT (MHz)	PIT in BW-IT (dBm)	PIT in BW-WT (dBm)	Pthr in BW-WT (dBm)				
	20	14	10.99	-84	-74	-94	-84	
	40 (Note 1)	14	7.98	-81	-71	-91	-81	
	80 (Note 1)	14	4.97	-78	-68	-88	-78	
			N RLAN	-100.00				

PIT = Power of Interfering Transmitter, PWT = Power of Wanted Transmitter, Pthr = Power threshold

Note 1: There are no 40 or 80 MHz RLAN channels in the SRD band overlapping with the ITS band, see Figure 1.

Note 2: Margin above sensitivity. Calculations are performed without margin (0 dB) and with a margin of 10 dB. For the calculation see ECC Rep. 244, Annex 5.1, equation 11.

The results show that for ITS as victim working with 23 dBm in 10 MHz at its sensitivity level, the LBT threshold values for RLAN to detect ITS would be between -78 dBm and -84 dBm in 10 MHz dependent on the RLAN bandwidth; for the 20 MHz RLAN bandwidth, this is above the noise floor of the receiver (N=-100 dBm in 10 MHz). For ITS working with 33 dBm in 10 MHz the threshold would be 10 dB higher as above. If ITS works with a certain margin above its sensitivity, then the threshold could be increased accordingly. It has to be noted that the above results are derived with 23 and 33 dBm e.i.r.p.; for lower ITS Tx power values (e.g. -10 dBm) the threshold values would be correspondingly lower (e.g. for -10 dBm ITS Tx power 33 dB lower as the 23 dBm results above).

The threshold values for ITS as interferer are given in Table 16.

Table 16: Detection threshold, ITS as interferer sensing a RLAN victim, simplified approach

ITS sensing RLAN					
			Victim / Wanted Transmitter (WT): RLAN		
			BW-WT2/MHz (Note 1)	20	20
			PWT (dBm)	14	14
			Noise Fig. (dB)	4	4
			Noise floor (dBm)	-97	-97
			Margin (dB) (Note 2)	0	10
			I/N (dB)	-6	-6
Interfering Transmitter: ITS	BW-IT (MHz)	PIT in BW-IT (dBm)	PIT in BW-WT (dBm)	Pthr in BW-WT (dBm)	
	10	23	26	-115	-105
	10	33	36	-125	-115

PIT = Power of Interfering Transmitter, PWT = Power of Wanted Transmitter, Pthr = Power threshold

Note 1: There are no 40 or 80 MHz RLAN channels in the SRD band overlapping with the ITS band, see Figure 1.

Note 2: Margin above sensitivity. Calculations are performed without margin (0 dB) and with a margin of 10 dB. For the calculation see ECC Rep. 244, Annex 5.1, equation 11.

The results show that for RLAN as victim working with 14 dBm in 20 to 80 MHz at its sensitivity level, the LBT threshold values for ITS to detect RLAN would be between -105 dBm and -115 dBm in 20 MHz; for the 20 MHz RLAN bandwidth, this is 19 dB below the noise floor of the ITS receiver (N=-97 dBm in 20 MHz). For ITS working with 33 dBm in 10 MHz the threshold would be 10 dB lower as above. If RLAN is working with a certain margin above its sensitivity, then the threshold could be increased accordingly.

4.1.5.2 Clear Channel Assessment in IEEE 802.11 - requirements for the coexistence between RLAN and ITS

A fundamental principle employed in the IEEE 802.11 (“Wi-Fi”) standard is that of Carrier Sense Multiple Access with Collision Avoidance (CSMA/CA). This is a “listen-before-talk” process, where the IEEE 802.11 system tries to detect whether a channel is busy before transmitting a data packet. This process, often referred to as Clear Channel Assessment (CCA), uses Carrier Sensing (CS) and Energy Detection (ED) to detect whether a channel is transitioning from idle to busy (see IEEE 802.11-2016 [48], paragraph 17.3.10.6).

CS tries to match the received signal with known training (preamble) signal signatures of other IEEE 802.11 devices. ED detects whether any energy is present above a certain threshold, regardless of the form of the signal. If the medium is determined to be busy, either by CS or ED, then the device must wait (defer) for a period of time called the back off. Clear Channel Assessment (CCA) has proven to be a very effective method for medium sharing, particularly for lightly loaded Wi-Fi networks.

RLAN devices can use channels with 20, 40, 80 or 160 MHz bandwidths (as defined in the IEEE 802.11ac specification). Within the SRD band from 5725 MHz to 5875 MHz, a 160 MHz channel is not available. In order to use channels wider than 20 MHz CCA must be performed across a wider frequency range. To achieve this, the IEEE 802.11ac specification defines several CCA channels; a Primary CCA channel and one or more Secondary CCA channels. For example, if a RLAN device is to operate in a 80 MHz bandwidth, it must perform CCA in the Primary (20 MHz) channel as well as in 3 adjacent 20 MHz Secondary channels.

The IEEE 802.11 specification [48] defines detection levels for CS and ED as shown in Table 17.

Table 17: IEEE 802.11 CCA detection levels

	CS detection level (dBm)	ED detection level (dBm within 20 MHz)
CCA sensitivity for signals occupying the primary 20 MHz channel	-82 (see Note)	-62
CCA sensitivity for signals not occupying the primary 20 MHz channel	-72	-62

Note: There are further bandwidth-dependent thresholds defined for 40/80/160 MHz frames defined in Table 21-27 of [48]

As it can be seen in Table 17, there is a significant difference between detection levels using CS and ED. In the Primary Channel, there is a 20 dB difference between detection thresholds. Put in terms of range, if a device is operating in free space (1/R² path loss) then a preamble can be detected using CS at ten times the distance that energy can be detected using ED. Therefore, CS of the preambles offers far better protection against interference than ED.

Studies have been started on interference avoidance techniques currently employed in 5 GHz RLAN systems and their applicability to ITS. ETSI has published first results and open issues in ETSI TR 103 319 [45]. This might be a starting point for further work.

4.1.5.3 Applicability of CCA to ITS

ITS adopted the IEEE 802.11p [49] Physical layer (PHY) specification². IEEE 802.11p has its preamble structure in common with other members of the IEEE 802.11 OFDM family. Hence, detection of the IEEE 802.11p preamble is in principle possible. However, the following issues need to be resolved in order to achieve this:

- 1 Neither IEEE 802.11n nor IEEE 802.11ac is capable of performing CCA on a 10 MHz channel; both use a minimum channel bandwidth of 20 MHz. For the purpose of ITS detection, a 10 MHz CCA mode would have to be added. This would be for the purpose of carrier sensing OFDM frames using a 10 MHz channel width, like ITS, and would not require adding a 10 MHz transmit option for the IEEE 802.11n or IEEE 802.11ac PHY. Furthermore, CCA has to be performed on all 10 MHz ITS channels within the operating bandwidth.
- 2 The IEEE 802.11ac specification requires CS to detect frames with received power at or above -82 dBm, a threshold that would drop 3 dB to -85 dBm in a 10 MHz channel. But, fielded ITS systems have been demonstrated to successfully decode frames received below -90 dBm. In this case, a ITS system would detect another ITS signal at almost twice the distance that a minimum conforming Wi-Fi system would detect ITS. This difference in detection range could lead to scenarios in which a Wi-Fi signal would interfere with an ITS system's ability to receive ITS frames. For this reason, it is imperative that a Wi-Fi system should have CCA sensitivity levels which are good enough to provide a similar level of protection to that provided by other co-channel ITS devices. It should be noted that the effects of this mitigation have not been assessed as yet for providing adequate protection to safety ITS applications.
- 3 The reciprocal problem also exists, i.e. ITS systems use CCA to sense other ITS transmissions, but are not capable of detecting the preamble of wider bandwidth Wi-Fi signals. Wi-Fi signals of wider bandwidth

² The amendment IEEE 802.11p has been incorporated into the main IEEE 802.11 standard, where it is named "OCB" mode, i.e. operation outside the context of a basic service set.

would only be subject to energy detection at -65 dBm. So, it is likely that ITS systems could interfere with co-channel WiFi users.

- 4 The concept of CCA is to assess whether the medium is busy to allow a method for gaining access to the channel. Modern IEEE 802.11 systems employ methods to try to give some types of packet traffic a priority over others (e.g., EDCA). ITS traffic would need to have a higher priority identified for its traffic in the case where WiFi services have similar bandwidths and operate co-channel with ITS.
- 5 The detection of ITS should consider the sensitivity and dynamic conditions of ITS, i.e. a highly dynamic environment, including effects from moving signal sources on the transmitted and received signals.

4.1.6 Summary

Regarding ITS vs RLAN (under generic SRD regulation) coexistence, MCL calculations for both directions of interference have been performed and showed the need for significant separation distances if compatibility is dependent upon protection to an I/N level of -6 dB. No studies have been conducted to analyse the actual effects of this I/N level being reached due to intermittent interference.

The work on mitigation techniques initiated in ECC Report 244 [24] to improve the compatibility between individual RLAN devices and ITS have been included into the present report and adapted to the context of RLAN use in cars under SRD regulation. These studies have focussed on “listen-before-talk” process, where the potential interferer tries to detect whether a channel is busy before transmitting a data packet. Calculations provided in the present report evaluate generic Energy Detection (ED) without any consideration of the interferer and victim signal frames: under the considered assumptions, preliminary studies show that in the case of an energy detection threshold of -90dBm/10MHz for a RLAN system operating with 14 dBm within 20MHz, an ITS device with 23dBm/10MHz is not reliably detected. This could become problematic especially in case where the RLAN and the ITS devices are located in different vehicles. Further consideration is required, including the feasibility of such a detection threshold and its impact on the RLAN operation. The detailed information about the requirements for a sensing procedure and analysis of the hidden node issues can be found in Annex 5 of the ECC Report 244.

Combination of energy detection and carrier sensing such as one of the Clear Channel Assessment (CCA) modes defined in IEEE 802.11 standard depend on the ability to mutually detect the preamble of the other application, which is currently not applicable, since IEEE 802.11 uses 20 MHz and higher bandwidths, while ITS uses 10 MHz bandwidth.

Time domain effects with regards to sensing procedures (e.g. listening time, avoidance time) have been studied in ETSI TR 103 319 [45]. Also the applicability of channel access mechanism has been studied. It was found that it is important to distinguish between interference before ITS detection and interference after ITS detection. The mitigation methods described in ETSI TR 103 319, namely “Detect and Vacate” (D&V) and “Detect and Mitigate” (D&M) differ in post-detection-mitigation, where it is obvious that a D&V eliminates interference from RLAN into ITS in the post-detection phase. For the pre-detection phase it was found that a modest amount of extra inter-packet spacing in the order of a few hundred microseconds already improves detection and helps to reduce the pre-detection interference.

An automobile manufacturer that is in control of the RLAN and ITS deployment in its vehicles could choose a configuration where RLAN uses only channels outside the ITS band. This seems to be the desired case, since use cases for in-car RLAN such as rear-seat entertainment require high bandwidths and the only 80 MHz channel within the SRD band lies outside the ITS band.

The effect of RLAN deployments in cars on POD (Probability of Detection) and the associated aggregate interference environment have not yet been considered and may be an issue for further work.

4.2 COEXISTENCE OF WAS/RLAN IN THE BAND 5725-5875 MHZ UNDER SRD REGULATION AND ROAD TOLLING (TTT)

4.2.1 Description of the scenario: RLAN on-board a vehicle

The following describes realistic, worst-case scenario applicable to both directions of interference between road tolling and RLANs on-board vehicles.

4.2.1.1 Scenario 1

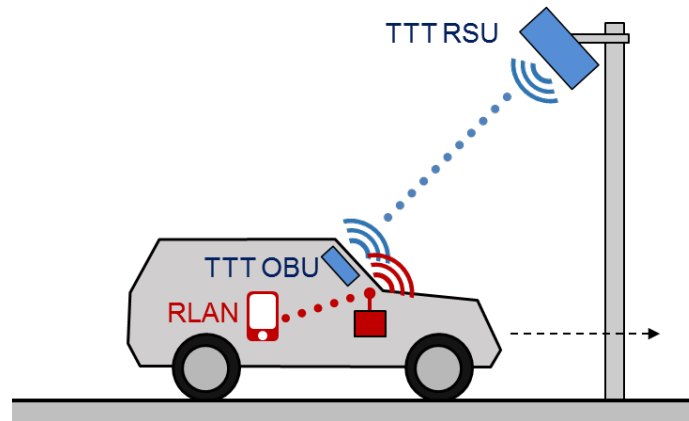

Figure 12: RLAN and TTT - Scenario 1

In this worst-case scenario, the 5 GHz RLAN transmitter and the TTT on-board unit are found inside the same vehicle. If the RLAN device is transmitting within the road tolling communication zone, its transmission would radiate through the vehicle window interfering directly with uplink communications to receiver antenna of the tolling Road Side Unit (RSU).

4.2.1.2 Scenario 2

In this scenario, the focus is on RLAN transmissions coming from a second vehicle, which is outside the communication zone of road tolling, while a road tolling transaction is ongoing in the first vehicle. The assumption is:

- Vehicle 1 within the tolling communication zone, DSRC OBU active, RLAN inactive (due to detection of the tolling signal) or not present.
- Vehicle 2 outside the tolling communication zone, DSRC OBU inactive, RLAN active.

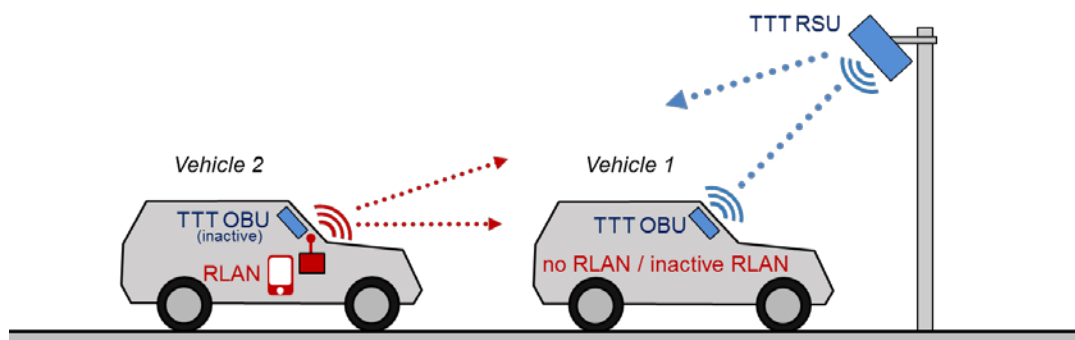

Figure 13: RLAN and TTT - Scenario 2

4.2.2 Results of MCL calculations for interference from RLAN into road tolling RSUs

MCL calculations are performed to derive separation distances between an RLAN and TTT RSU using the propagation models described in ANNEX 1. The obtained results for both scenarios 1 and 2 are depicted in Table 18.

The effect of TPC is not considered here. TPC is not mandatory for WAS/RLAN under SRD regulation. Outside the SRD band, for which 5GHz RLAN equipment is mainly manufactured, the lowest stated power level of the TPC range shall not exceed 17 dBm or 24 dBm mean e.i.r.p. (see 3.2.4.2.3 in ETSI EN 301 893 [35]), i.e. the lower end of the TPC range can be above the SRD output power limit.

Table 18: MCL calculations for interference from RLAN into TTT RSU – separation distances

Parameter	Unit	Scenario 1 / Scenario 2		
Emission part: RLAN (20 / 40 / 80 MHz bandwidth)				
Bandwidth	MHz	20	40	80
Tx out (e.i.r.p.)	dBm	14	14	14
Windscreen attenuation	dB	3	3	3
Antenna gain (0 because of e.i.r.p.)	dBi	0	0	0
Net Tx density of power e.i.r.p.	dBm/MHz	-2	-5	-8
Reception part: TTT RSU				
Receiver bandwidth	MHz	0.5	0.5	0.5
Noise power	dBm	-115	-115	-115
Antenna gain (includes 3 dB polarisation discrimination)	dBi	10	10	10
Noise power per MHz at antenna input	dBm/MHz	-122	-122	-122
Protection Criterion I/N	dB	-6	-6	-6
Allowable interfering power level 'I' at the receiver antenna input	dBm/MHz	-128	-128	-128
Main lobe RLAN - sidelobe TTT RSU				
Sidelobe attenuation	dB	15 / 0	15 / 0	15 / 0
Required Attenuation	dB	111 / 126	108 / 123	105 / 120
Separation (Sep.) distance RLAN → TTT RSU				
Sep. distance - Urban model	m	297 / 662	253 / 564	215 / 480
Sep. distance - Suburban model	m	504 / 1251	420 / 1043	350 / 869
Sep. distance - Rural model	m	886 / 2579	692 / 2091	540 / 1695
Sep. distance - ETSI TR 102 492	m	445 / 1598	344 / 1236	266 / 956

4.2.3 MCL Calculations for interference from RLAN into road tolling OBUs

MCL calculations for Interference from RLAN into a TTT/DSRC OBU in a different vehicle (scenario 2) are depicted in Table 19.

Table 19: MCL calculations for Interference from RLAN into TTT/DSRC OBU in a different vehicle

Parameter	Unit	Scenario 2		
		RLAN 20 MHz	RLAN 40 MHz	RLAN 80 MHz
Emission part: WAS/RLAN under SRD regulation (transmitter in car within TTT sidelobe)				
Bandwidth	MHz	20	40	80
Tx out, e.i.r.p.	dBm	14	14	14
Antenna gain	dBi	0	0	0
Windscreen attenuation (2 vehicles, 3dB each)	dB	6	6	6
Bandwidth correction		13	16	19
Net Tx power density	dBm/MHz	-5	-8	-11
Reception part: TTT OBU (in different vehicle)				
Receiver bandwidth	MHz	1	1	1
Receiver sensitivity	dBm	-60	-60	-60
Antenna gain	dBi	0	0	0
Bandwidth correction		0	0	0
Min Carrier per MHz at antenna input	dBm/MHz	-60	-60	-60
Protection criterion				
Criterion C/I	dB	6	6	6
Allowable Interfering power level 'I' at receiver antenna input	dBm/MHz	-66	-66	-66
Required Attenuation				
Sidelobe attenuation	dB	0	0	0
Required attenuation	dB	61	58	55
Separation (Sep.) distance RLAN → TTT OBU in different vehicle (see note)				
Sep. distance - Urban model	m	5	3	2
Sep. distance - Suburban model	m	5	3	2
Sep. distance - Rural model	m	5	3	2
Sep. distance - ETSI TR 102 492	m	5	3	2

Note: This calculation reflects the worst-case positioning, where the interference signal radiates from the front into the TTT OBU, e.g. from an RLAN in another vehicle in front of the victim.

4.2.4 Results of MCL calculations for interference from road tolling into RLAN

Using the interference scenarios described in section 4.3.1, the results of a Minimum Coupling Loss analysis, where road tolling is the interferer and RLAN the victim, is provided below.

Table 20 below sets out the minimum separation required between the road tolling interferer and the RLAN victim in order that the required attenuation is resolved.

Table 20: MCL calculations for interference from road tolling into RLAN – separation distances

Parameter	Unit	Scenario 1		
		RLAN 20 MHz	RLAN 40 MHz	RLAN 80 MHz
Emission part: road tolling				
Bandwidth	MHz	1	1	1
TX e.i.r.p.	dBm	33	33	33
Windscreen attenuation	dB	3	3	3
Sidelobe attenuation	dB	15 / 0	15 / 0	15 / 0
Net Tx power e.i.r.p.	dBm	0 / 15	0 / 15	0 / 15
Reception part: RLAN				
Receiver bandwidth	MHz	20	40	80
Noise power	dBm	-97	-97	-97
Antenna gain	dBi	1.3	1.3	1.3
Polarisation discrimination	dB	3	3	3
Protection Criterion I/N	dB	-6	-6	-6
Interference threshold	dBm	-101.3	-101.3	-101.3
Required attenuation	dB	131.3 / 116.3	119.3 / 134.3	122.3 / 137.3
Separation (Sep.) distance TTT RSU → RLAN				
Sep. distance - Urban model	m	395 / 881	464 / 1036	545 / 1217
Sep. distance - Suburban model	m	696 / 1728	836 / 2074	1003 / 2489
Sep. distance - Rural model	m	1314 / 3742	1621 / 4616	2000 / 5695
Sep. distance - ETSI TR 102 492	m	701 / 2518	906 / 3254	1171 / 4207

4.2.5 Results of MCL calculations on the detection of TTT by RLAN

The following table shows the range where RLAN can detect TTT based on energy detection with a threshold of -62 dBm.

Table 21: MCL calculations for Detection of TTT by RLAN in car

Parameter	Unit	Scenario 2		
		RLAN 20 MHz	RLAN 40 MHz	RLAN 80 MHz
Emission part: TTT RSU				
Bandwidth	MHz	1	1	1
Tx out, e.i.r.p.	dBm	33	33	33
Sidelobe attenuation	dB	15	15	15
Antenna gain	dBi	0	0	0
Windscreen Attenuation	dB	3	3	3

Parameter		Scenario 2		
Bandwidth correction		0	0	0
Net Tx power density	dBm/MHz	15	15	15
Reception part: WAS/RLAN (receiver in car within TTT sidelobe)				
Receiver bandwidth	MHz	20	40	80
Energy detect threshold	dBm	-62	-62	-62
Antenna gain	dBi	0	0	0
Bandwidth correction		13	16	19
C min per MHz at antenna input	dBm/MHz	-75	-78	-81
Maximum Attenuation	dB	90	93	96
Detection (Det.) Range (RLAN sensing TTT RSU)				
Det. distance - Urban model	m	93	112	133
Det. distance - Suburban model	m	129	160	197
Det. distance - Rural model	m	130	184	259
Det. distance - ETSI TR 102 492	m	74	96	124

4.2.6 Results of lab measurements including road tolling and RLAN

4.2.6.1 Equipment

The following TTT/DSRC equipment has been used:

- a) A CEN DSRC Road-side unit supporting DSRC Standards EN 12253 [1], EN 12795 [2], EN 12834 [3], EN 13372 [4], and operating on DSRC channels 5797.5 MHz, 5802.5 MHz, 5807.5 MHz, 5812.5 MHz.
- b) CEN DSRC On-board unit.
- c) Additional equipment for analysis and measurement: a computer to record DSRC transaction success and transaction duration. The RLAN access point is connected with a laptop for configuration and for traffic generation. A (portable) spectrum analyser is used to observe and check the used channels and the channel occupancy. The spectrum analyser is equipped with an external antenna for radiated measurements.

4.2.6.2 Measurement setup of the lab tests

In the lab test setup, the DSRC RSU is mounted on a rack, pointing downwards towards the DSRC OBU. The DSRC OBU as well as the RLAN equipment is placed on a table. The spectrum analyser is placed on the table as well. Data traffic over the RLAN link was generated with iPerf 3 (www.iperf.fr) in form of a TCP stream generated by iPerf3. The RLAN equipment was configured to a specific channel, then for each of the 4 DSRC channels, 5 DSRC transactions were performed.

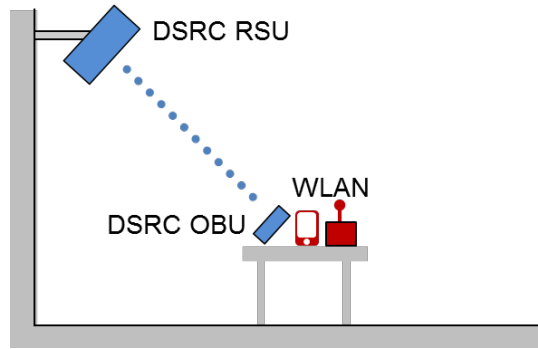

Figure 14: Lab measurement setup

4.2.6.3 Measurement results of the lab tests

The results of the lab tests contain averages over 20 tolling transactions, 5 for each DSRC channel. A RLAN output power level of 25 mW was used. Measurements on RLAN channel 161 were conducted with and without DFS. Table 22 shows the results. The tests showed that channel 161 was not used by RLAN. Having DFS turned on, the RLAN access point switches to another channel. This channel switch is not necessarily a false alarm of the radar detection part of DFS, but could be more likely attributed to the "uniform spreading" functionality that is also part of DFS and tries to avoid an occupied channel in this case. Without DFS activated, RLAN remains idle. All tolling transactions were successful. While small delays in DSRC transactions are tolerable in a fixed setting where the vehicle waits in front of a barrier, large delays would break a tolling transaction in a free flow situation where the vehicle passes through the communication zone in short time³. Cf. Figure 9 for typical tolling transaction durations.

Table 22: Lab test results

Test setup						WLAN Tx power 25mW				
Test location	SRD band	WLAN Channel	Center Frequency	Bandwidth	DFS	Test runs	DSRC Errors	Delays >1sec	Delays >200ms	Avg. DSRC Transaction Time
Lab		46	5,230 GHz	20 MHz	no	20	0	0	1	58,3
Lab		48	5,240 GHz	20 MHz	no	20	0	1	3	167,6
Lab		64	5,320 GHz	20 MHz	no	20	0	0	4	131,3
Lab		140	5,700 GHz	20 MHz	no	20	0	0	3	152,1
Lab	X	157	5,785 GHz	20 MHz	no	20	0	0	3	117,8
Lab	X	161-->36	5,805 GHz	20 MHz	yes	20	0	0	1	81,3
Lab	X	161-->idle	5,805 GHz	20 MHz	no	20	0	-	-	-
Lab	X	165	5,825 GHz	20 MHz	no	20	0	0	2	110,7

4.2.7 Results of field measurements including road tolling and RLAN

4.2.7.1 Measurement setup of the Spanish Motorway tests

The Spanish field tests were conducted with normal DSRC road-side units mounted at their original locations, on a toll plaza on the motorway C-32 and on a free-flow portal on the motorway AP-7 in Spain.

³ A car driving at 100km/h stays 180ms within a communication zone of 5m length, a truck driving 80km/h stays 181ms within a 4m zone. See ETSI TR 102 960 [44], p. 72 for communication zones.



Figure 15: Toll plaza on the Spanish motorway C-32



Figure 16: Toll gantry on the Spanish motorway AP-7

For the field tests, tolling OBU and RLAN equipment were placed into a vehicle. RLAN equipment is placed on the dashboard close to the windscreen. A smartphone connected to RLAN is placed on a phone holder next to the dashboard. The DSRC OBU is attached behind the windscreen.

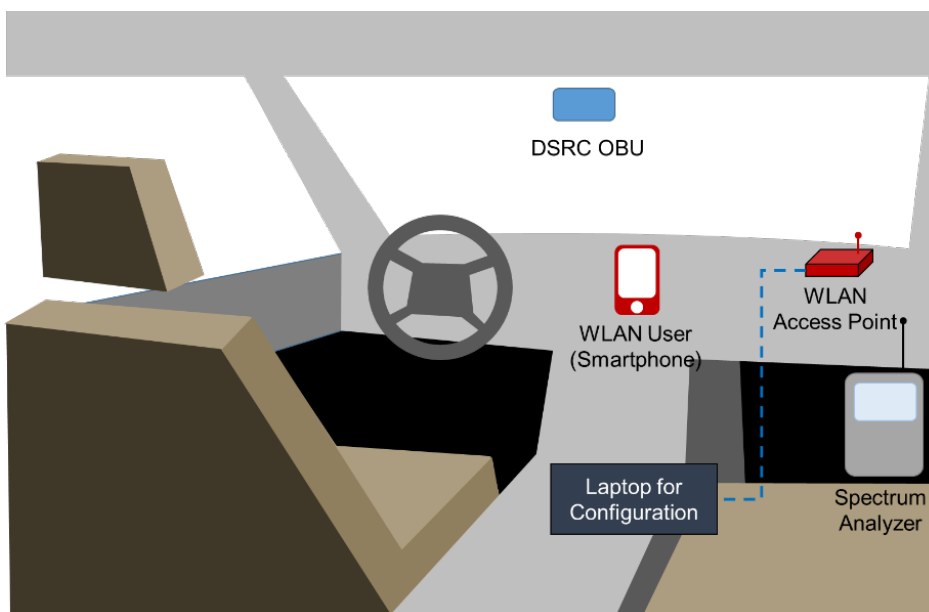

Figure 17: Measurement setup for Spanish motorway field tests

On the toll plaza, different passes were made with the vehicle to see the effect that the interfering access point has on the OBU readings. For each tested RLAN channel, five measurements were conducted for each of the four DSRC channels, which sums up to 20 test runs (as indicated in Table 23). DSRC transaction times and transaction delays were averaged over the test runs.

The free-flow tests were repeated only once for each RLAN channel using the default DSRC channel.

4.2.7.2 Measurement results of the Spanish motorway field tests

Table 23 and Table 24 show results of the tests at a toll plaza and in multi-lane free flow tolling.

Table 23: Results of the Spanish field tests at a toll plaza

Test setup						WLAN Tx power 25mW				
Test location	SRD band	WLAN Channel	Center Frequency	Bandwidth	DFS	Test runs	DSRC Errors	Delays >1sec	Delays >200ms	Avg. Transaction Time
Plaza	X	157	5,785 GHz	20 MHz	no	20	0	0	5	152,0
Plaza	X	161-->36	5,805 GHz	20 MHz	yes	20	0	0	3	118,6
Plaza	X	161-->idle	5,805 GHz	20 MHz	no	20	0	-	-	-
Plaza	X	165	5,825 GHz	20 MHz	no	20	0	0	3	144,5

Slight average tolling transaction delays (i.e. increase in the duration of a transaction) could be observed when RLAN was operated at adjacent channels. RLAN was observed to react to tolling when using the 20 MHz RLAN channel 161: either the RLAN channel changed or the RLAN transmission stopped.

Table 24: Results of the Spanish field tests on the motorway with multi-lane free flow (MLFF) tolling

Test setup						WLAN Tx power 25mW				
Test location	SRD band	WLAN Channel	Center Frequency	Bandwidth	DFS	Test runs	DSRC Errors	Delays >1sec	Delays >200ms	Avg. DSRC Transaction Time
MLFF		disabled	-	-	-	1	0	0	0	65,0
MLFF		64	5,320 GHz	20 MHz	no	1	0	0	0	71,0
MLFF		140	5,700 GHz	20 MHz	no	1	0	0	0	83,0
MLFF	X	157	5,785 GHz	20 MHz	no	1	0	0	0	51,0
MLFF	X	161-->36	5,805 GHz	20 MHz	yes	1	0	0	0	51,0
MLFF	X	161-->idle	5,805 GHz	20 MHz	no	1	0	0	0	71,0
MLFF	X	165	5,825 GHz	20 MHz	no	1	0	0	0	67,0
MLFF		62	5,300 GHz	40 MHz	no	1	0	0	0	59,0
MLFF		134	5,670 GHz	40 MHz	no	1	0	0	0	49,0

Tests on the motorway when passing a tolling gantry (multi-lane free flow, MLFF) showed no impact on tolling transaction performance. In contrast to the toll plaza tests, only single runs were performed without repetition. One should note that careful consideration should be taken into account when dealing with the results, since the test was not repeated. Similar to the toll plaza test, RLAN was observed to react when using the 20 MHz RLAN channel 161: either the RLAN channel changed or the RLAN transmission stopped. Tolling transaction performance was recorded only for the testing vehicle containing both RLAN and TTT OBU. When this vehicle reached the tolling communication zone, RLAN already stopped using channel 161. The impact of an active RLAN on channel 161 (causing in-band interference) while another vehicle is within the communication zone could not be tested in this setup.

4.2.7.3 Measurement setup of the German motorway field tests

The German measurements⁴ were conducted on the A9 using RLAN equipment only. The purpose of the test was to measure the impact of tolling road-side equipment on in-vehicle RLAN. No data was recorded on the tolling equipment. During the drive on the A9 motorway segment, the test vehicle passes through a DSRC gantry on the northbound lane, returns and passes by the same gantry when driving back on the southbound lane.

Two sets of equipment were used in the measurements: The received power of the TTT signal was measured using a software-defined radio device with 3 dB stub antenna placed behind the windscreen. The RLAN throughput was measured with an RLAN access point (based on IEEE 802.11ac) and attached devices.

The RLAN equipment was placed in a normal passenger vehicle without infrared reflective windscreen. A RLAN access point with an attached monopole antenna was placed on the rear seat. Smartphones were placed on the companion seat.

An RLAN output power of 13 dBm was used (result of 10 dBm chip output, additional antenna gain and cable losses). Data traffic over the RLAN link was generated using iPerf from a notebook attached to the RLAN access point. Other than in the Spanish measurements, only RLAN at 80 MHz bandwidth (according to IEEE 802.11ac) was tested. The only 80MHz channel in the SRD band is channel 155, which ranges from 5735 MHz to 5815 MHz and fully contains the tolling band. The usage of the 80MHz bandwidth is announced on the "primary channel" 149 (a 20MHz channel).



Figure 18: DSRC Gantry on the German motorway A9

4.2.7.4 Measurement results of the German motorway field tests

The measurement results from the German field tests show how RLAN is affected by the tolling signal when passing by a TTT/DSRC gantry. It could be observed that the TTT/DSRC signal exceeds the threshold of -62 dBm for clear channel assessment (CCA) in the vicinity of the gantry. The steady increase in received

⁴ Some measurement results were part of a German contribution to CPG PT-D, September 2017. https://cept.org/Documents/cpg-pt-d/38075/ptd-17-105r1_studies-under-wrc-19-agenda-item-116-compliance-with-outdoor-limit-5-150-5-250-mhz

power when driving towards the gantry and the sharp decrease under the gantry reflects how the down-tilted DSRC RSU antenna covers the communication zone in front of the gantry.

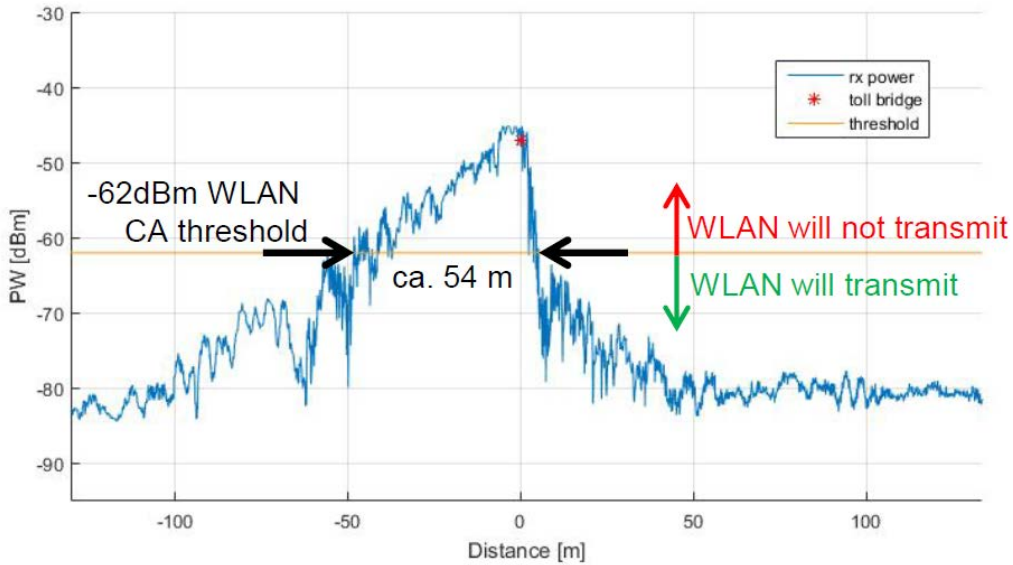

Figure 19: RLAN Rx power when passing a TTT gantry on the German A9

The following figures show the throughput timeline of an RLAN link using 80 MHz bandwidth (data channel 155, primary channel 149) while the vehicle is passing a TTT gantry. It could be observed that the RLAN throughput decreases dramatically to almost 0 in the area around the TTT gantry. This can be attributed to the TTT/DSRC signal becoming stronger when approaching the gantry. First the DSRC signal is probably causing an increased interference level resulting in lower throughput. When the DSRC signal exceeds the CCA threshold, RLAN stops transmitting. Figure 20 shows the achieved RLAN throughput on a map, which illustrates that RLAN throughput is decreasing around the tolling location. A bandwidth reduction of RLAN from an 80 MHz channel to a 40 MHz or 20 MHz channel outside the TTT band (which is possible by the 802.11ac standard when two RLAN access points share the spectrum) could not be observed in this case.

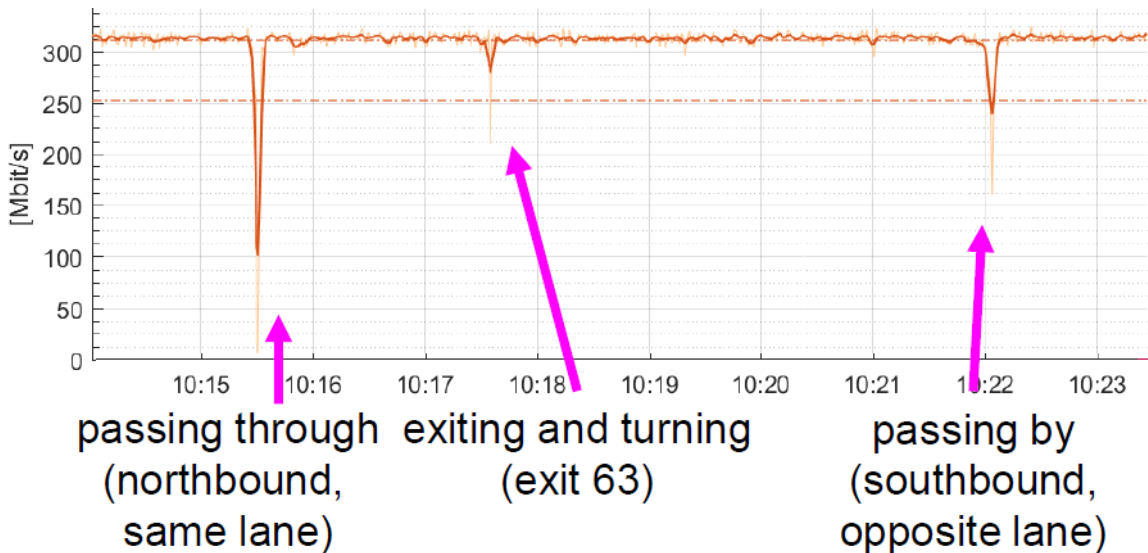

Figure 20: Overall timeline of RLAN throughput for the whole A9 segment

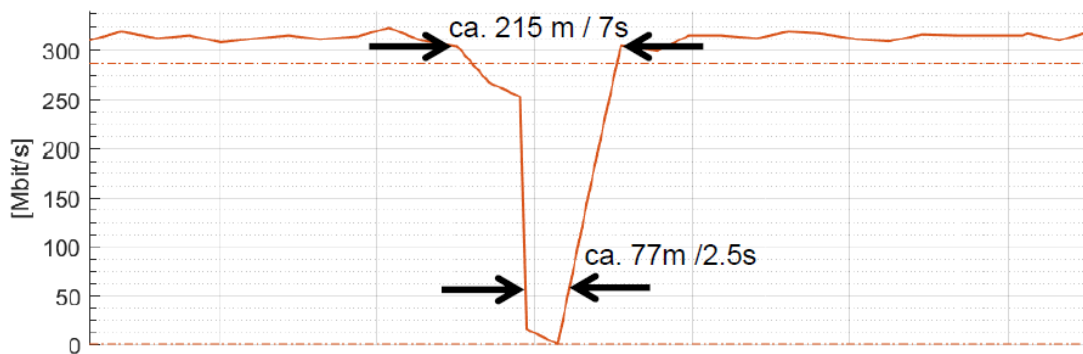

Figure 21: Detailed timeline of RLAN throughput when passing the TTT gantry on the German A9

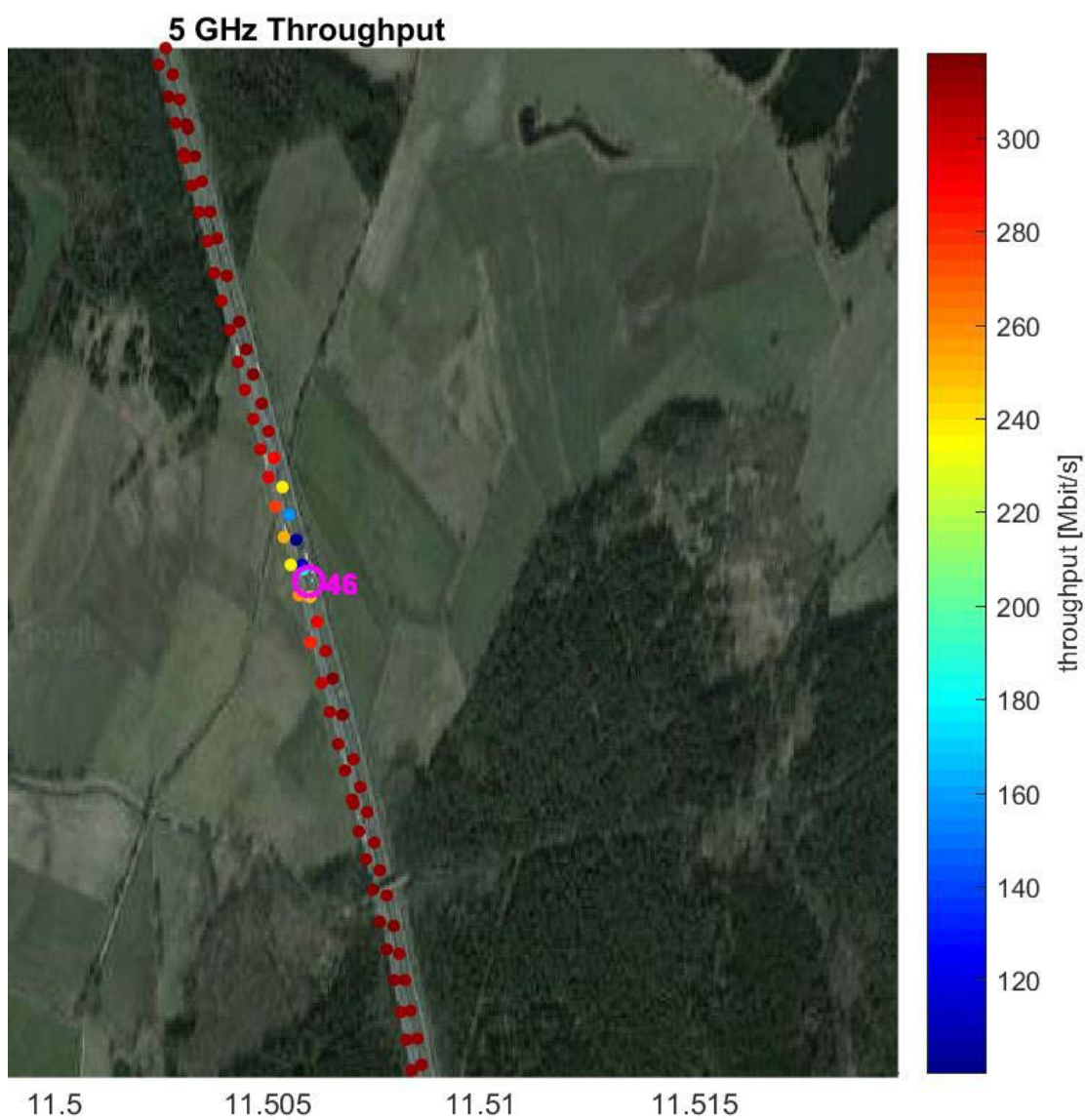

Figure 22: Map of RLAN throughput around a TTT gantry on the German A9

4.2.8 Summary - Analysis

4.2.8.1 Summary of MCL calculations

Table 25: Summary results, MCL calculations for interference from RLAN into road tolling – separation distances

Scenario	Urban		
RLAN in-car (14 dBm power) → Road tolling (TTT RSU)	RLAN Bandwidth	Separation distance (all models)	
		Sidelobe attenuation: 15 dB	Sidelobe attenuation: 0 dB
	20 MHz	297 m - 886 m	662 m - 2579 m
	40 MHz	253 m - 692 m	564 m - 2091 m
	80 MHz	215 m - 540 m	480 m - 1695 m

Table 26: Summary results, MCL calculations for interference from road tolling into RLAN – separation distances

Scenario	Urban		
Road tolling (TTT RSU) → RLAN in-car	RLAN Bandwidth	Separation distance (all models)	
		Sidelobe attenuation: 15 dB	Sidelobe attenuation: 0 dB
	20 MHz	395 m - 1314 m	881 m - 3742 m
	40 MHz	464 m - 1621 m	1036 m - 4614 m
	80 MHz	545 m - 2000 m	1217 m - 5695 m

The MCL calculations showed required, minimum separation distances of 297 m (RLAN → TTT) and 395 m (TTT → RLAN) in urban environment between 5 GHz RLAN devices with 20 MHz bandwidth and road tolling systems in the sidelobe. The detection distance at which RLAN perceives the TTT/DSRC signal above the energy detect threshold of -62dBm covers the communication zone, but it is slightly smaller (74 m - 130 m) than the separation distance, i.e. there is the possibility that one vehicle interferes with the TTT RSU while another vehicle is within the tolling zone. The separation distance between RLAN and a TTT OBU in a different vehicle is rather low (5 m) in this context. Table 27 and Figure 23 below summarise these findings. Separation distances depicted in Table 27 describe the minimum and maximum values calculated from the attenuation value using the different propagation models in ANNEX 1:

Table 27: Summary of separation distances and detection range for RLAN (20 MHz) and TTT

Range	Attenuation	Distance / Width
TTT/DSRC communication zone (R_c)	-	4 m - 5 m (ETSI TR 102 960 [44], p. 72.)
Range of TTT/DSRC detection (R_d)	90 dB (sidelobe)	74 m - 130 m
Separation distance RLAN → TTT OBU (R_{OBU})	61 dB	5 m
Separation distance RLAN → TTT RSU (R_{RSU})	111 dB (sidelobe)	297 m - 886 m
Separation distance TTT RSU → RLAN	116.3 dB (sidelobe)	395 m - 1314 m

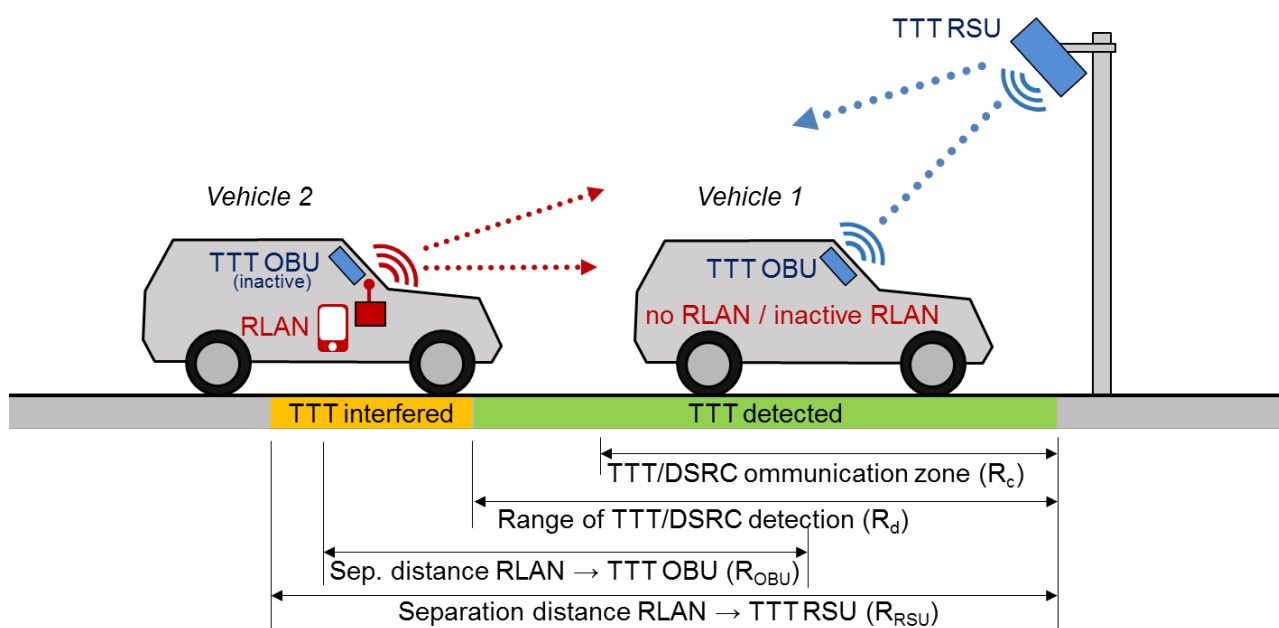

Figure 23: Separation distances and detection range for RLAN and TTT

4.2.8.2 Summary of lab and field measurements

Lab and field measurements showed the following:

- In the lab and field test, no TTT transaction failures under the considered scenarios could be identified when RLAN is operated on 20 MHz channels adjacent to and outside the TTT band with 25 mW output power. Some settings show an increased TTT transaction duration, which could lead to transaction failures when the vehicle is only for short time in the tolling communication zone. The effect of In-band interference could not be tested, since RLAN stopped transmitting or changed the channel in presence of the TTT signal;
- On RLAN channels that overlap the TTT band, the RLAN equipment was observed to stop transmitting in the vicinity of a TTT/DSRC RSU or changes the channel in case the DFS is active. This could be observed for RLAN at 25 mW using the 20 MHz channel 161 which exactly overlaps the TTT band. It could also be observed with RLAN at 20 mW, using a 80 MHz channel 151, which includes the TTT band. The avoidance of channels 161 and 155 in the vicinity of a tolling station could be attributed to energy detection (as part of the IEEE 802.11 clear channel assessment) being triggered by the TTT/DSRC signal;
- Lab tests conducted by the German Federal Network Agency⁵ show that if CSMA (e.g. the clear channel assessment of RLAN) is not active, the TTT/DSRC transactions are affected. It was found that when assuming a power level which is based on the regulation for non-specific SRDs (a level of 14 dBm e.i.r.p. is allowed, a level of 12.7 dBm e.i.r.p. was used) interferences always occur when the transmitter bandwidth of the interfering signal overlaps the TTT signal bandwidth;
- Field tests with only few repetitions (Motorway tests in Spain with only one test run per RLAN channel) are not statistically significant. These measurements are the only ones available at the time of writing this Report.

In order to achieve feasible sharing conditions, there is a need for further studies on the development of additional scenarios and on mitigation techniques to ensure the compatibility between RLAN and road tolling.

⁵ Doc. FM(17)100. Impact of radio applications, operated in the 5.8 GHz range, on TTT operated within 5795 - 5815 MHz. May 2017.

4.3 MITIGATION TECHNIQUES TO ENABLE COEXISTENCE OF RLAN AND ROAD TOLLING (TTT)

The following approaches have been suggested in ECC Report 244 to enable the coexistence between RLAN and road tolling:

- Implementation in RLAN of a detection mechanism to detect road tolling applications – energy detection. The approach detailed in ANNEX 5 of ECC Report 244 can be applied for the determination of the detection threshold.
- Transmission from the road tolling applications of predefined signals (beacons) which indicate that the used channels are busy.
 - This would require additional equipment on the tolling gantry which could by itself cause interference with the tolling equipment. This is further explained in ETSI TR 103 319 [45].
- Ensuring the coexistence with road tolling systems through the detection of ITS. This is based on the assumption that there will always be ITS systems in the close vicinity of road tolling road-side units. Under this approach, once ITS has been detected by RLAN under the conditions described in Section 4.2, the road tolling frequency band 5795-5805/5805-5815 MHz will also be considered as occupied and thus, not available for RLAN use.
 - From the perspective of an in-car RLAN, the probability of being in the vicinity of another vehicle equipped with ITS will be (after the ITS roll-out in 2019) much higher than being in the vicinity of a tolling station.
- Use of geolocation database approach: the road tolling road-side units are generally fixed with a determined location. Information can be stored in a database and mechanisms may be developed so that this information may be used by RLAN to avoid interference.
 - ASECAP is preparing this central registry for European countries containing geographical locations of fixed and temporary TTT equipment (toll gantries, toll plazas etc.). It is not intended to reveal real-time data of mobile enforcement vehicles. The database is part of the mitigation mechanism between ITS and TTT according to EN 302 571 [38] and ETSI TS 102 792 [41]. The same dataset can be used for mitigation of interference into TTT from RLAN. A detection of TTT by RLAN could use the same locations given by the database, but use different protection radii. Also, the exact mitigation method could be different than ETSI TS 102 792 [41].
 - Manufacturers will have access to the database upon request and be able to download it and install in their equipment. This will allow the RLAN equipment to start mitigation procedures if it is close to a 5.8 GHz road tolling location.

4.3.1 Energy Detection requirements for the coexistence between RLAN and road tolling

The below considerations are based on the simplified approach in Annex A5.1 of ECC Report 244, where a formula is given to derive the threshold value for a LBT system.

First, the threshold values for RLAN as interferer are determined in Table 28 for an equal road tolling antenna gain on Rx and Tx side.

Table 28: Detection threshold, RLAN as interferer sensing road tolling victim, simplified approach (equal road tolling Rx and Tx antenna gain)

RLAN sensing road tolling					
		Victim / Wanted Transmitter (WT): Road tolling / TTT			
		BW-WT (MHz)	0.5	0.5	
		PWT (dBm)	33	33	
		Noise Fig. (dB)	2	2	
		Noise floor (dBm)	-115.01	-115.01	
		Margin (dB) (Note)	0	10	
		I/R (dB)	-6.00	-6.00	
Interfering Transmitter (IT): RLAN	BW-IT (MHz)	PIT in BW-IT (dBm)	PIT in BW-WT (dBm)	Pthr in BW-WT (dBm)	
	20	14	6.98	94.99	-84.99
	40	14	3.97	-91.98	-81.98
	80	14	0.96	-88.97	-78.97

PIT = Power of Interfering Transmitter, PWT = Power of Wanted Transmitter, Pthr = Power threshold

Note: Margin above sensitivity. Calculations are performed without margin (0 dB) and with a margin of 10 dB. For the calculation see ECC Rep. 244, Annex 5.1, equation 11.

The threshold values for RLAN as interferer for different road tolling antenna gain on Rx and Tx side are given in Table 29.

Table 29: Detection threshold, RLAN as interferer sensing road tolling victim, simplified approach (different road tolling Rx and Tx antenna gain)

RLAN sensing road tolling (different Tx and Rx gain)					
		Victim / Wanted Transmitter (WT): Road tolling / TTT			
		BW-WT (MHz)	0.5	0.5	
		PWT (dBm)	33	33	
		Tx gain- Rx gain dB (Gwt-Gvr)	-10	-10	
		Rx gain dBi	2.00	2.00	
		Noise floor (dBm)	-115.01	-115.01	
		Margin (dB) (Note)	0.00	10.00	
		I/R (dB)	-6.00	-6.00	
Interferer : RLAN	BW-IF (MHz)	PIT in BW-IT (dBm)	PIT in BW-WT (dBm)	Pthr in BW-WT (dBm)	
	20	14	6.98	-104.99	-94.99

RLAN sensing road tolling (different Tx and Rx gain)					
	40	14	3.97	-101.98	-91.98
	80	14	0.96	-98.97	-88.97

PIT = Power of Interfering Transmitter, PWT = Power of Wanted Transmitter, Pthr = Power threshold

Note: Margin above sensitivity. Calculations are performed without margin (0 dB) and with a margin of 10 dB. For the calculation see ECC Rep. 244, Annex 5.1, equation 11a.

The results show that for road tolling as victim working with 33 dBm in 0.5 MHz and at its sensitivity level, the LBT threshold values for RLAN to detect road tolling would be between -86 dBm and -95 dBm in 0.5 MHz dependent on the RLAN bandwidth; for the 20 MHz RLAN bandwidth, this is 18 dB above the noise floor of the receiver (N=-113 dBm in 0.5 MHz). For road tolling working with Tx power of 23 dBm (because of the antenna gain of the RSU of about 10 dBi), the threshold would be 10 dB lower as above but still more than 8 dB above the noise floor. If road tolling works with a certain margin above its sensitivity, then the threshold could be increased accordingly. The above results are given under the assumption of equal road tolling antenna gain on Rx and Tx side. For the case that the Tx antenna gain would be x dB lower than the Rx antenna gain of the road tolling station, the above threshold values would be x dB lower (e.g. with 5 dB lower Tx antenna gain compared to the Rx gain, the threshold values would be 5 dB lower).

Further consideration is required on the feasibility of detection thresholds of the order of -100 dBm/500 kHz and on their impact on the RLAN operation, together with the definition of the relevant protection criteria for road tolling, since low values of threshold are likely to trigger false detections.

Then the threshold values for road tolling as interferer are determined Table 30.

Table 30: Detection threshold, road tolling as interferer sensing a RLAN victim, simplified approach

Road tolling sensing RLAN					
		Victim / Wanted Transmitter (WT): RLAN			
		BW-WT (MHz)	20	20	
		PWT (dBm)	14	14	
		Noise Fig. (dB)	4.00	4.00	
		Noise floor (dBm)	-96.99	-96.99	
		Margin (dB) (Note)	0.00	10.00	
		I/R (dB)	-6.00	-6.00	
Interfering Transmitter (IT): TTT	BW1/MHz	Pit dBm/BW1	Pit dBm/BW2	Pthr dBm/BW2	
	1	23	19.99	-127.00	-117.00
	1	33	29.99	-137.00	-127.00

PIT = Power of Interfering Transmitter, PWT = Power of Wanted Transmitter, Pthr = Power threshold

Note: Margin above sensitivity. Calculations are performed without margin (0 dB) and with a margin of 10 dB. For the calculation see ECC Rep. 244, Annex 5.1, equation 11.

The results show that for RLAN as victim working with 14 dBm in 20 to 80 MHz at its sensitivity level, the LBT threshold values for road tolling to detect RLAN would be well below the noise floor of the receiver (more than 10 dB). If RLAN is working with a certain margin above its sensitivity, then the threshold could be increased accordingly.

It appears not feasible for road tolling to detect RLAN.

It has to be noted that time domain effects in regard to sensing procedures (e.g. listening time, dead time) are not considered in this section and maybe an issue for further work.

4.3.2 Transmission from the road tolling applications of predefined signals (beacons)

The concept foresees that a predefined signal (e.g. from a road-side road tolling station) transmits a trigger to the RLAN equipment to apply sensing mitigation techniques, similar to one of the mitigation techniques used to facilitate ITS and Road Tolling adjacent channel co-existence.

This approach should take into account that:

- Additional installations are needed to apply this procedure; beacon signals could interfere with the tolling equipment. A time synchronization is not always possible, especially in toll plazas where the TTT RSUs on the individual lanes are operating independently (cf. ETSI TR 103 319 56);
- The RLAN equipment should be capable of recognising beacons from these Road Tolling stations and applying appropriate mitigation procedures;
- A reprogramming of the RLAN chip (switching on/off RLAN/DSRC mitigation techniques) must be disabled. This would prevent users of tuning their equipment.

4.3.3 Geolocation database requirements for the coexistence between RLAN and road tolling

The usage of a geolocation database requires a central registry. ASECAP is preparing this central registry for European countries containing geographical locations of fixed and temporary TTT equipment (toll gantries, toll plazas etc.). It is not intended to reveal real-time data of mobile enforcement vehicles. The database is part of the mitigation mechanism between ITS and TTT according to EN 302 571 and ETSI TS 102 792. The same dataset can be used for mitigation of interference into TTT from RLAN. A detection of TTT by RLAN could use the same locations given by the database, but use different protection radii. Also, the exact mitigation method could be different than ETSI TS 102 792 [41].

Manufacturers will have access to the database upon request and be able to download it and install in their equipment. This will allow the RLAN equipment to start mitigation procedures if it is close to a 5.8 GHz road tolling location.

4.3.4 Summary

MCL calculations for both directions of interference have been performed and showed the need for significant separation distances if compatibility is dependent upon protection to an I/N level of -6 dB. No studies have been conducted to analyse the actual effects of this I/N level being reached due to intermittent interference.

Calculations also show that the tolling signal can be detected using the standard RLAN energy detection threshold of -62 dBm within a range that is larger than the tolling communication zone. However, the separation distance between a car with RLAN and a TTT RSU is even larger. Thus, RLAN in vehicles that have not yet detected the tolling signal can cause interference to the TTT RSU while there is another vehicle in the tolling zone. This has not been tested in field measurements. Further studies are needed to quantify this issue.

Lab and field measurements have been conducted in Spain and Germany. Lab tests have been carried out in a static setting. The detection of the TTT signal by RLAN equipment could be confirmed: Transmissions on RLAN channel 161, which is identical with the TTT band, are stopped when a TTT signal could be received. An impact on tolling transactions could be observed in the lab test and on a toll plaza test that were conducted with several repetitions: An increase in TTT transaction duration (a result of frame repetitions that could lead to errors under the time constraints of multi-lane free flow tolling) could be observed when RLAN is active on adjacent channels, especially if the RLAN output power is further increased beyond the 14dBm (25mW) limit of the SRD band. Field tests on a motorway showed that a RLAN connection is completely interrupted when passing through a tolling gantry. On the tolling side, the single vehicle test case showed no

significant impact on transaction performance. However, the motorway test was conducted with a single-vehicle, without repetitions and without variation of the equipment. Testing the two-vehicle scenario with a variety of equipment could be subject to further studies.

In summary, MCL calculations as well as lab and field test indicate that the RLAN detects the tolling signal and stops transmissions. However, the range of energy detection does not cover the separation distance. Thus, for RLAN in a car approaching a TTT installation, there is a pre-detection phase and a post-detection phase. In the pre-detection phase the TTT RSU is exposed to interference, which impacts TTT transactions of other cars, depending on the RLAN duty cycle. Regarding duty cycles it was concluded in ETSI TR 103 319 [45] that the tolerable duty cycle is so low that the road tolling frequencies are actually not useable for RLAN within the vicinity of the road toll stations. In the post-detection phase, RLAN stops transmitting with the consequence of throughput loss for a few seconds in multi-lane free flow tolling up to longer times depending on how long a vehicle stays in the vicinity of the TTT installation.

For further mitigation of the situation, some of the following approaches have been suggested to enable the coexistence between RLAN and road tolling in ECC Report 244 [24]. A comprehensive description of mitigation methods for RLAN and tolling along with an evaluation is given in ETSI TR 103 319 [45]. Some of them could be applied to the in-car situation considered in the present report:

- Implementation in RLAN of a detection mechanism to detect road tolling applications based on energy detection. Under the assumptions considered preliminary analysis indicated that for a RLAN system operating with 14 dBm/20 MHz a detection threshold of the order of -115 dBm/500 kHz would be required for a reliable detection of road tolling. Further consideration is required, including on the feasibility of such a detection threshold and its impact on the RLAN operation transmission from the road tolling applications of predefined signals (beacons) which indicate that the used channels are busy, similar to one of the mitigation techniques used to facilitate ITS and Road Tolling adjacent channel co-existence;
- Use of geolocation database approach. The geolocation database should hold actual information from static and, due to construction sites, temporary tolling installations. ASECAP is preparing this central registry for European countries containing geographical locations of fixed and temporary TTT equipment (toll gantries, toll plazas etc.). Manufacturers will have access to the database upon request and be able to download it and install in their equipment. The database could be used in RLAN equipment to start mitigation procedures if it is close to a 5.8 GHz road tolling location;
- The only 80 MHz channel within the SRD band, which is desired for use cases such as rear-seat entertainment, overlaps with the 20 MHz wide TTT band. There are two alternatives to using this 80 MHz channel (5735-5815 MHz): (A) using a 40 MHz channel outside the TTT band, at least for the time a vehicle is within a tolling zone. This, however, requires a reliable detection. The immediate switching towards a 40 MHz channel seems not supported by current equipment or by the current RLAN standard. It also increases the risk of adjacent band interference into tolling systems, and it reduces the throughput on the RLAN side. (B) use of 80 MHz channels at 5150-5250 MHz in an "in-vehicle mode" (as recently proposed by Germany⁶) with maximum output power of 20 mW e.i.r.p. in order to be comparable with the indoor limitation. Considerations on this proposal are, however, out of scope of the present report.

It has to be noted that time domain effects in regard to sensing procedures (e.g. listening time, dead time) or the effect of RLAN deployments on POD (Probability of Detection) and the associated aggregate interference environment have not yet been considered.

Further work is required to assess these approaches.

⁶ German contribution to CPG PT-D, September 2017. https://cept.org/Documents/cpg-pt-d/38075/ptd-17-105r1_studies-under-wrc-19-agenda-item-116-compliance-with-outdoor-limit-5-150-5-250-mhz

5 CONCLUSIONS

Use cases for WAS/RLAN in cars in the band 5725-5875 MHz under non-specific SRD regulation include smartphone links and rear-seat entertainment. These use cases require rather high bandwidths (80 MHz channels) over short distances, while the required output power in the order of 20mW is rather low.

Studies in this Report were based on MCL calculations, lab and field measurements as well as existing work. The investigations assume RLAN based on the IEEE 802.11 standard (max. 25 mW e.i.r.p.), road tolling (TTT) based on the CEN DSRC standards, and ITS based on the IEEE 802.11 standard. Single vehicle and two-vehicles scenarios have been considered: Experiments and MCL calculations for the single-vehicle case, only MCL calculations for the two-vehicles case. The effect of aggregate RLAN deployments in a number of cars and the associated aggregate interference environment has not been considered.

For the coexistence of ITS and WAS/RLAN in cars, the following results were achieved:

- MCL calculations for both directions of interference showed the need for significant separation distances, which cannot be achieved in realistic scenarios, especially if both systems are in the same vehicle;
- Coordinated channel access through Clear Channel Assessment of the IEEE 802.11 standard depends on the ability to mutually detect the preamble of the other application, which is currently not applicable, since IEEE 802.11 (conventional RLAN) uses 20 MHz and higher bandwidths, while ITS uses 10 MHz bandwidth;
- Time domain effects with regards to sensing procedures (e.g. listening time, avoidance time) have been initially studied in ETSI TR 103 319. It was found that it is important to distinguish between interference before ITS detection and interference after ITS detection. The mitigation methods described in ETSI TR 103 319, namely Detect&Vacate and Detect&Mitigate differ in post-detection-mitigation, where it is obvious that a Detect&Vacate eliminates interference from RLAN into ITS in the post-detection phase. For the pre-detection phase it was found that a modest amount of extra inter-packet spacing in the order of a few hundred microseconds already improves detection and helps to reduce the pre-detection interference;
- An automobile manufacturer that is in control of the RLAN and ITS deployment in its vehicles could choose a configuration where RLAN uses only channels outside the ITS band.

For the coexistence of road tolling (TTT) and WAS/RLAN in cars, the following results could be obtained:

- In the lab and field test under the considered scenarios, the effect of in-band interference could not be tested, since RLAN stopped transmitting or changed the channel in presence of the TTT signal. Lab tests conducted by the German Federal Network Agency⁷ show that without listen-before-talk, a 20 MHz signal at a power level of non-specific SRDs would lead to TTT transaction failures when the interfering signal bandwidth overlaps the TTT band;
- MCL calculations for both directions of interference showed the need for significant separation distances. These calculations as well as lab and field test indicate that RLAN can detect the TTT signal and stop transmissions. However, the range of energy detection does not cover the separation distance. Thus, for RLAN in a car approaching a TTT installation, there is a pre-detection phase and a post-detection phase. In the pre-detection phase the TTT RSU is exposed to interference, which impacts TTT transactions of other cars, depending on the RLAN duty cycle. However, ETSI TR 103 319 concludes that the tolerable duty cycle is so low that the road tolling frequencies are actually not useable for RLAN. In the post-detection phase, RLAN stops transmitting with the consequence of throughput loss as long as the vehicle is in the vicinity of the TTT installation;
- Lab and field measurements have been conducted in Spain and Germany. The detection of the TTT signal by RLAN equipment could be observed. An impact on tolling transactions could be observed in the lab test and on a toll plaza test. A slight increase in TTT transaction duration could be observed when RLAN is active on adjacent channels. Field tests on a motorway showed that an RLAN connection is

⁷ Doc. FM(17)100. Impact of radio applications, operated in the 5.8 GHz range, on TTT operated within 5795 - 5815 MHz. May 2017.

completely interrupted when passing through a tolling gantry. A two-vehicle scenario has not been tested;

- For further mitigation of the situation, mitigation methods have been suggested in ECC Report 244 [24] and assessed in ETSI TR 103 319 [45]. In addition, a high detection sensitivity by RLAN, a (temporary) use of a 40 MHz channel outside the TTT band, or an "in-vehicle mode" at 5150-5250 MHz with 20 mW e.i.r.p. could be considered.

ANNEX 1: PROPAGATION MODEL

The following propagation model with two breakpoints is used for MCL calculations:

$$PL = \begin{cases} 20 \log \left(\frac{\lambda}{4\pi d} \right) & d \leq d_0 \\ 20 \log \left(\frac{\lambda}{4\pi d_0} \right) - 10n_0 \log \left(\frac{d}{d_0} \right) & d_0 \leq d \leq d_1 \\ 20 \log \left(\frac{\lambda}{4\pi d_0} \right) - 10n_0 \log \left(\frac{d_1}{d_0} \right) - 10n_1 \log \left(\frac{d}{d_1} \right) & d > d_1 \end{cases}$$

Table 31: Propagation model

Propagation model		Urban	Suburban	Rural	ETSI TR 102 492
Breakpoint distance d0	M	64	128	256	15
Pathloss factor n ₀ beyond the first break point		3.8	3.3	2.8	2.7
Breakpoint distance d1	M	128	256	1024	1024
Pathloss factor n ₁ beyond the first break point		4.3	3.8	3.3	2.7

ANNEX 2: LIST OF REFERENCES

- [1] CEN EN 12253: "Road transport and traffic telematics - Dedicated short-range communication - Physical layer using microwave at 5,8 GHz", 2004
- [2] CEN EN 12795: "Road transport and traffic telematics - Dedicated Short Range Communication (DSRC) - DSRC data link layer: medium access and logical link control", 2003
- [3] CEN EN 12834: "Road transport and traffic telematics - Dedicated short-range communication - (DSRC) DSRC Application Layer", 2003
- [4] CEN EN 13372: "Road transport and traffic telematics (RTTT) - Dedicated short-range communication - Profiles for RTTT Applications", 2004
- [5] CEPT Report 20 Report from CEPT to EC in response to the Mandate on "Harmonised radio spectrum use for safety critical applications of ITS in the European Union", 2007
- [6] CEPT Report 57 Report A from CEPT to the European Commission in response to the Mandate "To study and identify harmonised compatibility and sharing conditions for Wireless Access Systems including Radio Local Area Networks in the bands 5350-5470 MHz and 5725-5925 MHz ('WAS/RLAN extension bands') for the provision of wireless broadband services", 2015
- [7] CEPT Report 64 Report B from CEPT to the European Commission in response to the Mandate "To study and identify harmonised compatibility and sharing conditions for Wireless Access Systems including Radio Local Area Networks in the bands 5350-5470 MHz and 5725-5925 MHz ('WAS/RLAN extension bands') for the provision of wireless broadband services", 2016
- [8] CEPT Report 59 In response to the EC Permanent Mandate on the "Annual update of the technical annex of the Commission Decision on the technical harmonisation of radio spectrum for use by short range devices", 2016
- [9] Commission Implementing Regulation 2016/799 of 18 March 2016 implementing Regulation (EU) No 165/2014 of the European Parliament and of the Council laying down the requirements for the construction, testing, installation, operation and repair of tachographs and their components
- [10] Directive 2004/52/EC of the European Parliament and of the Council of 29 April 2004 on the interoperability of electronic road toll systems in the Community, 29 April 2004.
- [11] Directive 2010/40/EU of the European Parliament and of the Council of 7 July 2010 on the framework for the deployment of Intelligent Transport Systems in the field of road transport and for interfaces with other modes of transport.
- [12] Directive 2014/53/EU of the European Parliament and of the Council of 16 April 2014 on the harmonisation of the laws of the Member States relating to the making available on the market of radio equipment and repealing Directive 1999/5/EC, 16 April 2014
- [13] Directive 2015/719/EU of the European Parliament and of the Council of 29 April 2015 amending Council Directive 96/53/EC laying down for certain road vehicles circulating within the Community the maximum authorised dimensions in national and international traffic and the maximum authorised weights in international traffic
- [14] EC Decision 2005/513/EC complemented by EC Decision 2007/90/EC
- [15] EC Decision 2008/671/EC: "Commission Decision of 5 August 2008 on the harmonised use of radio spectrum in the 5875-5905 MHz frequency band for safety related applications of Intelligent Transport Systems (ITS)"
- [16] ECC Decision (04)08: "Harmonised use of 5 GHz for the implementation of WAS/RLANs", 2009
- [17] ECC Decision (08)01: "ECC Decision of 14 March 2008 on the harmonised use of the 5875-5925 MHz frequency band for Intelligent Transport Systems (ITS)", 2015
- [18] ECC Decision (15)03: "The harmonised use of broadband DA2GC systems in the frequency band 5855-5875 MHz", 2015
- [19] ECC Recommendation (06)04: "Use of the band 5725-5875 MHz for Broadband Fixed Wireless Access (BFWA)", 2006
- [20] ECC Recommendation (08)01: "Use of the band 5855-5875 MHz for Intelligent Transport Systems", 2015
- [21] ECC Recommendation (17)03: "Guidance for the harmonised use and coordination of Maritime Broadband Radio (MBR) systems on board ships and off-shore platforms operating within the frequency bands 5852-5872 MHz and 5880-5900 MHz", 2017
- [22] ECC Report 101: "Compatibility studies in the band 5855– 5925 MHz between Intelligent Transport Systems (ITS) and other systems", 2007
- [23] ECC Report 228: "Compatibility Studies between the Intelligent Transport Systems (ITS) in the Band 5 855 MHz to 5 925 MHz and other systems in adjacent bands", 2015
- [24] ECC Report 244: "Compatibility studies related to RLANs in the 5725-5925 MHz band", January 2016

- [25] ECC Report 250: "Compatibility studies between TTT/DSRC in the band 5805-5815 MHz and other systems", April 2016
- [26] ERC/REC 70-03: "Relating to the use of Short Range Devices (SRD)" version from May 2017
- [27] ERC/REC 74-01: "Unwanted emissions in the spurious domain", January 2011
- [28] ERC Report 25: "The European Table of Frequency Allocations and Applications in the Frequency Range 8.3 KHz To 3000 GHz (ECA Table)"
- [29] ETSI EN 300 440-2 V1.4.1: "Electromagnetic compatibility and Radio spectrum Matters (ERM); Short range devices; Radio equipment to be used in the 1 GHz to 40 GHz frequency range; Part 2: Harmonized EN covering the essential requirements of article 3.2 of the R&TTE Directive", August 2010
- [30] ETSI EN 300 674-1 V1.2.1: "Electromagnetic compatibility and Radio spectrum Matters (ERM); Road Transport and Traffic Telematics (RTTT); Dedicated Short Range Communication (DSRC) transmission equipment (500 kbit/s / 250 kbit/s) operating in the 5,8 GHz Industrial, Scientific and Medical (ISM) band; Part 1: General characteristics and test methods for Road Side Units (RSU) and On-Board Units (OBU)", August 2004
- [31] ETSI EN 300 674-2-1 V2.1.1: "Transport and Traffic Telematics (TTT); Dedicated Short Range Communication (DSRC) transmission equipment (500 kbit/s / 250 kbit/s) operating in the 5 795 MHz to 5 815 MHz frequency band; Part 2: Harmonised Standard covering the essential requirements of article 3.2 of the Directive 2014/53/EU; Sub-part 1: Road Side Units (RSU)", September 2016
- [32] ETSI EN 300 674-2-2 V2.1.1: "Transport and Traffic Telematics (TTT); Dedicated Short Range Communication (DSRC) transmission equipment (500 kbit/s / 250 kbit/s) operating in the 5 795 MHz to 5 815 MHz frequency band; Part 2: Harmonised Standard covering the essential requirements of article 3.2 of Directive 2014/53/EU; Sub-part 2: On-Board Units (OBU)", November 2016
- [33] ETSI EN 301 443 V2.1.1: "Satellite Earth Stations and Systems (SES); Harmonised Standard for Very Small Aperture Terminal (VSAT); Transmit-only, transmit-and-receive, receive-only satellite earth stations operating in the 4 GHz and 6 GHz frequency bands covering the essential requirements of article 3.2 of the Directive 2014/53/EU", May 2016
- [34] ETSI EN 301 783 V2.1.1: "Commercially available amateur radio equipment; Harmonised Standard covering the essential requirements of article 3.2 of the Directive 2014/53/EU", January 2016
- [35] ETSI EN 301 893 V2.1.1 : "5 GHz RLAN; Harmonised Standard covering the essential requirements of article 3.2 of Directive 2014/53/EU", May 2017
- [36] ETSI EN 302 372 V2.1.1: "Short Range Devices (SRD); Tank Level Probing Radar (TLPR) equipment operating in the frequency ranges 4,5 GHz to 7 GHz, 8,5 GHz to 10,6 GHz, 24,05 GHz to 27 GHz, 57 GHz to 64 GHz, 75 GHz to 85 GHz; Harmonised Standard covering the essential requirements of article 3.2 of the Directive 2014/53/EU", December 2016
- [37] ETSI EN 302 502 V2.1.1: "Wireless Access Systems (WAS); 5,8 GHz fixed broadband data transmitting systems; Harmonised Standard covering the essential requirements of article 3.2 of Directive 2014/53/EU", March 2017
- [38] ETSI EN 302 571 V2.1.1: "Intelligent Transport Systems (ITS); Radiocommunications equipment operating in the 5 855 MHz to 5 925 MHz frequency band; Harmonised Standard covering the essential requirements of article 3.2 of Directive 2014/53/EU", February 2017
- [39] ETSI EN 302 663 V1.2.1: "Intelligent Transport Systems (ITS); Access layer specification for Intelligent Transport Systems operating in the 5 GHz frequency band", July 2013
- [40] ETSI EN 303 276 V1.1.1 2Maritime Broadband Radiolink operating within the bands 5 852 MHz to 5 872 MHz and/or 5 880 MHz to 5 900 MHz for ships and off-shore installations engaged in coordinated activities; Harmonised Standard covering the essential requirements of article 3.2 of Directive 2014/53/EU", November 2017
- [41] ETSI TS 102 792 V1.2.1: "Intelligent Transport Systems (ITS); Mitigation techniques to avoid interference between European CEN Dedicated Short Range Communication (CEN DSRC) equipment and Intelligent Transport Systems (ITS) operating in the 5 GHz frequency range", June 2015
- [42] ETSI TS 136 141 V14.5.0 : "LTE; Evolved Universal Terrestrial Radio Access (E-UTRA); Base Station (BS) conformance testing (3GPP TS 36.141 version 14.5.0 Release 14)", October 2017
- [43] ETSI TR 102 654 V1.1.1: "Electromagnetic compatibility and Radio spectrum Matters (ERM); Road Transport and Traffic Telematics (RTTT); Co-location and Co-existence Considerations regarding Dedicated Short Range Communication (DSRC) transmission equipment and Intelligent Transport Systems (ITS) operating in the 5 GHz frequency range and other potential sources of interference", January 2009
- [44] ETSI TR 102 960 V1.1.1: "Intelligent Transport Systems (ITS); Mitigation techniques to avoid interference between European CEN Dedicated Short Range Communication (RTTT DSRC) equipment and Intelligent Transport Systems (ITS) operating in the 5 GHz frequency range; Evaluation of mitigation methods and techniques", November 2012

- [45] ETSI TR 103 319 V1.1.1 "Broadband Radio Access Networks (BRAN); 5 GHz high performance RLAN; Mitigation techniques to enable sharing between RLANs and Road Tolling and Intelligent Transport Systems in the 5 725 MHz to 5 925 MHz band", August 2017
- [46] Explanatory paper related to RLAN equipment using the 5 GHz bands in vehicles, including the usage under the non-specific SRD regulation. <http://www.efis.dk/documents/44659>, February 2017
- [47] Geissler et al.: "Field Study on the Performance of Wireless Local Area Networks in Automotive Environments, Wireless Congress 2016: Systems & Applications", 2016.
- [48] IEEE 1609:"Family of Standards for Wireless Access in Vehicular Environments (WAVE). ITS Standards Fact sheet" <https://www.standards.its.dot.gov/Factsheets/Factsheet/80>
- [49] IEEE Std. 802.11™-2016: "IEEE Standard for Information Technology - Telecommunications and information exchange between systems - Local and metropolitan area networks - Specific requirements. Part 11: Wireless LAN Medium Access Control (MAC) and Physical Layer (PHY) Specifications"
- [50] M/453 Standardisation Mandate addressed to CEN, CENELEC and ETSI in the field of Information and Communication Technologies to support the Interoperability of Co-operative Systems for Intelligent Transport in the European Community", June 2009
- [51] Recommendation ITU-R F.1336-3: "Reference radiation patterns of omnidirectional, sectoral and other antennas in point-to-multipoint systems for use in sharing studies in the frequency range from 1 GHz to about 70 GHz", March 2012
- [52] Recommendation ITU-R F.1399-1: "Vocabulary of terms for wireless access"
- [53] Recommendation ITU-R M.1739 "Protection criteria for wireless access systems, including radio local area networks, operating in the mobile service in accordance with Resolution 229 (WRC-03) in the bands 5 150-5 250 MHz, 5 250-5 350 MHz and 5 470-5 725 MHz", March 2006
- [54] Recommendation ITU-R SM.329-12: "Unwanted emissions in the spurious domain", September 2012
- [55] Transportation Research Board: "Highway Capacity Manual", ISBN 0-309-06681-6, 2016