



ECC Report 238

3rd Party Access to Number Portability Data (NP Data)

Approved 29 October 2015

EXECUTIVE SUMMARY

Number Portability (NP) has proven to be a key competition enabler since market liberalisation by allowing end-users to retain their numbers while switching from one service provider to another. NP obligations are enshrined in the European Regulatory Framework and national NP Central Reference Databases (CRDB) were originally established to facilitate providers of services and operators of networks, both fixed and mobile, to meet their respective obligations.

In recent years, evolving technology and service innovation, including the emergence of cloud services, has facilitated new and interesting business models for the provision of electronic communications services. NRAs in many CEPT countries have been approached by market actors who believe that they have legitimate reasons for accessing the NP Data. This type of 3rd party access is seen by many organisations as necessary to drive industry innovation which may lead to greater cost efficiency through more efficient traffic routing. For the purposes of this Report, 3rd party access is defined as access to NP Data by entities other than those who have obligations to implement NP at the national level for the sole purposes of implementing more efficient routing and increasing tariff transparency.

The information contained in NP CRDB may also be important for end-users who are price sensitive about the calls that they make. In the past, end-users were able to determine, by the leading digits of the number, the identity of the terminating network or service provider and the anticipated cost of making a call. Since the introduction of NP end-users may no longer be able to rely on the leading digits of the number to determine call costs thus lowering tariff transparency and increasing the possibility of unexpected call charges.

It is important to be clear from the outset that these 3rd parties require access to determine the terminating operator associated with a number to enable more efficient routing or to increase tariff transparency and the scope of the Report does not extend beyond that. Access to other confidential, personal or commercially sensitive information that may be contained in the national database is outside the scope of the Report. Access to NP Data by NRAs, judicial authorities, operators of emergency services or other relevant authorities for regulatory or legal purposes is also outside the scope of the Report.

In order to promote more efficient routing and preserve tariff transparency, the Report analyses the associated issues with providing access to the NP Data contained in national NP CRDB by 3rd parties with a justifiable need for access and to identify policy options to address that need.

The Report examines the changes that have taken place in call routing practices since the introduction of NP and concludes that the routing information contained therein is becoming increasingly important for many different stakeholders.

Chapter 2 identifies the benefits and the technical challenges associated with NP implementation in the national networks.

Chapter 3 identifies several different types of 3rd party access seekers and examines their need for NP Data.

Chapter 4 considers current access policies in those CEPT countries that have already provided access for 3rd parties to NP Data. The different governance arrangements for the management of NP systems are also discussed.

Chapter 5 focuses on the terms and conditions of 3rd party access and examines issues such as data ownership, intellectual property rights, terms of use for commercial access and end-user access, privacy issues, jurisdiction and monitoring. This chapter considers also how compliance monitoring and enforcement could be implemented to deter 3rd party access seekers from using or reselling NP Data for purposes other than specified in the terms and conditions of access.

Chapter 6 details the conclusions drawn in the report which are:

- Access to national NP Data should be provided to 3rd parties for the purposes of implementing more efficient routing and/or to increase tariff transparency.
- For commercial users who plan to use NP Data to implement more efficient routing, access to this data should be based on a contract with the entity, or one of the entities, responsible for the administration of the NP Data. If fees are imposed for 3rd party access they should be based on a cost recovery model.
- For end-users access should be offered in an easily accessible format and free of charge to promote tariff transparency and fulfil informational needs.
- NP Data should not be used by 3rd parties for sales, marketing, promotional or other commercial activities or resold to any other entity.

TABLE OF CONTENTS

1	INTRODUCTION.....	8
2	NUMBER PORTABILITY – THE BENEFITS AND THE TECHNICAL CHALLENGES	10
2.1	A key competition enabler	10
2.2	Issues Introduced by Number Portability and the value of routing information.....	11
2.2.1	Routing of calls and messages.....	11
2.2.2	Erosion of tariff transparency.....	11
3	THE NEED FOR ACCESS TO NP DATA BY 3RD PARTIES	12
3.1	Access for informational purposes	12
3.2	Access for routing purposes.....	12
3.2.1	By international carriers.....	12
3.2.2	By specialised NP clearing houses	12
3.2.3	By SMS Service Providers (SMS-SP)	13
3.2.4	VoIP service providers.....	14
3.2.5	Access by commercial entities for outbound calling.....	15
4	CURRENT ACCESS POLICIES.....	16
4.1	Access policies for informational purposes	16
4.2	Access policies for routing purposes.....	16
5	CONDITIONS AND TERMS OF USE OF 3RD PARTY DATA.....	17
5.1	Ownership of the data and intellectual property rights	17
5.1.1	Intellectual Property Rights (IPR) Related to the NP database.....	17
5.1.2	Ownership of NP Data	17
5.1.3	Nature of the Data	17
5.2	Commercial Access – Conditions and terms of use.....	18
5.2.1	Access on a cost recovery basis	18
5.2.2	Access based on contract	18
5.2.3	The use of NP Data	18
5.3	End-user Access – Conditions and terms of use	18
5.3.1	The use of NP Data	18
5.3.2	Access free of charge.....	19
5.4	Other issues related to getting access	19
5.4.1	Privacy issues.....	19
5.4.2	Jurisdiction.....	19
5.4.3	Monitoring compliance and enforcing regulations around the use of NP Data	19
6	CONCLUSIONS.....	20
	ANNEX 1: ROUTING OF TRAFFIC BEFORE AND AFTER NP IMPLEMENTATION	21
	ANNEX 2: DIFFERENT IMPLEMENTATIONS OF NUMBER PORTABILITY.....	24
	ANNEX 3: COUNTRY-SPECIFIC EXAMPLES OF DECENTRALISED NP DB IMPLEMENTATION.....	29

LIST OF ABBREVIATIONS

Abbreviation	Explanation
ACQ	All Call Query
BEREC	Body of European Regulators for Electronic Communications
CEPT	European Conference of Postal and Telecommunications Administrations
COCOM	Communications Committee (from the EC)
DB	Database
DAE	Digital Agenda for Europe
E.164	ITU-T Recommendation E.164
EC	European Commission
ECC	Electronic Communications Committee
ECN	Electronic Communications Network
ENUM	E.164 Number Mapping
EU	European Union
FNO	Fixed Network Operator
FNP	Fixed NP
FTR	Fixed Termination Rate
IP	Internet Protocol
LCR	Least-Cost Routing
MCC	Mobile Country Code
MNC	Mobile Network Code
MNO	Mobile Network Operator
MNP	Mobile NP
MTR	Mobile Termination Rate
MVNO	Mobile Virtual Network Operator
NP	Number Portability
NP CRDB	NP Central Reference Database
NP DB (Adm)	Administrative NP DB
NP (Op)	Operational NP DB
NRA	National Regulatory Authority
OTT	Over The Top
PBX	Private Branch Exchange
PSTN	Public Switched Telephone Network
QoR	Query on Release
RCS	Rich Communications Service
RN	Routing Number (as defined in ETSI TR 101 122). May also be referred to as a Service Provider Routing Number (SPRN), NP Routing Code or Network Routing Number (NRN).
SCP	Service Control Point
SMS	Short Message Service
SMS-SP	SMS Service Provider
SPAM	Irrelevant or unsolicited messages sent over the Internet

SPIT	SPAM over Internet telephony
SSP	Service Switching Point
VoIP	Voice over IP
WG NaN	Working Group Numbering and Networks
Wi-Fi	Wireless local area network

DEFINITION OF TERMS

3 rd Party Access	Access to NP Data by entities other than those who have obligations to implement Number Portability at the national level for the sole purposes of implementing more efficient routing and increasing tariff transparency
All Call Query (ACQ)	In this routing method, the origination network, prior to route the call, queries the NP DB (Op) in order to find if the number is ported and if this is the case, it will add a Routing Number (RN) to route the call to the recipient network.
Donor Network	Donor Network is the initial network where a number was assigned by the NRA before ever being ported.
Least-cost routing	Least-cost routing is the process of selecting the path of outbound communications traffic based on cost.
NP Data	Numbers and their associated service provider identifiers as they are stored in and retrieved from the NP CRDB or NP DB (Adm). These data could be provided in a format which requires further processing in order to render routing information.
Off-net	Off-net calls are calls to other networks than where it is originated.
On-net	On-net calls are calls inside the same network.
Originating Network	Originating Network is the network where the calling party is connected.
Recipient Network	Recipient Network is the Network where a number is located after being ported.
Routing Information	In the context of this Report it is the information that enables the identification of the service provider associated with a ported number.
SMS – Aggregator/Service Provider	An intermediary between wireless carriers and application service providers or a business (shops, banks) providing bulk SMS to its customers.
NP CRDB	Centralised database where all information related to ported numbers is available (ported number with associated routing numbers and flows of the porting processes).
Administrative NP DB (NP DB (Adm))	Network element that interacts with the NP CRDB and is involved in the NP processes and updates the real time NP DB (Op)
Operational NP DB (NP DB (Op))	Network element where all ported numbers associated with the routing numbers are available. It is this network element that is queried during call setup.

1 INTRODUCTION

Before the introduction of Number Portability (NP) the service provider responsible for terminating a call to a number was always the one to whom the associated numbering range¹ was assigned by the NRA. The original assignee of a numbering range may no longer be the one responsible for the origination and termination of traffic to and from a number as the service, after the number has been ported, may be provided by an alternative service provider. Therefore the inherent link that existed between an individual number and the service provider or network operator to whom the associated numbering range was originally assigned has been eroded.

While the consumer and competition benefits of NP are obvious, it presents more complex routing challenges and additional costs for service provider or network operators, SMS aggregators and other application service providers, both nationally and internationally, to route calls or messages optimally using the leading digits of the called number. In order to have more efficient routing, the NP data needs to be made available to these types of service providers.

NP solutions architectures vary from country to country and so too do the governance arrangements covering implementation, maintenance and access. These solutions are typically based on a database which associates a routing number, or equivalent information about the recipient, to each ported number. This database may be centralised or distributed². These unique numbers identify all terminating service providers associated with all numbers that have been ported. Upon interrogation of the database, originating service providers are able to determine the most efficient way to route and terminate a call. As the volume of ported numbers continues to increase, the NP Data becomes an increasingly critical resource for all industry stakeholders.

As technology and service innovation continues to evolve, entities other than mobile and fixed service providers and network operators are now seeking access to the NP Data contained in the NP CRDB e. g. in order to implement more efficient routing. The NP Data associated with ported numbers is important to service providers but it may also be important to end-users who are price sensitive about the calls that they make. In the past, end-users were able to determine, by the leading digits of the number, the identity of the terminating network or service provider and the anticipated cost of making the call.

Since the introduction of NP end-users may no longer rely on the leading digits of the number to determine call costs thus lowering tariff transparency and increasing the possibility of unexpected call charges. The issue of tariff transparency in the context of Mobile NP is noted in Recital 41 of the Universal Services Directive³ which provides *inter-alia* that NRAs should, “*where feasible, facilitate appropriate tariff transparency as part of the implementation of number portability*”.

This problem occurs, in the case of some subscriptions, where the price difference between on-net and off-net calls, mainly in mobile networks, varies greatly and the identification of the respective service provider is no longer possible. Various solutions have been implemented to resolve this problem. In some countries an audible beep or an announcement is played to inform the caller that the call is going off-net. In other countries, a service number is provided that customers can call to determine the terminating network of a particular number.

This may not remain a problem in the longer term as mobile termination rates are declining, Figure 1 below presents the situation in recent years in Europe:

¹ In this document the term “associated numbering range” refers to the original numbering range from which a number was first assigned.

² For the purposes of this document a solution based on a CRDB is referred to even if the same principles apply to the distributed solution.

³ <http://eur-lex.europa.eu/legal-content/EN/ALL/?uri=CELEX:32002L0022>

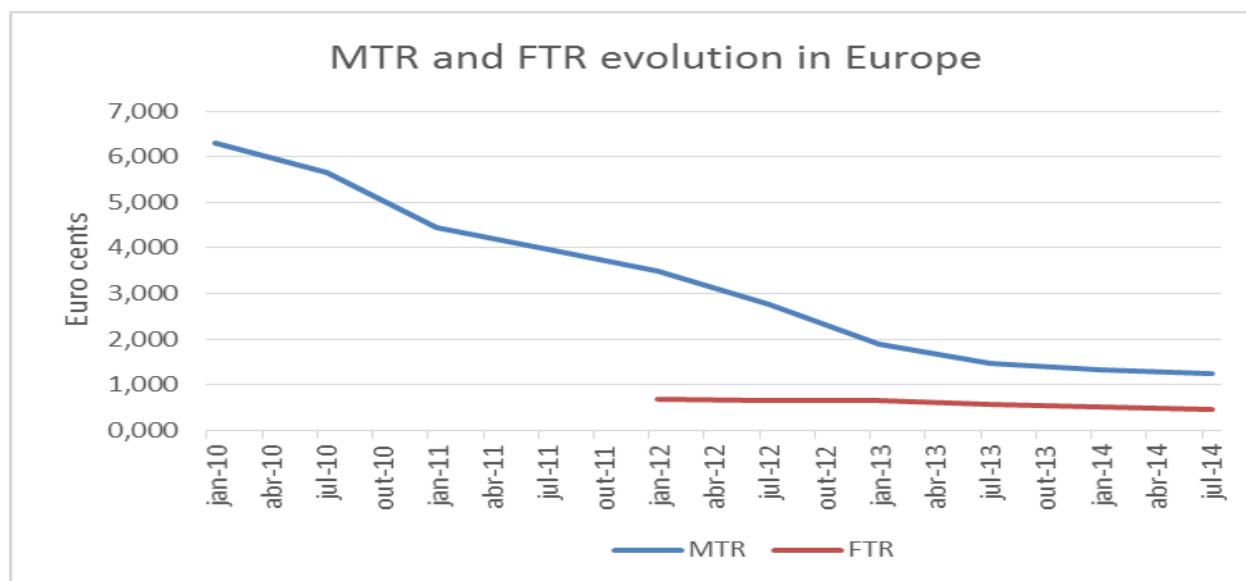

Figure 1: Comparison of reduction in MTRs versus FTRs in Europe 2010-2014
(Source: based on BEREC's Benchmark snapshots)

This reduction in MTRs may facilitate broadly similar retail pricing between on-net and off-net calls and the introduction of more competitive flat rate subscriptions in the future.

As the volume of ported numbers increases it is expected that an ever-increasing proportion of international voice traffic and especially international messaging traffic may no longer be routed in the most efficient way. This will inevitably lead to higher costs at the wholesale level and, consequently, at the retail level.

In order to promote more efficient routing of calls and messages and to preserve tariff transparency, this Report analyses the associated issues with providing access to the NP data by 3rd parties with a justifiable need for access and it aims to identify policy options to address that need.

The Report attempts to identify those stakeholders who do not have access to NP data because they do not have NP obligations. These may include end-users, SMS aggregators, transit operators, companies with large PBXs, banks, social media providers etc. The Report also investigates if, and under what terms, 3rd party access should be granted.

It is important to be clear from the outset that these 3rd parties require access to determine the terminating operator associated with a number to enable more efficient routing or to increase tariff transparency and the scope of this Report does not extend beyond that. Access to other confidential, personal or commercially sensitive information that may be contained in the NP Data is outside the scope of this report. Access to NP Data by NRAs, judicial authorities, operators of emergency services or other relevant authorities for regulatory or legal purposes is also outside the scope of this Report.

2 NUMBER PORTABILITY – THE BENEFITS AND THE TECHNICAL CHALLENGES

2.1 A KEY COMPETITION ENABLER

NP is a crucial component in a competitive market. Prior to the introduction of NP subscribers were required to give up their numbers if they wanted to switch service providers. NP has now enabled subscribers to retain their numbers while switching between different service providers with a minimum level of disruption and has become a key competition enabler by helping to break the dominance of incumbent market players while providing opportunities for new market entrants and choice and value for consumers.

The following graph (Figure 2), from the Digital Agenda Scorecard 2013, illustrates the positive impact NP has made on the mobile market over the last 8-10 years.

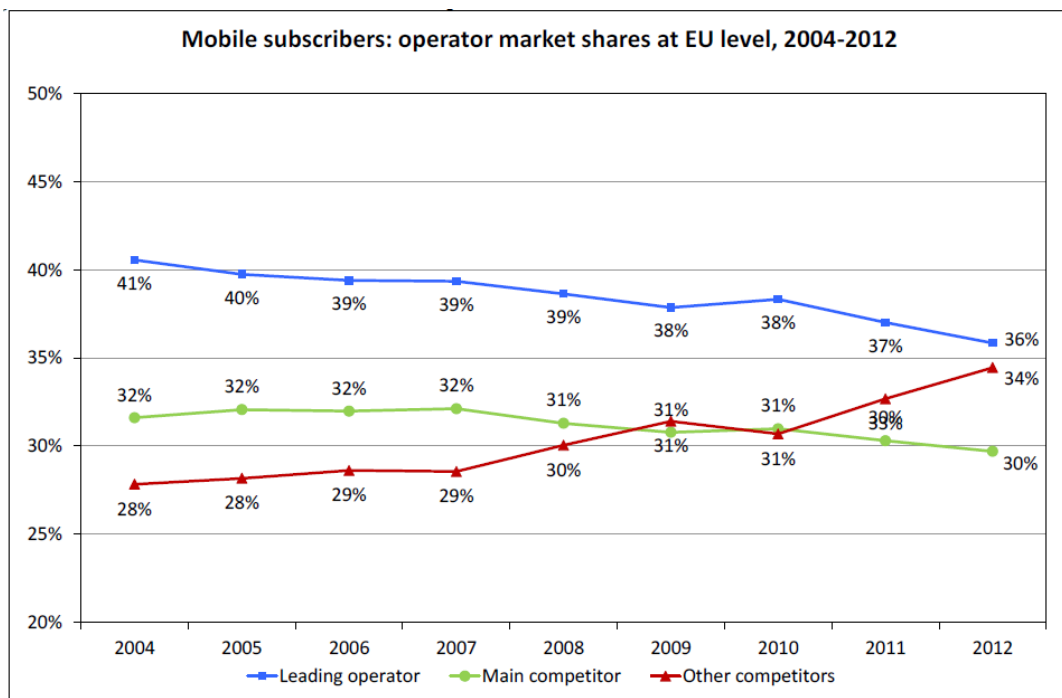

Figure 2: Mobile subscribers: operator market shares at EU level, 2004-2012
 (Source: COCOM, taken from DAE Scorecard Report 2013)

Mobile NP is most popular in Denmark, Italy and France, where 8-12% of numbers were ported in the first three quarters of 2012⁴. As Member States of the EU strive to meet the targets for faster porting⁵ of a number it is likely that competition will intensify as the number of ports increases. Furthermore, the number of ports between providers of services at a fixed location is also likely to increase significantly as the rollout of next generation networks accelerates.

⁴ DAE Report Scorecard 2013 - <https://ec.europa.eu/digital-agenda/sites/digital-agenda/files/DAE%20SCOREBOARD%202013%20-%20SWD%202013%20217%20FINAL.pdf>

⁵ Article 30, Section 4 of Directive 2002/22/EC as amended by 2009/136/EC.

2.2 ISSUES INTRODUCED BY NUMBER PORTABILITY AND THE VALUE OF ROUTING INFORMATION

The benefits to consumers and to competition in general since the implementation of NP are clear, but it has also introduced two main issues described in the following sub-sections.

2.2.1 Routing of calls and messages

The first of these is in relation to routing calls and messages. An originating operator can no longer rely on analysing the called number to identify the terminating operator to which the call or message should be routed to. This issue is partly solved by the use of routing numbers. These routing numbers are associated to the number by the originating operator, after the NP DB is interrogated, and the call or message is routed appropriately. Access to the NP Data is essential for this solution to work and in some countries smaller operators and/or SMS providers may not have access to this valuable data, especially if they don't have NP obligations or if the NP Data is administered by a group of operators.

2.2.2 Erosion of tariff transparency

The second issue is the erosion of the inherent tariff transparency associated with a number. Before NP it was possible for a caller to reasonably determine the expected call cost for dialling a particular number based on the leading digits of the number. This is mainly a problem for mobile callers where a caller's subscription may allow for a certain number of free calls to customers on the same network. With NP, it is no longer possible for the user to determine which network a subscriber is on (i.e. on-net or off-net) by analysing the significant digits of a telephone number. This was a reason for the implementation in some countries of a warning (beep or announcement) during the call to inform the calling user that the dialled number had changed service provider. In other countries subscribers can call a number to get information about the network or the service provider associated with a ported number.

The problem also exists in the case of international calls and messages if there are differences in the termination rates depending on the service provider, ported numbers will have a higher rate compared with the non-ported numbers. For SMS providers this problem is more significant, because for ported numbers a transit rate is normally added to the standard termination rate for SMS.

Also for big enterprises with PBXs that perform least cost routing, the NP Data could be important, especially in connection with calls to mobile numbers.

The two issues described above highlight cases where access to NP Data is required not only by service providers and network operators, but also by many different types of 3rd parties.

3 THE NEED FOR ACCESS TO NP DATA BY 3RD PARTIES

The national numbering plan with its allocations and assignments can be considered as a public resource. In this light, access to NP Data should only be given where the need is justified and on a non-discriminatory and transparent basis.

This chapter describes the needs of the various 3rd parties to access NP Data. Access to NP Data should only be for informational purposes and/or the efficient routing of calls and messages. For a detailed description of the various access methods see Annex 2 (Section A2.2).

3.1 ACCESS FOR INFORMATIONAL PURPOSES

Since the introduction of NP, end-users can no longer rely on the information contained in the leading digits (the first two or three digits) of the E.164 number to determine if a call is on-net or off-net. This may have a negative impact on tariff transparency particularly for price-sensitive end-users. In cases where fixed price packages are prevalent or where there is little or no difference between on-net and off-net calls, the weight of this as an argument for NP access is not high.

In some cases end-users have an interest in identifying the operator that serves a specific number, e.g. in cases of misuse of premium rate numbers, in case of complaints, nuisance calls, or in cases of suspicion of identity theft. This information may be needed to identify the person or company (e.g. a content provider) originating the call. In the case of premium rate numbers, further information, which is not derived from NP data, may be necessary in order to resolve misuse or complaints. Access to such further information is outside of the scope of this Report.

In principle, there are no legal restrictions or data protection issues in order to give end-users information on the service provider associated with a ported number. The NP Data need only be sufficient to determine the service provider of a ported number.

3.2 ACCESS FOR ROUTING PURPOSES

3.2.1 By international carriers

The need for national operators to access NP Data is evident as it enables them to meet their NP obligations and facilitates all-to-all communication and the efficient routing of traffic. Due to the fact that international carriers do not have NP obligations outside of their home country they do not normally have access to NP Data in other countries even if they have an interest in accessing this NP Data in order to minimise international transit costs.

Long distance calls and messages are normally “onward routed” when they arrive at the incoming international gateway switch of a destination country. The national operator receiving the call or message then performs a query to the NP DB and routes the call or message to the correct terminating national service provider.

The most up to date set of NP Data could be made available to international carriers to route these calls and messages more efficiently.

3.2.2 By specialised NP clearing houses

To provide a more efficient means of routing international calls and messages, specialised NP clearing houses have been established. These clearing houses negotiate access to NP Data in multiple countries and then provide the routing information derived from that NP Data as a service. The advantage of this approach is that the clearing house assumes the burden of negotiating access and then provides a one stop shop for originating operators to obtain routing information for multiple countries. The routing of calls using the clearing house solution is illustrated in Figure 3 below:

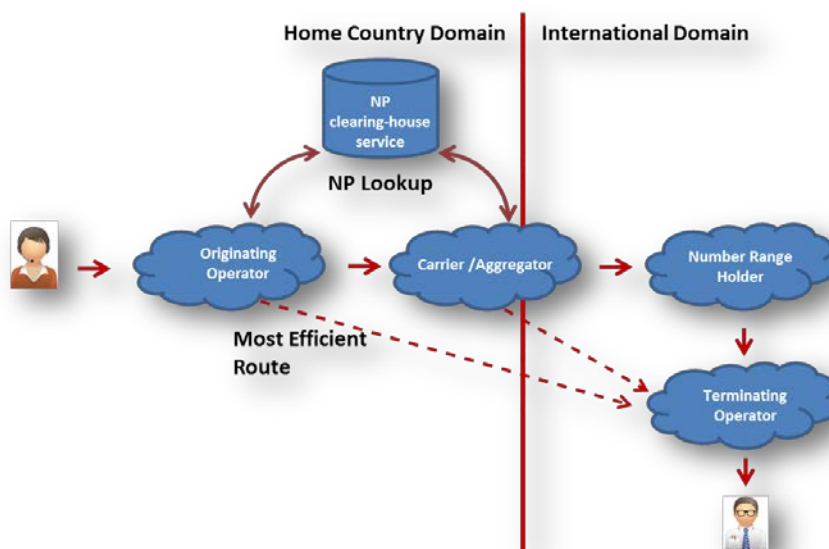

Figure 3: Purpose and functioning of clearing house solution

A specialized NP clearing house can centralise the service logic of a new service to one country which is offered to its customers in multiple countries, and requires access to NP data both to route its own subscriber services, and to route outbound calls efficiently to the optimum break out location. NP data is required outside the home country to allow the remote service to be provided at lower cost to users within the home network.

3.2.3 By SMS Service Providers (SMS-SP)

SMS-SPs provide SMS traffic for termination towards a mobile end-user via a “signalling service provider”. These types of services allow end-users to send and receive SMS independently of their mobile subscription over a data (IP) connection which can be carried over Wi-Fi or mobile internet. Typical applications include the sending and receiving of SMS from connected devices (e.g. PC or smartphone) or providing bulk SMS from a business to its customers. Some versions of the service may be national-only, but most SMS-SPs offer services across borders.

SMS-SPs may be considered to have the right to access the NP Data in some countries, but in others not. Access to NP Data is very important for SMS-SPs in order to optimise routing and to minimise the termination costs of reaching the destination number by excluding the transit element of the cost.

While SMS is a well-established technology, its use as a pure messaging platform has declined for person-to-person communication with the advent of Social Media and OTT services such as WhatsApp, Viber and Skype. However, its use as an authentication tool is growing. Examples of this type of use include:

- **Internet payments:** When you purchase goods or services online, many credit card providers have started to use an additional authentication tool to just providing the card number, expiry date and the security code. This works by sending an SMS with a unique code to the number associated with the credit card. When the end-user receives the message the code must be inserted in order to complete the online transaction.
- **High security password resetting:** Companies, such as Google, now offer a more secure way of resetting your account password by sending a unique code to the number associated with the account. This code can then be used to authenticate the use and the password can then be reset.
- **Online banking:** Some banks now require you to insert a unique code along with your username and password to access online banking. This unique code is also sent to the number associated with the account.

These types of applications are generating a significant volume of new SMS traffic and the companies and service providers behind these services are keen to route these messages as efficiently as possible in order to keep costs down. These cost reductions can be achieved by having access to NP Data.

3.2.4 VoIP service providers

VoIP service providers, who use the Internet as their backbone network, operate in an environment without national boundaries. They are essentially global operators that do not typically have access to NP Data for calls that need to be terminated on the PSTN. Allowing VoIP service providers to have access to the most up to date NP Data would facilitate more efficient and cost effective call routing as the Internet backbone could be used to route the call as close as possible to the called party and breakout to the PSTN would only happen at the local level. This is illustrated in Figure 4 below:

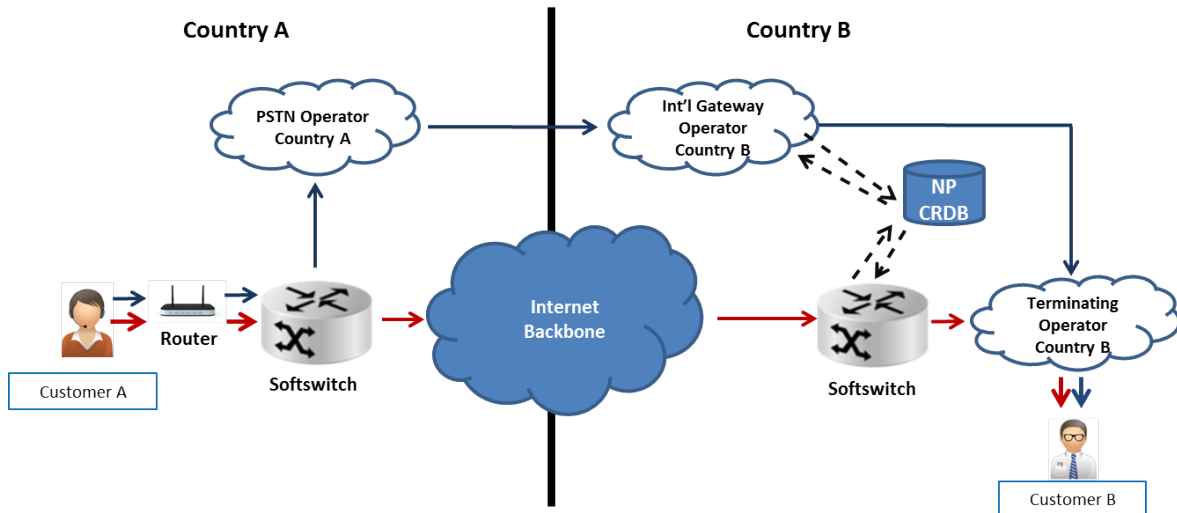

- ➔ **PSTN breakout at originating side:** Using a VoIP service, Customer A calls Customer B. The call is routed by the VoIP service provider to the PSTN operator in Country A. The PSTN operator transmits the call through an international gateway operator in Country B. The operator's NP DB is interrogated and the call is then sent to the correct terminating operator.
- ➔ **PSTN breakout at terminating side:** Using a VoIP service, Customer A calls Customer B. The call is routed by the VoIP service provider through the Internet backbone to the country where Customer B resides. The VoIP service provider interrogates the operator's NP DB and then sends the call to the correct terminating operator.

Figure 4: Local breakout at the terminating side for VoIP calls

3.2.5 Access by commercial entities for outbound calling

Some commercial entities with a high volume of calls establish agreements with several fixed and mobile operators so that calls can be terminated “on-net” in order to reduce call costs. This is illustrated in Figure 5 below. In markets where the penetration of NP is high, these organisations do not have the necessary information to efficiently route calls to the correct terminating operator. For these types of organisations, having access to NP Data would be useful to identify the correct terminating operator associated with a ported number in order to reduce costs.

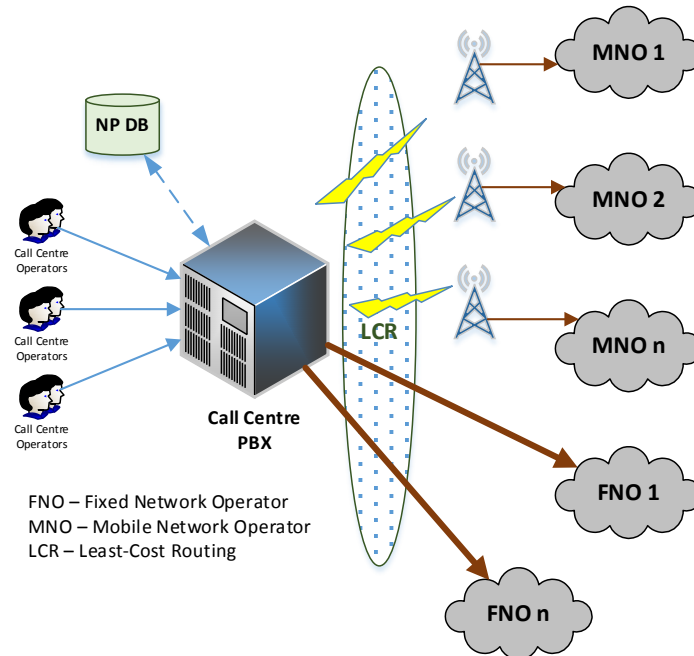

Figure 5: Outbound calling using LCR

4 CURRENT ACCESS POLICIES

ECC benchmarks and surveys demonstrate that NP implementations vary in Europe. The ECC Recommendation on NP Best Practices⁶ and other ECC deliverables aim to harmonise NP implementations. Even though most countries have implemented a NP CRDB model (some countries, e.g. Austria, Germany, Malta, Cyprus, Italy and the UK have not⁷) the governance arrangements may differ. The different implementations of NP are described in ANNEX 2. The NP CRDB can be managed by a commercial entity, by an operator consortium, by the NRA or by other governance arrangements. Such differences may affect the way 3rd party access to NP Data requests are handled.

3rd party access can be divided into access for individual queries for informational purposes as discussed in section **Error! Reference source not found.** below or access to a complete set of NP Data for routing purposes as discussed in section **Error! Reference source not found.**

4.1 ACCESS POLICIES FOR INFORMATIONAL PURPOSES

In terms of publically available websites, 13 countries that responded to an ECC questionnaire⁸ on 3rd party use have such websites. Four of the 13 countries indicated that information is only available for mobile numbers. These websites are available free of charge for the public based on individual queries and provide information on the service provider associated with a specific number.

Based on the inputs from countries that have such a solution, privacy issues are not that relevant due to the fact that no names or contact information are disclosed. The information is not deemed to be of a personal nature and cannot be used to identify individuals. Only information about the number and the associated service provider is given.

Several countries who have not implemented this service yet, are considering to do so. In other countries it is argued that this facility is not necessary due to having a mechanism (beep, announcement or other solution) to alert the user when the number is ported. However, even though such a mechanism may be sufficient to resolve the issue of tariff transparency, end-users may have use for information about a number's current service provider, e.g. in cases of misuse of premium rate numbers or other complaints, as mentioned under 3.1.

In a few countries the operators consider the contents of the NP CRDB as commercially confidential and are not in favour of making any of this information publically available to 3rd parties.

4.2 ACCESS POLICIES FOR ROUTING PURPOSES

3rd party access to NP Data is provided in seven European countries that responded to the ECC questionnaire. In some countries access is only given to operators who need access to fulfil NP obligations.

Some of the regulatory considerations that have been made when giving access to 3rd parties relate to justification of need, potential impact on NP processes (if any), cost of access, data protection and privacy concerns.

⁶ [ECC/REC/\(12\)02](#)

⁷ Mobile and fixed NP implementation can be different, even in the same country.

⁸ The ECC Questionnaire was circulated in 2014. 20 responses were received.

5 CONDITIONS AND TERMS OF USE OF 3RD PARTY DATA

As shown above NP Data is becoming increasingly important for many different stakeholders for the efficient routing of calls and messages and for informational purposes in order to promote tariff transparency. In order to define and allow for the use of NP Data for these specific purposes and to prevent misuse of the NP Data for other purposes this section identifies different conditions and terms of use for 3rd party access. The terms and conditions may vary depending if the purpose for access is commercial or informational.

5.1 OWNERSHIP OF THE DATA AND INTELLECTUAL PROPERTY RIGHTS

Access to NP Data may be determined by the governance arrangements that have been established around the development and maintenance of NP CRDB. In some countries the development and maintenance of the systems have been and are currently within the remit of the NRA. In other countries the systems were developed based on design principles approved by the NRA but the cost and day-to-day management and maintenance are the responsibility of a consortium of industry stakeholders with the NRA only typically becoming involved in policy issues and to assist new market entrants to establish services. Therefore, the challenges for NRAs associated with facilitating 3rd party access to NP Data may be different in different countries. The terms and conditions of access would need to be clear and any ownership or property right in the systems or data would need to be established before a harmonised European approach could be introduced.

5.1.1 Intellectual Property Rights (IPR) Related to the NP database

According to EU regulation⁹ a database is a collection of independent works, data or other materials arranged in a systematic or methodical way and individually accessible by electronic or other means. The core of the concept is that the user of a database has the opportunity to locate and retrieve the information needed from the database on the basis of individual criteria.

The database itself may be protected if the construction or structure of the database is original (copyright protection) or if the database represents qualitatively and/or quantitatively a substantial investment in either the obtaining, verification or presentation of the data in the database (sui generis protection). The functionality and structure of the database determines the information needed. The investment is measured on economy, creativity, resources used etc.

5.1.2 Ownership of NP Data

The NP Data needed to derive routing information consists of a service provider identification code or routing number associated with a number. This information would not constitute material that falls under IPR protection and therefore does not belong to anyone.

As a conclusion, and independent of who has the ownership of the database, access to NP Data shall be restricted to data relevant for routing purposes or for information to users in order to allow tariff transparency and to fulfil informational needs.

5.1.3 Nature of the Data

The NP database may contain information that is confidential or commercially sensitive and information that is not. The information could be used for different purposes. NP Data would in general not be confidential in nature, but because of commercial sensitivities access should be limited. For example, it is not acceptable to have access to the contents of the database for marketing purposes. Therefore it is logical that the NP Data is accessible to 3rd parties only with the acceptance of the entity responsible for the development and/or administration of the database in order to avoid misuse. All other information contained in the database may be considered confidential and commercially sensitive and should not be made available to 3rd party access seekers.

⁹ Directive 96/9/EC of 11 March 1996 on the legal protection of databases

5.2 COMMERCIAL ACCESS – CONDITIONS AND TERMS OF USE

5.2.1 Access on a cost recovery basis

In order to recover the costs of development, administration and maintenance of the NP CRDB, a fee for 3rd party access to NP Data could be imposed. Any such fee for access should be based on a cost recovery model. This means that the entity managing the NP CRDB should in general be entitled to charge a fee from 3rd parties seeking access to the data. For 3rd parties with a commercial incentive for gaining access in order to efficiently and correctly route calls and messages as part of their commercial business a fee seems appropriate. The fee could consist of an initial set up fee and an ongoing monthly or annual fee to cover the maintenance and ongoing development of the database to allow this 3rd party access.

5.2.2 Access based on contract

Today, in countries where a NP CRDB model is implemented to ensure the operation of a secure system to support the NP process, operators that have NP obligations would most likely have access to the NP CRDB based on a contract with the entity responsible for the NP CRDB. For the 3rd parties identified in this report that do not have NP obligations, but may have a justifiable need to gain access to NP Data, access could easily be based on a contract.

For reasons of information, awareness and transparency to the public such contracts should be publicly available.

5.2.3 The use of NP Data

Access to NP Data should only be granted for clear and defined purposes identified in this Report and should only be given when a justifiable need is present. The promotion of efficient routing and correct charging would in this Report be a justifiable need for gaining access. Any other use or the reselling of this data would on the other hand not be a justifiable need.

NP Data was and still is primarily used to route and charge calls or messages efficiently and correctly. The information can however be used for other purposes, e.g. reselling of information on an underlying network or service provider associated with a specific number. The efficient routing and correct charging of calls and messages (including video, RCS and any other form of communication that uses a telephone number to identify the destination) should be the only purpose for letting 3rd parties with a commercial incentive gain access to this data.

5.3 END-USER ACCESS – CONDITIONS AND TERMS OF USE

5.3.1 The use of NP Data

Access should only be granted for clear and defined purposes as identified in this report and should only be given when a justifiable need is present. End-users who may be price sensitive about the call they make could have an interest in getting information about whether a call is on-net or off-net or in case of misuse or a complaint. Preserving tariff transparency and identifying the underlying network and service provider of a ported number in case of misuse or a complaint and other cases as mentioned in section 3.1 constitutes a justifiable need.

This information should be made available only in an easily accessible format to allow end-users to search, on an on-demand basis, and determine the underlying network and service provider of a number that they wish to dial or retrieve information about.

In order to prevent the use of the facility by machines (e.g. web crawlers and robots), it should be considered some mechanisms in order to avoid abuses of this facility such as the recreation of the NP DB through the use of multiple queries.

Countries that have already implemented this functionality have used different protection mechanisms, like:

- Allowing only a limited number of queries (e.g. based on the IP address);
- Using characters in pictures to be inserted in a field;

Figure 6 shows two examples of this kind of mechanisms.



Figure 6: Examples of Web based access control mechanisms

5.3.2 Access free of charge

The reasoning for gaining access could have an impact on whether a fee is appropriate. The consumer interest indicates that end-user's access to information should be easy and free of charge.

5.4 OTHER ISSUES RELATED TO GETTING ACCESS

5.4.1 Privacy issues

Privacy issues seem not to be relevant in relation to giving access to NP Data. The information for which access should be provided should be held up against the purpose of getting the information. NP Data is not of a personal nature and cannot be used to identify individual subscribers. The data is used to identify the underlying network and service provider associated with a specific number. Some entities may however argue that the data contained in the NP CRDB is commercially sensitive and would therefore argue against making any of this data publicly available.

5.4.2 Jurisdiction

Jurisdiction is not problematic when it comes to national operators or other commercial entities in a country seeking access to NP Data for routing purposes in that same country. The legislation of the country concerned will apply. Problems could occur in relation to international operators or entities seeking access to NP Data of another country than where the operator or entity is located. Jurisdiction issues should be addressed in a contract between the entity administrating the NP CRDB and the entity seeking access. Disputes should be handled in accordance with the regulation in the country where the NP DB is located.

5.4.3 Monitoring compliance and enforcing regulations around the use of NP Data

The use of NP Data shall be monitored by the relevant entity or NRA depending on the arrangement for the provision of the data. In order to avoid the misuse, the 3rd party use of NP Data should be specified and the rules may preview penalties for misuse. Types of misuse (e.g. SPIT) of NP Data could also be defined in such mechanisms.

6 CONCLUSIONS

NP has promoted competition and consumer choice in electronic communications by enabling subscribers to seamlessly switch between operators while retaining the original number. NP has however introduced complexities in terms of call routing and the erosion of tariff transparency. As new service providers with alternative business models emerge on the market, the need for access to NP Data is increasing and these entities may have a justifiable need to have access to this data.

The access to NP Data by 3rd Parties discussed in this Report is limited to data used to derive the terminating operator associated with a ported number. It does not extend to confidential, personal or commercially sensitive information or information regarding the NP processes contained in the NP CRDB.

This report concludes that:

- Access to national NP Data should be provided to 3rd parties for the purposes of implementing more efficient routing and/or to increase tariff transparency.
- For commercial users who plan to use NP Data to implement more efficient routing, access to this data should be based on a contract with the entity, or one of the entities, responsible for the administration of the NP Data. If fees are imposed for 3rd party access they should be based on a cost recovery model.
- For end-users access should be offered in an easily accessible format and free of charge to promote tariff transparency and fulfil informational needs.
- NP Data should not be used by 3rd parties for sales, marketing, promotional or other commercial activities or resold to any other entity.

ANNEX 1: ROUTING OF TRAFFIC BEFORE AND AFTER NP IMPLEMENTATION

This annex describes how NP has impacted call routing and how technology and service innovation has led to the emergence of entities with new and alternative business models with a need to access NP Data.

A1.1 BEFORE NUMBER PORTABILITY

Traditionally, the relationship between numbers and service providers was static. When the NRA assigned a number range to an operator it was notified to all other operators and they updated the routing tables in their networks accordingly. They were then able to terminate calls efficiently. If there was no direct interconnection between networks, then transit arrangements via a third operator were put in place. This traditional model is illustrated in Figure A1.1 below:

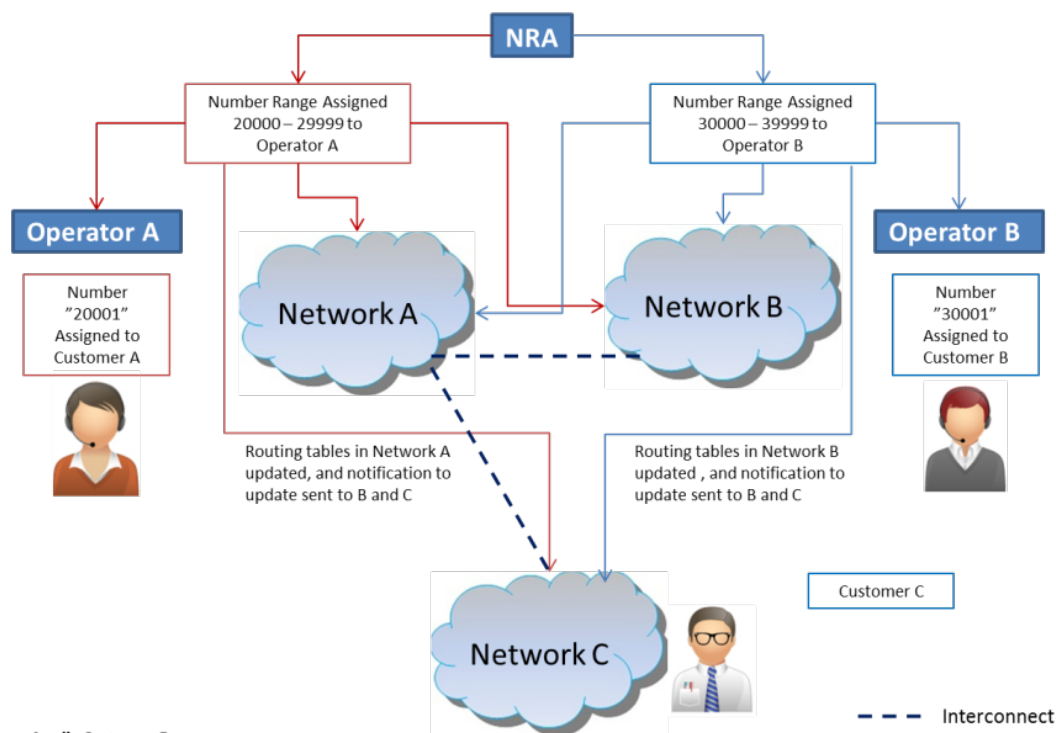

Customer A calls Customer B.

Customer A dials 30001. Operator A interrogates its own routing tables and determines the correct routing information to terminate the call at 30001. The call is sent over the interconnect between Operator A and Operator B and Operator B terminates the call at Customer B.

Customer C calls Customer B.

Customer C dials 30001. Operator C interrogates its own routing tables and determines the correct routing information to terminate the call. As Operators B and C have no direct interconnect between their networks, the call is "transited" via Operator A to Operator B. Operator B then terminates the call at Customer B.

Figure A1.1: Simple Call Routing before NP

It should be noted that in the example above, customers were usually aware of the terminating operator when they dialed a number. This awareness was based on recognition of the leading digits of the number which made it possible to determine an approximate call cost.

A1.2 AFTER THE INTRODUCTION OF NP

Following the introduction of NP, the routing process became more complex as end-users had the option of taking their number with them while moving to a new service provider. The example in Figure A1.2 below uses the ACQ and NP CRDB to illustrate the change.

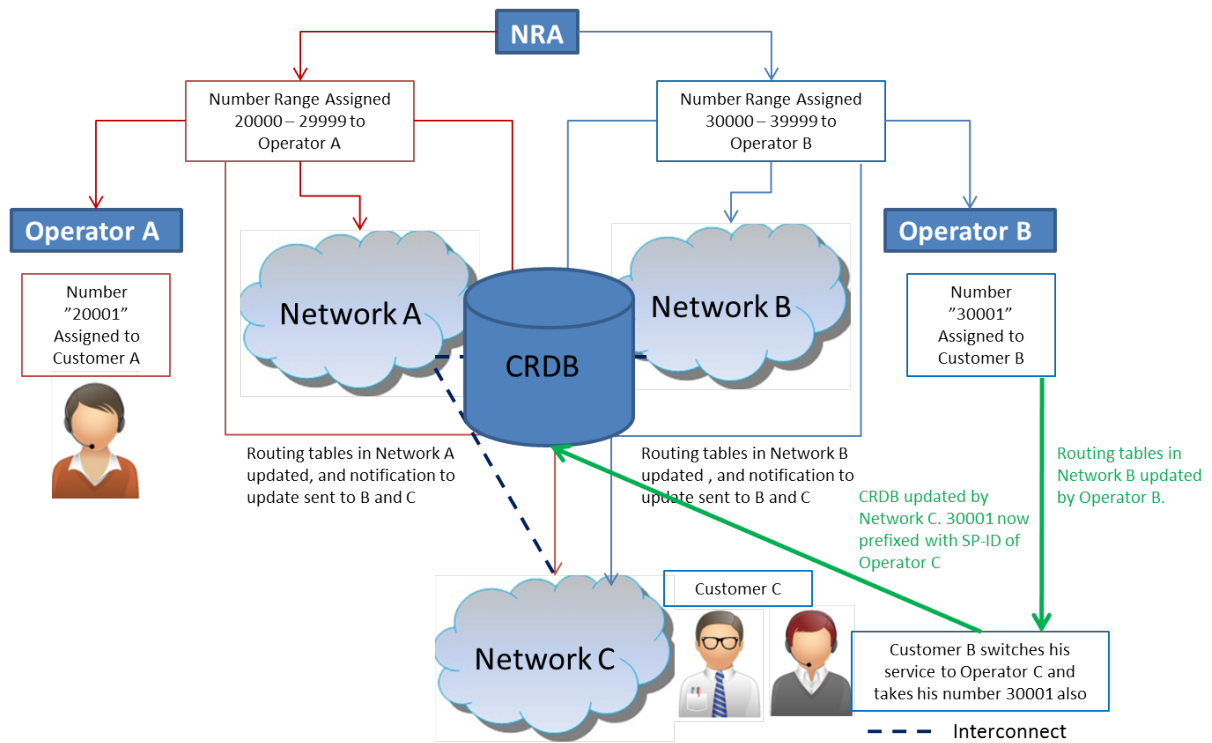

Introduction of NP

A number portability CRDB is installed and each authorised operator has access to it. As numbers are ported a unique Service Provider Identification Code (SP-ID) is assigned to each ported number so that the terminating operator can be identified. Every time a call is made (All Call Query - ACQ) the NPDB is interrogated to identify the correct terminating operator.

Customer A calls Customer B.

Customer A dials 30001. Operator A interrogates the NPDB and determines that the number belongs to a customer on Operator C's network. The call is sent over the interconnect between Operator A's network and Operator C's network and Operator C terminates the call at Customer B.

Figure A1.2: Call Routing after Introduction of NP

A1.3 IMPLICATIONS FOR THE ROUTING OF INTERNATIONAL TRAFFIC

The efficient routing of international calls and messages has also become more complex since the introduction of NP. As NP systems are not integrated between countries then it becomes difficult for long distance service providers to negotiate access to all NP systems in all countries. Therefore, long distance calls and messages are normally "onward routed" when they arrive at the international gateway switch of a destination country. The national operator receiving the call performs the NP look-up and onward routes the call or message to the correct terminating service provider. This routing scenario is illustrated in Figure A1.3 below:

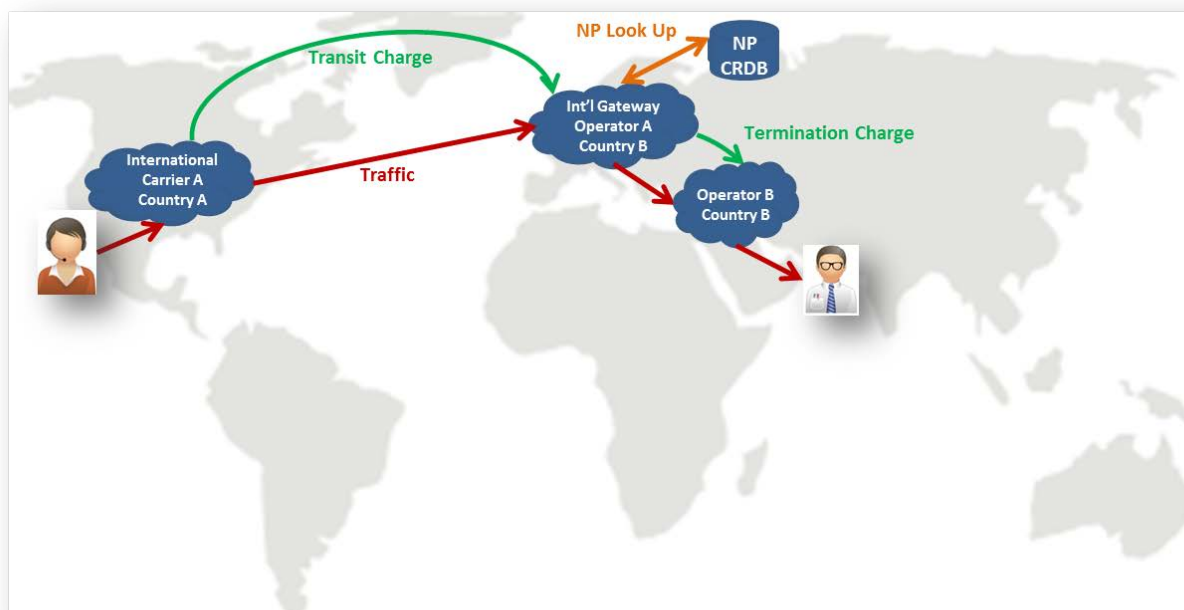

Figure A1.3: Diagram showing traffic originating in Country A destined for Country B showing associated transit and termination charges

There are a number of potential methods to address this challenge. These methods require operators to acquire NP Data from a variety of different sources which can be costly and difficult to manage. These include:

- Home Location Register (HLR) Lookup: This approach is commonly used by SMS Aggregators to determine the terminating operator (MCC+MNC) and these types of services specifically add high value in national markets where NP activity is high. A major advantage of this solution is that it offers information about which mobile operator a subscriber is served by and in which country the subscriber may be roaming. The performance of this solution is not always reliable and the agreement may be subject to commercial negotiations between SMS aggregators and MNOs. The agreement may also be subject to regulatory intervention at initial set-up.
- NP Data – This requires access to all national level NP CRDB in multiple countries where an international operator may need to terminate traffic. While this is a reliable method, it can be costly to implement and the conditions for access may vary between countries.
- Clearing House solutions – This type of solution is offered by a specialist provider to a complete global NP service. The operators of these types of services negotiate access to NP Data in multiple countries and provide the routing information as a commercial service. The functioning of the clearing house solution is illustrated in 3.2.2.

ANNEX 2: DIFFERENT IMPLEMENTATIONS OF NUMBER PORTABILITY

ECC/WG NaN has recently published the results of a comprehensive survey¹⁰ on NP implementations in CEPT countries. The way NP has been implemented varies throughout Europe but in most countries a NP Central Reference Database (NP CRDB) is used. This database contains *inter-alia* an entry for each ported number and the current responsible service provider for that number.

A2.1 NP ROUTING METHODS

A2.1.1 ACQ routing method

Also in most countries¹¹ the porting process is recipient-led and the traffic routing is based on All Call Query (ACQ). This method is based on the principle that the originating network has access to the NP DB and queries its operational database for all (independent the number is ported or not) calls in order to obtain the destination network (i.e. the recipient network in case of a ported number). Figure A2.1 shows the routing method for this scenario:

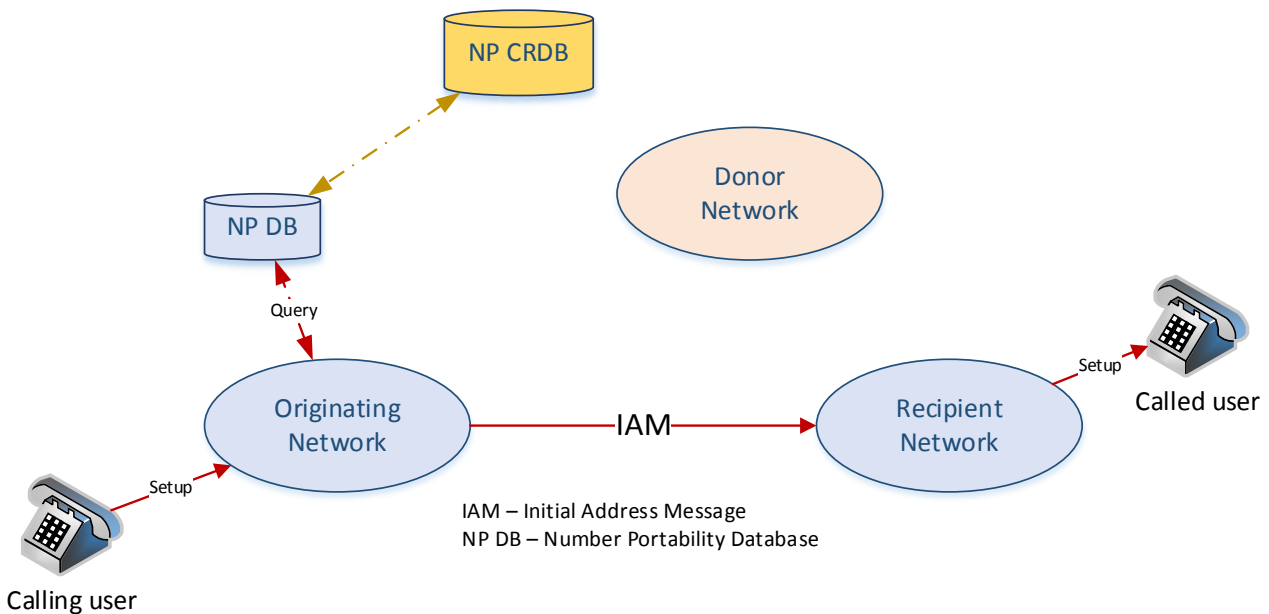

Figure A2.1: ACQ routing method

A2.1.2 Direct routing method

With regard to non-call related communication services (e.g. SMS), the scenarios used are different. There are two options available in the standards¹²: Direct and indirect routing methods. The first method is only possible in national environment or when access to NP Data is available to the SMS service provider. The originating network queries its own NP DB in order to obtain the destination network, routing directly to it. Figure A2.2 shows, in a simplified way, the routing method for this scenario:

¹⁰ [Number Portability Implementation in Europe – based on a survey of CEPT Member Countries](#)

¹¹ There are also implementation using Query on Release (QoS) and Onwards Routing methods.

¹² ETSI EN 301 716 - Support of Mobile Number Portability (MNP); Technical Realisation; Stage 2

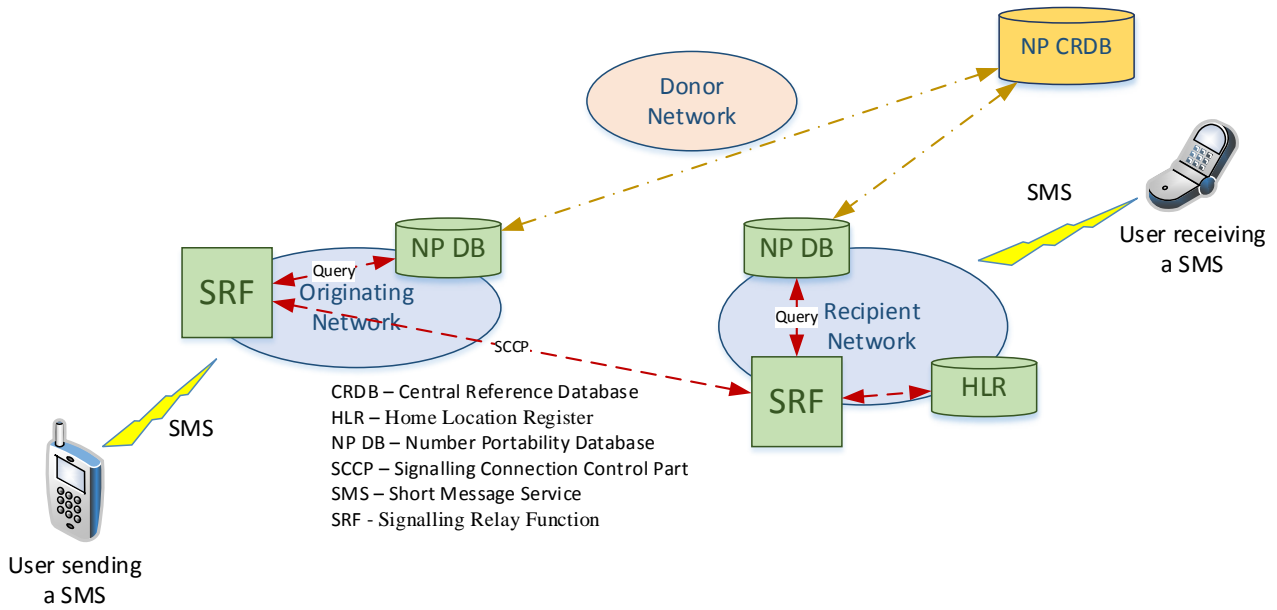

Figure A2.2: Direct routing method

A2.1.3 Indirect routing method

In international scenarios the most used case, since operators do not have access to NP CRDBs in all countries, is the indirect routing methodology where the donor network executes a signalling relay function to messages belonging to ported numbers (equivalent to a transit function). This methodology is shown in Figure A2.3 below:

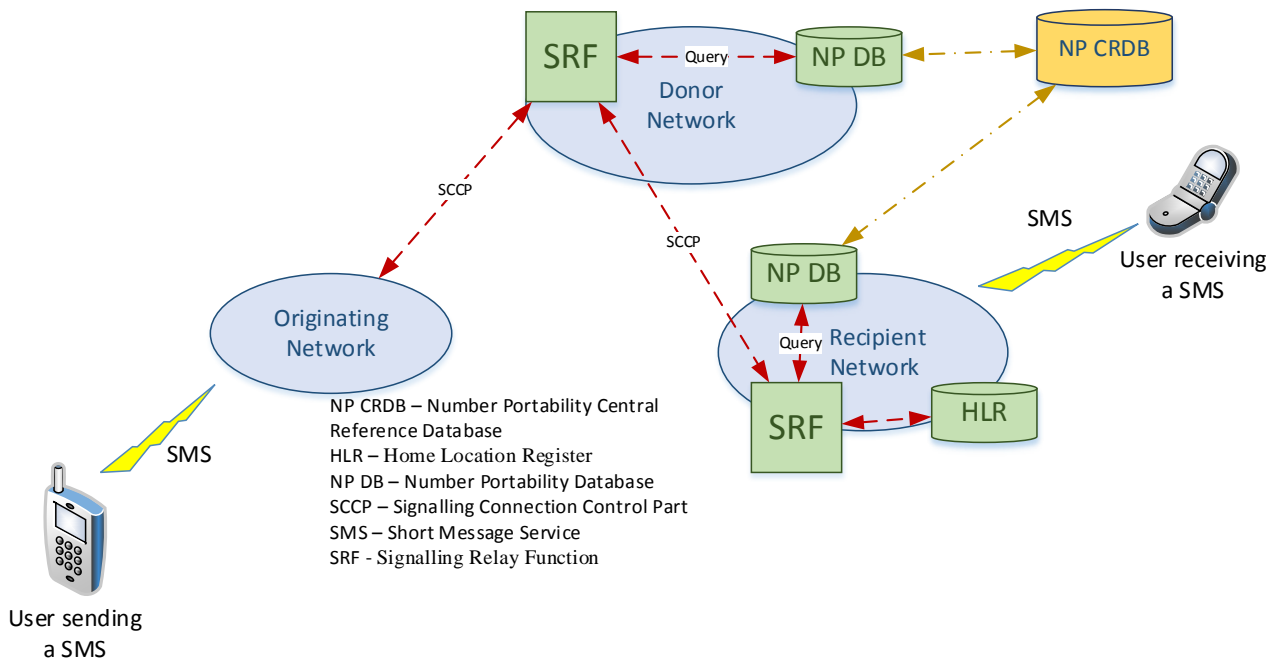

Figure A2.3: Indirect routing method

A2.1.4 Access and use of NP Data

Depending on the model adopted in each country, the access to NP Data can be done in different ways. Figure A2.4 describes generic configurations of databases where NP Data could be accessed.

On the right side of the picture is shown a possible future solution for NGN, where Infrastructure ENUM is one of the technical solutions for data retrieval. This method is out of the scope of the Report.

On the middle of the figure it is represented the CRDB that was mainly discussed in the Report. As shown, NP Data could be accessed by a 3rd party through the NP CRDB (National level).

The scenario described the left part of the picture illustrates a decentralised architecture, where NP Data could be accessed at the Operator level. Any Operator could be accessed by a 3rd party, since all the operators have a replica of NP Data.

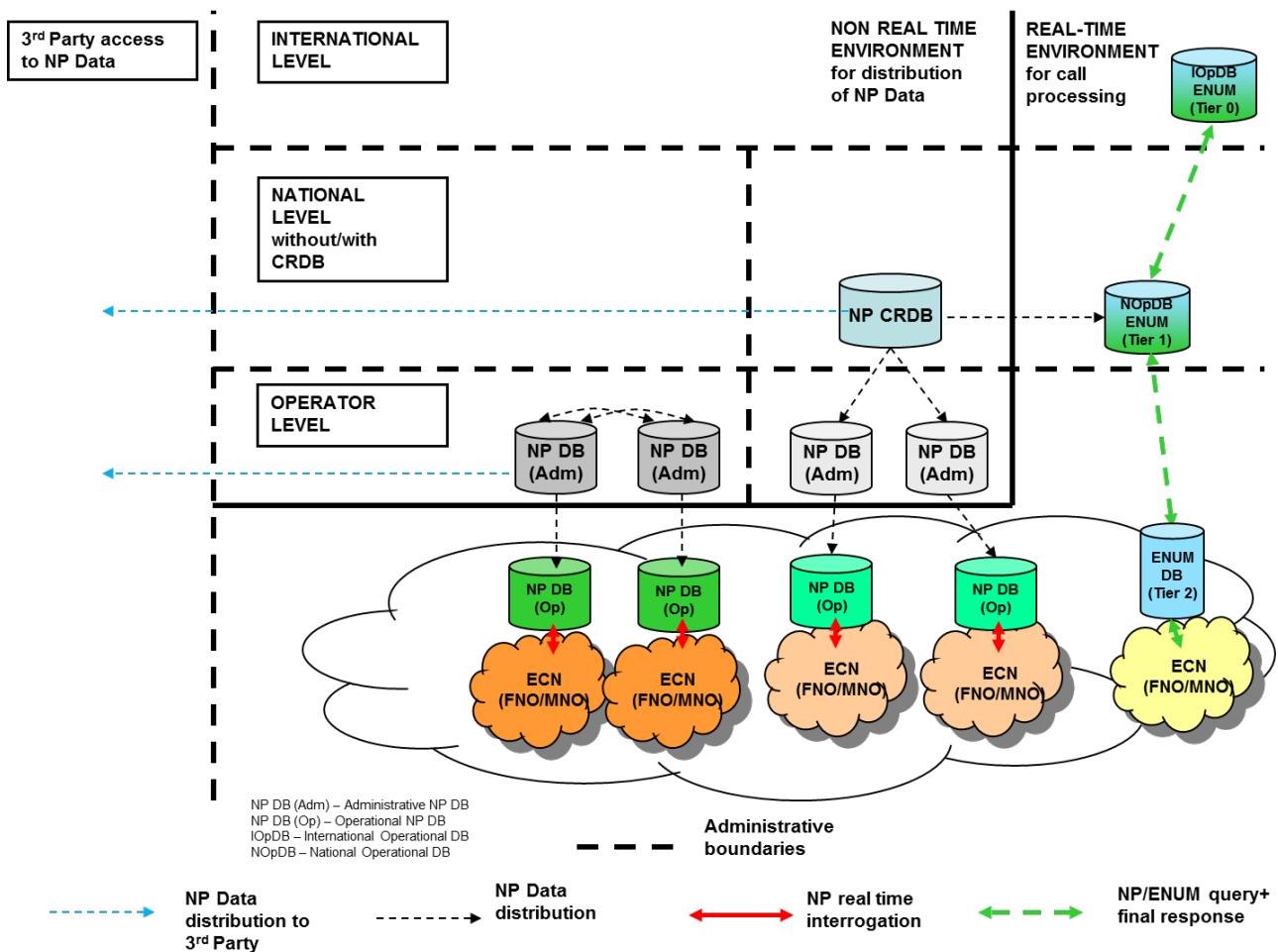

Figure A2.4: Access to NP Data solutions

A2.1.5 Access to and use of NP CRDB

Figure A2.5 below shows the architecture of the national CRDB in NP. It is possible that not all the architectural elements illustrated are included in national implementations. For example the middle layer (NP DB independent provider) is a theoretical possibility, but is not implemented in any European country.

The figure includes the following systems:

- NP CRDB – Central Reference Database - Centralised database where all information related to ported numbers is available (ported number with associated routing numbers and flows of the porting processes).
- Management System (NP DB (Adm)) – Network element that interacts with the NP CRDB and is involved in the NP processes and updates the real time NP DB (Op)
- Real time NP DB (Op) – Network element where all ported numbers associated with the routing numbers are available. It is this network element that is queried during call setup. Call Control – Network element that query, during call setup, the real time NP DB (Op). In most cases it is a switch.

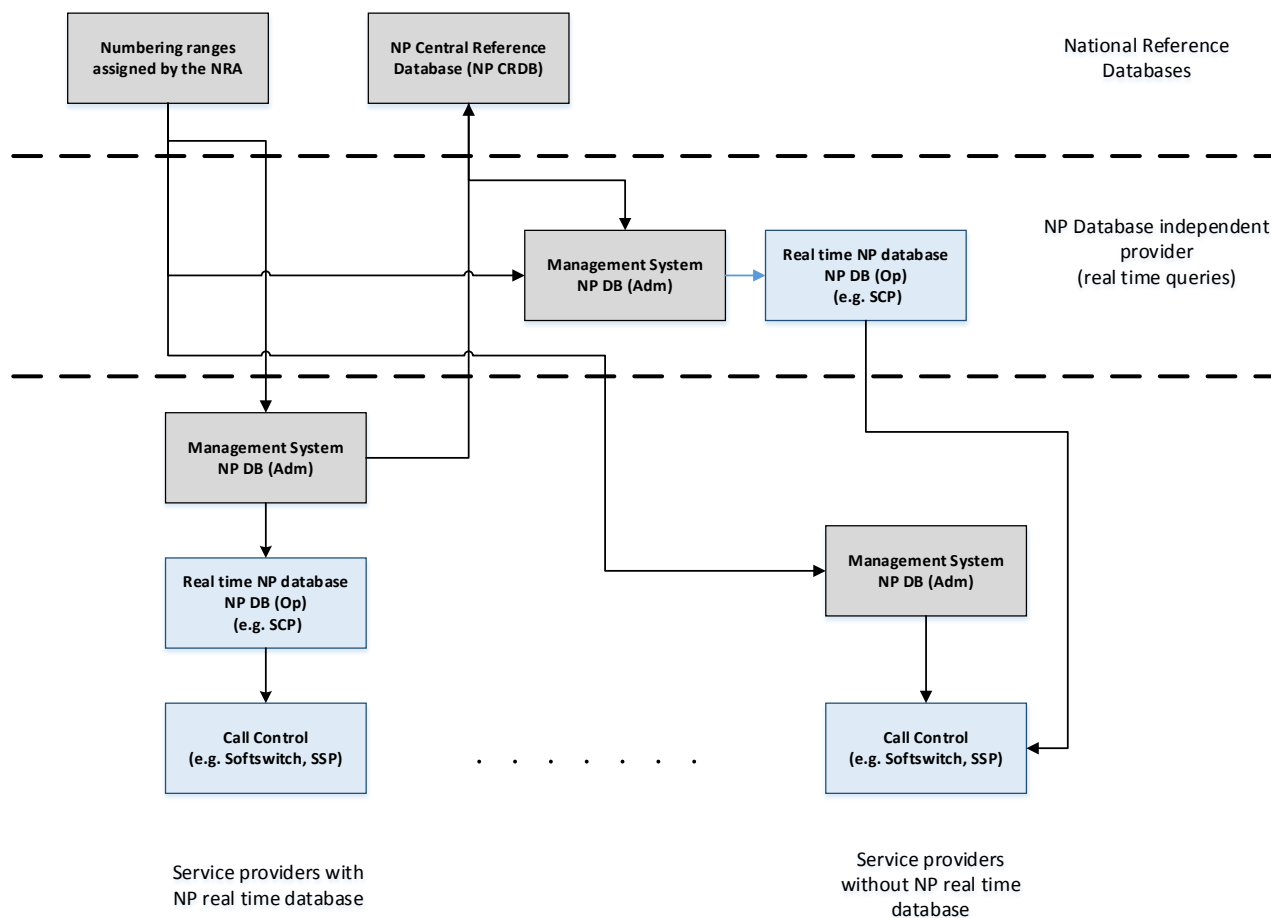

Figure A2.5: National NP CRDB architecture

The NP CRDB is the most interesting solution upon which to base an analysis of the issues associated with 3rd party access. Access to other solutions is more complex due to the fact that the DBs may be distributed or decentralised between several service providers.

A2.1.6 Decentralised DB in number portability

This solution is not so common in Europe, but there are a few implementations (e.g. fixed line solution in Germany or mobile solution in Italy). In this case all service providers have a complete picture of the NP Data¹³. For the description of the elements included in Figure A2.6 please refer to the subsection A.2.2.

¹³ In the case of Onwards routing methodology for NP, that not the case.

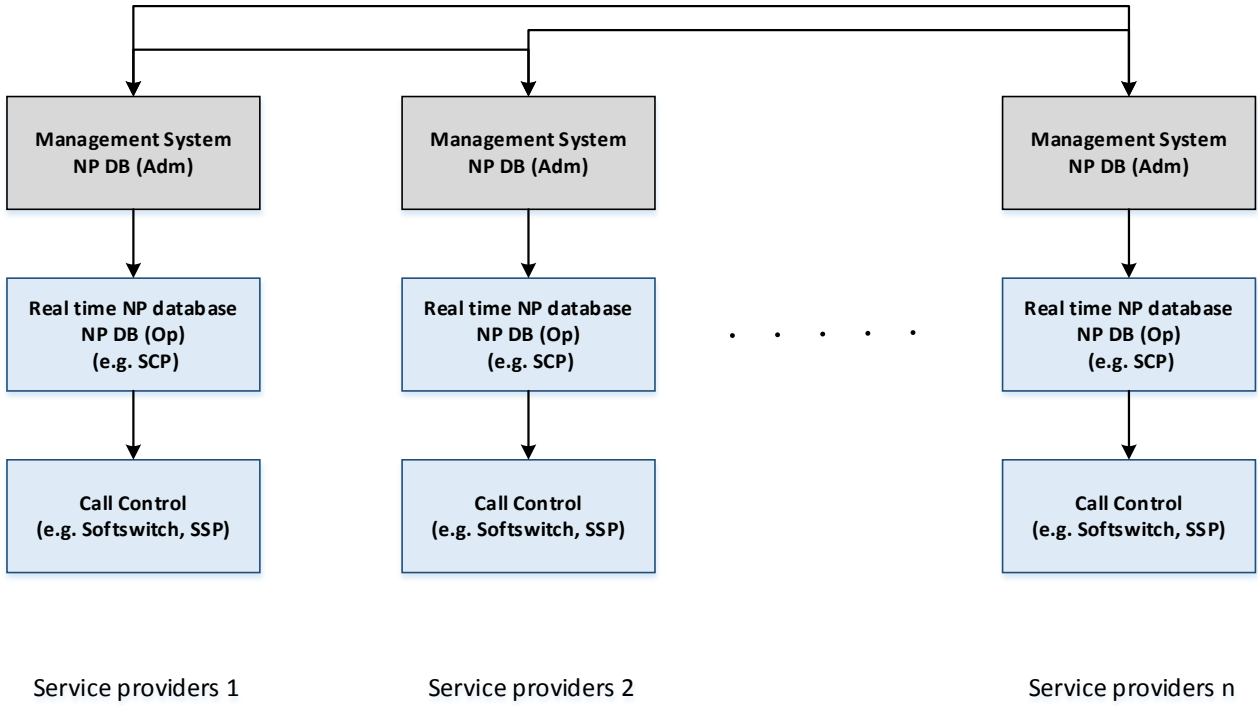

Figure A2.6: National Decentralised NP DB architecture

ANNEX 3: COUNTRY-SPECIFIC EXAMPLES OF DECENTRALISED NP DB IMPLEMENTATION

A3.1 MNP IN ITALY

For sake of an example, in Italy, the Ministry of Economic Development is the owner of the core system. This has the aim to constitute a MNP DB, which can be consulted by other administrations in particular for obligations related to the justice. Moreover, the Ministry provides the information related to the content of the database to the interested operator. This service is provided on the basis of an annual fee.

The mobile NP (MNP) DB architecture is distributed as it is shown in Figure A2.7. In this case, a core group of operators (MNO and MVNO that require to participate) exchange NP Data relative to the MNP for all ported numbers. All the other operators, fixed and MVNO that do not participate within the core group with its own Gateway (GW), receive, before porting take place, the NP Data relative to the mobile numbers that will be ported. With the distribution of the NP Data, all interested parties will know what to update in their NP DB in the future porting time frame. Consequently, it is possible to synchronize in specific time frame the updating of the NP DBs of all operators in Italy.

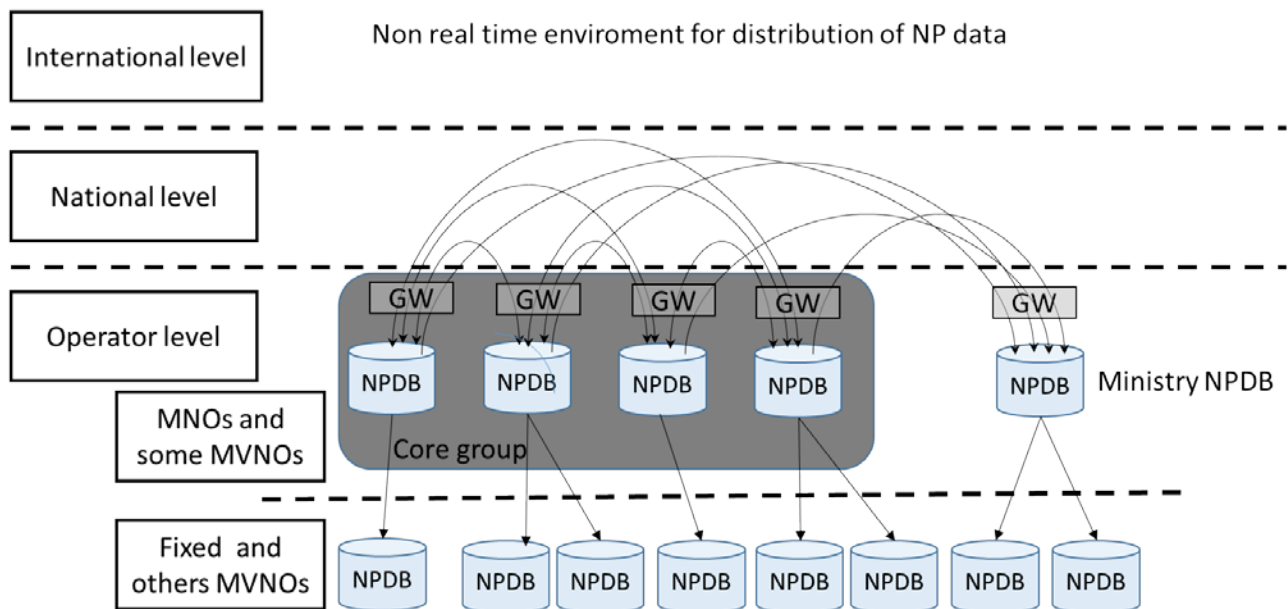

Figure A2.7: NP DB architecture (Source: Italy)

In Figure A2.8, the messaging flow is shown. The main concept is that, during the validation phase, only donor and recipient operators are involved. The information "porting indication" is distributed towards the other 3rd parties (mobile operators) belonging to the core group. All the operators belonging to the core group have the obligation to distribute free of charge the NP Data to other operators that need it before porting take place.

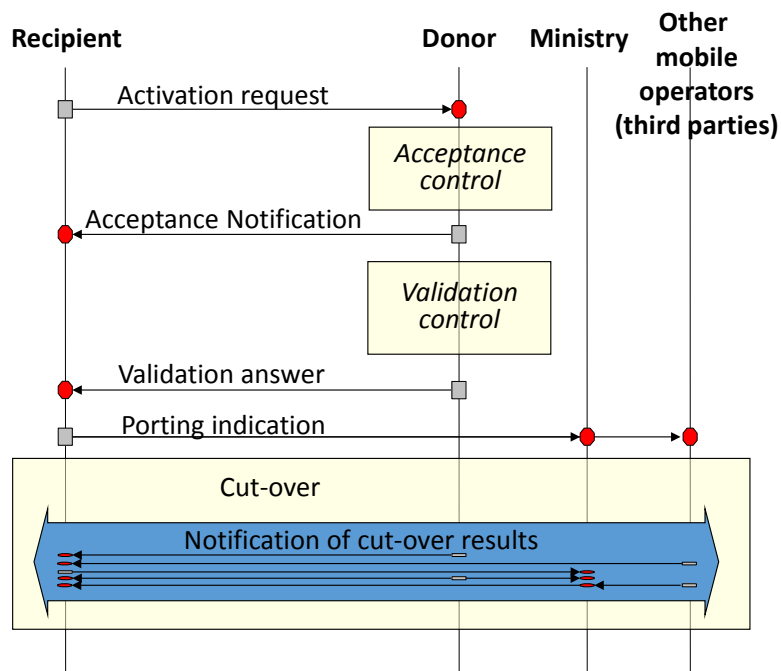

Figure A2.8: Porting Process in Decentralised Solution with notification of results (Source: Italy)

A3.2 FNP IN GERMANY

In Germany, for geographic numbers, a decentralised approach applies. Every network operator has to build and administer its own NP DB. The operator has to fill in NP Data on a day to day basis applying the specified data exchange vis-à-vis every single other operator. Every operator must provide each other with the necessary NP Data in a specified format. The NRA is generally not involved in this process except for declaring the binding specification for every operator dealing with geographic numbers.