



ECC Report 236

Guidance for national implementation of a regulatory framework for TV WSD using geo-location databases

Approved May 2015

0 EXECUTIVE SUMMARY

What are White Spaces?

DTT TV channels are broadcast using multiplexes. Each multiplex requires an 8 MHz channel and can carry several TV programmes. Multiplexes are transmitted at different frequency channels in the "TV broadcast band", currently frequency band 470-790 MHz (channel 21 to 60). The frequency band 694-790 MHz (channels 49 to 60) is planned to be released in the next years for MFCNs. In most geographical locations not all channels in the UHF band are used for the delivery of DTT services. Utilisation of the UHF band for DTT varies greatly dependent upon country, region, and geographical constraints.

The channels that are not used by DTT at any given location could be used under certain conditions by lower-power devices on an opportunistic basis. This opportunistic access to interleaved spectrum is not new. Programme making and special events (PMSE) equipment such as radio microphones and audio devices have been exploiting the interleaved spectrum for a number of years.

The spectrum that is left over by DTT, PMSE and other incumbent users is referred to as TV white spaces (TVWSs). This term is meant to indicate the combination of locations and frequencies in the "TV broadcast band" that can be used by new users without causing harmful interfering to DTT reception or any other incumbent.

What is geo-location database assisted operation?

White space devices (WSDs) operate in the TV band with the assistance of a database. A device will contact a white space database (WSDB) and provide to it its location and technical characteristics. The database holds information about the incumbents, and can calculate what channels and power levels are available at any location. The database will do this calculation for the specific location and technical characteristics provided by the device, and will communicate the available channels and powers to the device which can then start transmitting. Devices would normally connect to the WSDB over the internet.

Implementation by NRA and frequency band for WSD operation

One key feature of European regulatory developments on TVWS is that, consistently with conclusions in ECC Report 186 [1], a WSD may only transmit in the territory of a country if it has successfully discovered a geo-location database approved by the National Regulatory Authority (NRA). Rules defining WS availability and associated transmit powers are set by the NRA and are implemented in WSDB. This principle is well embedded in ETSI EN 301 598 V1.1.1 (2014-04) [2] on White Space Devices (WSD).

While this harmonised standard supports compliance assessment for Wireless Access Systems operating in the 470-790 MHz frequency band, it should be emphasised that administrations do keep control through database management on decision both 1) on effective implementation of a national regulatory framework allowing WSD in the TV broadcast band, subject to market demand and proper impact assessment on costs and benefits, and 2) on the effective frequency band where WSDs may operate.

Overall, this implies that practical implementation and authorisation can be responsive to the evolution of national policies in terms of primary users' spectrum allocation. For sake of consistency with the current spectrum allocation status in Europe within this frequency range and the existing harmonised standard on TV WSD, this report generally refers to the frequency band 470-790 MHz as the "TV broadcast band". This situation will of course be impacted by the decision at WRC-12 towards enabling the introduction of mobile services in the 700 MHz frequency band (i.e. 694-790 MHz) and subsequent European harmonisation process.

Costs and benefits analysis of allowing access to TV white spaces

The Report considers to what extent enabling TV White Spaces access could result in benefits to consumers, whether in terms of new services that may be provided or as existing services that could be delivered at lower prices and with higher quality. The 470-790 MHz spectrum is highly valued in terms of range, penetration and bandwidth.

Drawing on experience from the US and from the UK pilot, the Report proposes a more accurate representation of the types of applications that can be expected, while recognising that some use cases are still experimental and might never materialise as commercial propositions:

- Internet of things and machine-to-machine applications (Smart Cities, utility and farming monitoring...);
- Providing better Internet services to consumers (Increasing broadband speeds in hard-to-reach locations, adding additional capacity in wireless networks leading to faster internet speeds...);
- Providing backhaul;
- Pico broadcasting.

On the other hand, the costs incurred by the regulator could be higher than usual. This is because, in addition to the usual policy making work, WS operation requires a database. This means that the NRA has to engage in a number of tasks that would normally not be required. Depending on the framework that it decides to put in place with regards to the databases, the regulator may incur in the following:

- Collect and process incumbent data;
- Calculate TVWS availability;
- Select, approve and regulate databases – or alternatively run a database.

Risks, particularly for industry stakeholders, associated with uncertainties on the availability of white spaces, whether locally or as a consequence of change in primary users' spectrum allocation are also addressed.

Existing CEPT and standardisation work

The report recalls the scope of CEPT compatibility studies performed in relation with TVWS and provides an update on related published (in particular harmonised standard ETSI EN 301 598) [2] and ongoing standardisation work.

Device authorisation

An analysis is given on suitable regulatory regime for WSD. Overall, it suggests that a general authorisation model is adequate for TV WS, and likely to achieve efficient use of spectrum, noting that database assisted management of spectrum will technically achieve frequency coordination to ensure protection of incumbent which is, in practice, more close to a light licensed model than a pure licence exempt general authorisation.

There could however some new applications for which the delivery of an "individual right of use" could be justified in accordance with the authorisation directive, whether because a specific demand for devices which would cause interference if used under a general authorisation regime (e.g. manually configured devices, case of master device not having direct communication with approved WSDB or not having geo-location capabilities) or in view of introducing priority of access for certain WS devices.

White Space Database (WSDB) policy and provision

Main functions achieved by White Space Database (WSDB) would consist of the following:

- Collection of incumbent information;
- Provision of incumbent information;
- Calculation engine;
- Communications with the WS devices.

At the heart of the system, the calculation engine translates the information on incumbent services and the technical characteristics and location of the WS device into a list of allowed frequencies and associated transmit powers for devices. It should be noted that, depending on national frequency management organisation, the regulator itself may carry some of the translation processes by providing a dataset of

results to the databases – in the form of powers and channels available for WS usage at all points in grid covering the country. The DTT co-existence framework for calculating WSD powers, based on a pre-agreed interference limits can indeed require a significant number of complex calculations, often using data which is sensitive to the incumbent DTT broadcasters.

Options for provision of WSDB services

A NRA should consider, when addressing the question of who provides database services, the following options:

- The NRA itself performs the database tasks;
- The NRA subcontracts, and pays for, the services carried out by the database;
- The NRA allows for commercial databases, whose revenues come from charging the end users but not the NRA.

The report considers pros and cons of these alternatives as well as the question of how many databases should be authorised, i.e. one single database vs multiple databases. If multiple WSDBs are authorised, the NRA should not seek to decide which the right number is. The Report notes that multiple databases may carry high management costs to the NRA if the number of candidates is high. The NRA could recover the costs by charging for the authorisation process.

Charging cost and recovery considerations

Flowing from the various exchanges of information in relation with TVWS database management, the NRA and incumbents will face costs from collecting, aggregating and updating data on available spectrum for use by WSDs. The NRA will also incur costs in establishing and updating the algorithm and monitoring the accuracy of the third party database/s used by WSDs. Although making spectrum available to WSDs should not significantly increase the risk of interference to the licence holder if the coexistence framework is done right, there may nevertheless be an increase in the enforcement costs to the NRA of detecting and resolving interference. Finally, the database provider/s will also incur costs in setting up their systems and responding to WSDs' requests.

An NRA should consider who ultimately bears the costs of making spectrum available for WSD use, i.e. should incumbents, NRA or database providers be able to pass these costs on the end user.

WSDBs regulation and requirements

Database assisted operation is a new approach to managing spectrum and as a result there is no experience or a clearly defined framework for regulating databases. When considering how to put this in place, a NRA is likely to consider the following questions:

- How to ensure that only databases approved by the NRA provide service to devices;
- What is the legal instrument that enables WSDB operation;
- What are the obligations of a WSDB.

As a critical requirement, the NRA will want to be sure that a database performs the calculation process correctly as errors could lead to interference to incumbents.

How to prevent interference?

Section 7 on how to prevent interference distinguishes interference to incumbents from the issue of frequency congestion, i.e. coexistence between WSDs.

An overall methodology and possible common terminologies for defining technical rules to be implemented in WSDB in view of achieving protection incumbents is given in the Report.

This methodology, although based on the approach followed in the UK, is presented in a generic manner. It is likely that various enhancements could be envisaged. National administration wishing to implement geo-located TVWS regulations should take due consideration of national situation and identify necessary adjustments.

Concerning the issue of congestion, the report suggests that the NRA has in principle different alternatives. A first option could be to change the rules that WSDB follow when providing parameters to devices. A second option could be that WSDBs, or a separate entity, coordinate the access to spectrum - in a way similar to the Radio Resources Management function of a mobile network. The NRA could allow WSDBs, acting on a voluntary i.e. not regulated basis to coordinate device access to the spectrum. Alternatively, the NRA could consider mandating WSDBs to share the information about WS use and to coordinate access, noting that this can raise competition and data privacy issues to be properly investigated.

Decision and choices about mitigation of interference between WSDs would depend on the assessment of the risk made by the NRA. For instance when the density of use is very low, the best solution may be to do nothing as the likelihood of interference will be low. The choice of the most adequate solution is not straightforward and there is a risk of making the wrong regulatory choices in the absence of a clear understanding of what the interference scenario might look like. A key element for this is the knowledge of the types of applications and technologies that would be used in the band, and their characteristics in particular with regards to spectrum access profile (for instance short data bursts vs. continuous transmissions) and desired quality of service. With regards to applications, the evidence from the US and from the UK pilot show interest from a raster of applications that have very different spectrum access profiles. For instance, machine-to-machine communications have very low data rates and occasional transmissions, whereas pico-broadcast (operating as a WSD application) occupy a DTT channel continuously but are unidirectional. The ideal contention and interference management techniques would be very different for each. However, at this stage of development of WS use it is very difficult to determine what type of applications will take hold.

Other tasks of the NRA

Among other critical tasks for NRAs, the report underlines the need to provide some visibility on “WS availability” in a useful way. There is indeed a clear long-term risk to WSD services that access to spectrum will change dependent upon overall changes to the long term use of the UHF spectrum, changes to the DTT network, PMSE deployments, changes to the co-existence framework for interference mitigation and the potential for other WSD users.

The report also considers issues related to:

- gathering incumbent information;
- qualifying WSDBs and maintaining the list of qualified WSDBs;
- enforcement and interference management;
- staged introduction of TVWS spectrum regulations;
- review process implying ongoing NRA involvement in support of access to TVWS.

European perspective

This report aims to provide a comprehensive review of various issues to be considered by administrations wishing to implement TVWS regulations. Guidance is given in order to support proper assessment on costs and benefits, and practical feasibility of national implementation.

It may be worth to mention the fact that different circumstances indeed lead to different implementations and even different regulatory approaches.

Depending on national legislation, which could exclude for specific reasons the possibility of sharing with DTT in the UHF Band, TV White spaces may not be possible to be implemented at all in the UHF-Band.

Finally, from a European implementation perspective, it should be noted that ETSI EN 301 598 [2] contains the concept of the web-listing, which is the list of White Space Databases authorised by a NRA to operate in the geographical domain under the NRA’s jurisdiction, and that the EN includes requirements for White Space Master Devices to 1) obtain the web-listing and then 2) only contact a WSDB that appears in that web-listing.

In order to allow a timely update of regulatory information on national implementation status and provision of links to national web-listing when available, it is envisaged that ECC could manage through ECO a list of national web-listings within CEPT. The assumption is that each NRA which intends to implement TVWS regulations will create or make available a single web-listing which will contain web-links to the approved WSDBs for their territories. The national single web listing would be a device-readable list of WSDBs certified by the NRA whereas a general repository managed by the ECO would basically be a human readable web page.

TABLE OF CONTENTS

0	Executive summary	2
1	Introduction	12
1.1	What are White Spaces?	12
1.2	What is geo-location database assisted operation?	12
1.3	Implementation by NRA and frequency band of WSD operation	12
2	Definitions.....	13
3	Costs and benefits analysis of allowing access to TV white spaces	14
3.1	Introduction	14
3.2	Benefits for consumers	14
3.3	Potential applications and use cases	15
3.3.1	Internet of things and machine-to-machine applications	15
3.3.2	Providing Internet services to consumers.....	16
3.3.3	Providing backhaul.....	17
3.3.4	Pico broadcasting	17
3.4	Costs of allowing access to TV WS.....	18
3.5	Risks	18
3.5.1	Not enough TV white space is available in locations when/where it is needed.....	18
3.5.2	Availability of TV white space cannot be relied upon	19
3.5.3	TV white space spectrum may not be available indefinitely	19
3.5.4	TV white space spectrum may not be authorised throughout Europe.....	19
4	existing CEPT and standardisation work	20
4.1	CEPT studies on regulatory elements and operational requirements for TV White Space	20
4.2	ETSI Standardisation.....	20
4.2.1	ETSI EN 301 598	21
4.2.2	Coordinated and uncoordinated use in ETSI work	21
4.3	IEEE standardisation	21
4.4	IETF standardisation.....	22
4.5	Overview of TVWS developments outside Europe	22
4.6	Dynamic Spectrum Alliance.....	22
5	device authorisation	23
5.1	General principles.....	23
5.2	Authorisation regime for TV WSD	24
5.2.1	General authorisation.....	25
5.2.2	Individual authorisation	26
5.2.2.1	Devices which would cause interference if used under a general authorisation regime.....	26
5.2.2.2	Priority access	27
6	White Space Database policy and provision	28
6.1	WSDB functions.....	28
6.1.1	Collection of incumbent information.....	28
6.1.2	Provision of incumbent information.....	29
6.1.3	Calculation engine	29
6.1.4	Communications with the WS devices.....	30
6.2	Options for provision of WSDB services.....	30
6.2.1	Model 1 - the NRA manages the WSDB.....	30
6.2.2	Model 2 - the NRA outsources the WSDB function	31

6.2.3	Model 3 - commercial WSDB provider(s)	31
6.2.4	Conclusions	32
6.3	multiple WSDBs vs one wsdb	33
6.3.1	Single database provider	33
6.3.2	Multiple database providers	34
6.3.3	Limit on the number of WSDBs	35
6.3.4	Conclusions	36
6.4	Charging and cost recovery considerations	36
6.4.1	Introduction	36
6.4.2	Charging framework	37
6.4.3	Costs incurred by the incumbents	37
6.4.3.1	Cost recovery considerations	37
6.4.3.2	Conclusion	38
6.4.4	Costs incurred by the NRA	38
6.4.4.1	Cost recovery considerations	38
6.4.4.2	Additional considerations	39
6.4.4.3	Conclusion	39
6.4.5	Costs incurred by the WSDB provider	40
6.4.5.1	Cost recovery considerations	40
6.4.5.2	Conclusion	40
6.5	WSDBs regulation and requirements	40
6.5.1	Avoiding non authorised WSDBs	41
6.5.2	Legal framework for WSDBs	41
6.5.3	WSDB obligations	41
6.5.3.1	Compliance with the NRA requirements	41
6.5.3.2	Support to the NRA on interference management	42
6.5.3.3	Responsibilities in case of interference	42
6.5.3.4	Security	42
6.5.3.5	Data capture and reporting	42
7	How to prevent interference?	43
7.1	Interference to incumbents	43
7.1.1	Calculation of the WSD e.i.r.p. levels to ensure protection of incumbents	43
7.1.1.1	Protection of DTT	45
7.1.1.2	Emission limits for protection of cross border	46
7.1.1.3	Calculation of location agnostic limits	46
7.1.1.4	Combining of emission limits (P1)	46
7.1.1.5	Emission limits for protection of PMSE	46
7.1.2	Calculation of operational parameters	46
7.2	Interference from one WS device to another WS device and dealing with congestion	47
7.2.1	Options for dealing with interference and congestion	47
7.2.1.1	Device-based approach	47
7.2.1.2	WSDB coordination	48
7.2.2	Coordination technologies	48
8	other tasks of the NRA	51
8.1	Estimation of white space availability	51
8.1.1	General UHF spectrum availability for WSD	51
8.1.2	Longer Term WSD spectrum availability	51
8.1.3	PMSE Usage	51
8.1.4	Undertaking the Calculations and publishing the spectrum availability data	51
8.2	Gathering incumbent information	53
8.3	Qualifying WSDBs and maintaining the list of qualified WSDBs	53
8.4	Enforcement and interference management	54
8.5	Implementation considerations: staged introduction	54
8.6	Ongoing review	54
8.7	Cross border issues	54
9	Conclusions	55
	ANNEX 1: ETSI EN 301 598	56

ANNEX 2: High level description of the technical rules implemented for the UK pilot for calculation of operational parameters	60
ANNEX 3: Information on Dynamic Spectrum Alliance	72
ANNEX 4: List of Reference.....	73

LIST OF ABBREVIATIONS

Abbreviation	Explanation
CEPT	European Conference of Postal and Telecommunications Administrations
CDIS	Coexistence Discovery and Information Server
CM	Coexistence Manager
CRS	Cognitive Radio System
DSA	Dynamic Spectrum Alliance
DTT	Digital Terrestrial Television
ECC	Electronic Communications Committee
e.i.r.p.	equivalent isotropically radiated power
EN	European Standard, telecommunications series
ETSI	European Telecommunications Standardisation Institute
EU	European Union
FCC	Federal Communications Commission, USA
FWSD	Frequency of a White Space
GE06	International Telecommunication Union GE06 Agreement for Digital Broadcasting
GLDB	Geo-Location databases
HTTP	Hyper Text Transfer Protocol
IEEE	Institute for Electrical and Electronics Engineers
IETF	International Engineering Task Force
IoT	Internet of Things
ITU	International Telecom standardisation Union
NGR	National Grid Reference
NRA	National Regulatory Authority
PAWS	Protocol to Access White Space datababase
P_{DTT}	Maximum permitted in-block e.i.r.p. in a DTT channel
P_{IB}	In-block e.i.r.p. spectral density
PMSE	Programme Making and Special Events
P_{OOB}	Mean out of block e.i.r.p. spectral density
RF	Radio Frequency
RLANs	Radio Local Area Networks
RRS	Reconfigurable Radio Systems
R&TTE	Radio & Telecommunications Terminal Equipment
TVWS	TV White Space

Abbreviation	Explanation
UHF	Ultra High Frequencies
UK	The United Kingdom
WAS	Wireless Access Systems
WGS84	World Geodetic System, WGS 1984, EPSG:4326, established in 1984
Wi-Fi	Wireless Fidelity
WRC	ITU World Radio Conference
WSD	White Space Device
WSDB	White Space Database

1 INTRODUCTION

1.1 WHAT ARE WHITE SPACES?

DTT TV channels are broadcast using multiplexes. Each multiplex requires an 8 MHz channel and can carry several TV programmes. Multiplexes are transmitted at different frequency channels in the "TV broadcast band", currently frequency band 470-790 MHz (channel 21 to 60). The frequency band 694-790MHz (channels 49 to 60) is planned to be released in the next years for MFCNs. In most geographical locations not all channels in the UHF band are used for the delivery of DTT services. Utilisation of the UHF band for DTT varies greatly dependent upon country, region, and geographical constraints.

The channels that are not used by DTT at any given location could be used under certain conditions by lower-power devices on an opportunistic basis. This opportunistic access to interleaved spectrum is not new. Programme making and special events (PMSE) equipment such as radio microphones and audio devices have been exploiting the interleaved spectrum for a number of years¹.

The spectrum that is left over by DTT, PMSE and other incumbent users is referred to as TV white spaces (TVWSs). This term is meant to indicate the combination of locations and frequencies in the "TV broadcast band" that can be used by new users without causing harmful interfering to DTT reception or any other incumbent.

1.2 WHAT IS GEO-LOCATION DATABASE ASSISTED OPERATION?

White space devices (WSDs) operate in the TV band with the assistance of a database. A device will contact a white space database (WSDB) and provide to it its location and technical characteristics. The database holds information about the incumbents, and can calculate what channels and power levels are available at any location. The database will do this calculation for the specific location and technical characteristics provided by the device, and will communicate the available channels and powers to the device which can then start transmitting. Devices would normally connect to the WSDB over the internet.

1.3 IMPLEMENTATION BY NRA AND FREQUENCY BAND OF WSD OPERATION

One key feature of European regulatory developments on TVWS is that, consistently with conclusions in ECC Report 186 [1], a WSD may only transmit in the territory of a country if it has successfully discovered a geo-location database approved by the National Regulatory Authority (NRA). Rules defining WS availability and associated transmit powers are set by the NRA and are implemented in WSDB. This principle is well embedded in ETSI EN 301 598 V1.1.1 (2014-04) on White Space Devices (WSD) [2].

While this harmonised standard supports compliance assessment for Wireless Access Systems operating in the 470-790 MHz frequency band, it should be emphasised that administrations do keep control through database management on decision both 1) on effective implementation of a national regulatory framework allowing WSD in the TV broadcast band, subject to market demand and proper impact assessment on costs and benefits, and 2) on the effective frequency band where WSDs may operate.

Overall, this implies that practical implementation and authorisation can be responsive to the evolution of national policies in terms of primary users' spectrum allocation. For sake of consistency with the current spectrum allocation status in Europe within this frequency range and the existing harmonised standard on TV WSD, this report generally refers to the frequency band 470-790 MHz as the "TV broadcast band". This situation will of course be impacted by the decision at WRC-15 towards enabling the introduction of mobile services in the 700 MHz frequency band (i.e. 694-790 MHz) and subsequent European harmonisation process.

¹ In the UK, more than 50,000 licences are issued annually for this type of use

2 DEFINITIONS

Term	Definition
White Space	A part of the spectrum, which is available for a radiocommunication application (service, system) at a given time in a given geographical area on a non-interfering / non-protected basis with regard to other services with a higher priority on a national basis (From CEPT Report 24 [14])
TV White Space (TVWS)	White Space in the UHF TV broadcast band. The UHF TV broadcast band corresponds to frequency band 470-790 MHz at the time of publication of this Report.
White Space Device (WSD)	<p>White space devices are devices that can use White Space spectrum without causing harmful interference to protected services.</p> <p>For the purposes of this report, a white space device is a device which obtains operational parameters from a geo-location White Space Database (WSDB) approved by the NRA.</p> <p>For the purpose of this report, a White Space Device (WSD) relates strictly to the use of TV white space.</p>
Incumbent service	For the purpose of this report, an incumbent service is a service recognised on a national basis with a higher priority than the White Space Devices.
Coordinated use of white spaces /	Coordinated use of White Space implies that a WSD or a group of WSDs use available white space resources obtained with the help of the geo-location database and with additional knowledge of the current spectrum usage by other WSDs.
Uncoordinated use of white spaces	Uncoordinated use of White Space implies that each WSD independently uses available white space resources obtained with the help of the geo-location database without any additional information about the spectrum usage of other WSDs
White Space Database (WSDB)	<p>A geo-location database system approved by the relevant national regulatory authority which can communicate with WSDs and provide information on white space availability taking into account any operational changes from the protected incumbents.</p> <p>For the purpose of this report, a White Space Database (WSDB) relates strictly to the use of TV white space.</p>
Master WSD	A WSD that is able to communicate directly with a WSDB and with WSDs.
Slave WSD	A WSD that is only able to communicate with other WSDs, when under the control of a master WSD.
WSDB national web-listing	The list of White Space Databases authorised by an NRA to operate in the geographical domain under the NRA's jurisdiction.

3 COSTS AND BENEFITS ANALYSIS OF ALLOWING ACCESS TO TV WHITE SPACES

3.1 INTRODUCTION

This section considers to what extent enabling TV White Spaces access will result in benefits to consumers, and what form might those benefits take. TV White Spaces use is still nascent and new applications are being developed and tested. However, there are a few of these that can already be identified as being well suited to exploiting the characteristics of the TV White Spaces spectrum.

This section first studies how TV White Spaces can benefit consumers and what are the key characteristics that set this spectrum apart. Second, it draws on evidence from existing deployments and trials to identify the types of applications likely to make use of the spectrum. Finally, it considers briefly the costs involved in allowing access to white spaces and the risks associated with relying in TV white spaces to support services.

3.2 BENEFITS FOR CONSUMERS

Allowing access to White Spaces means spectrum can be used when it would otherwise remain unused. This could improve spectrum efficiency and benefit consumers because spectrum is a scarce resource for which there is strong demand. This is particularly the case for the spectrum in the UHF band. Consumers will benefit from making TVWS available in two broad ways:

- a) **New services may be provided.** The NRAs would normally not put any restrictions on the type of application that can use TV white spaces, or the number of users, provided the coexistence criteria are met. This may lower barriers to spectrum access. Making more low frequency spectrum available and lowering barriers to spectrum access may encourage uses of the spectrum to deliver services that do not currently exist. The scope for innovations in new services using TV white spaces could be important.
- b) **Existing services could be delivered at lower prices and with higher quality.** Prices may fall because lower barriers to spectrum access may promote entry resulting in stronger competition in some markets. Prices may also fall because the additional low frequency spectrum may save resource costs by allowing the same services to be provided more efficiently, with these lower costs feeding through to lower prices. Secondly, the increase in availability of spectrum may improve the quality of existing services. For example, communications providers may seek to deliver greater internet speeds or increase their network coverage using the TV white spaces spectrum. Citizens and consumers may also benefit from a reduction in congestion in other spectrum bands.

Although these benefits are to some extent relevant to making available any new spectrum band, the 470 to 790 MHz spectrum is highly valued because of the following:

- **Range** – it has much better propagation characteristics than spectrum found in bands higher up in frequency, such as the 2.4 GHz and 5 GHz bands used by RLANs;
- **Penetration** – it can penetrate through walls, trees and foliage more easily than spectrum found in bands higher up in the frequency; and
- **Bandwidth** – the UHF band potentially offers large bandwidths enabling greater data throughput, at least for some locations, depending on DTT and PMSE requirements (assessment of effective availability in the TV band of large bandwidths for alternative usage and of their adequacy for high data rate applications is a critical issue for stakeholders).

3.3 POTENTIAL APPLICATIONS AND USE CASES

The potential benefits above will only arise if there are applications that actually use TV white spaces once they are available. ECC Report 185 [4] introduces three broadly defined, potential use cases: machine-to-machine communications, indoor internet access and outdoor internet access. Since that Report was completed, there have been developments that allow us to build a more informed view of potential uses of the spectrum. Notably:

- In the US, the Federal Communications Commission (FCC) has allowed access to TV white space since 2012. Several commercial installations are operating, although the number of TV white space devices deployed as of mid' 2014 is limited.
- In the UK, Ofcom is conducting a pilot with around 20 public and private organisations where various applications will be tested. The trials have taken place in 2014/2015 and have served as a basis for finalising Ofcom technical rules.

Drawing on the experience from the US and from the UK pilot, it is possible to get a picture of the various types of applications that could appear in the near term. However a note of caution is necessary: although these applications might be better defined now than the broad use cases described in ECC Report 185, it must be recognised that in some use cases they are still experimental and might never materialise as commercial propositions. Key use cases that have emerged are briefly reviewed next.

3.3.1 Internet of things and machine-to-machine applications

The number of wireless machine-to-machine (M2M) connections has been forecast to multiply 10 fold from today to 2022.² These connections are expected to span a wide range of sectors. This will form the "Internet of things" (IoT) where communications will occur between machines. The range of possible applications of the IoT is large and growing, and their benefits are potentially significant.

Different IoT applications have different spectrum requirements and using TV white spaces may in some cases be particularly valuable. IoT applications often require transmission of a very small amount of data on an infrequent basis,³ devices that have long battery lives and low cost, and spectrum with good propagation characteristics.

Existing alternatives do not always meet these requirements. For instance, mobile networks may not be cost effective for the carriage of small packets of information and long life operation on batteries is not possible. Wi-Fi might be cost effective, but it may not meet the coverage requirements because it operates on frequencies that have poor propagation characteristics.

Industry has argued that sub 1 GHz would be ideally suited for IoT applications, as this spectrum can cover large geographic areas and has good in-building penetration⁴. Below are described a few of the IoT applications that may be particularly well suited to using TV white space spectrum.

Smart Cities

The IoT may help in creating 'smart cities' where for instance pollution, traffic flow, parking capacity and river levels will be monitored automatically. One example of such applications has been trialled in Oxford in the UK, where a citizen-led network of sensors to detect floods was set up, using white space spectrum to link to the sensors. Another example is a trial in Glasgow where TVWS has been used as the backhaul for outdoor video cameras and open-air Wi-Fi access points.

² In the UK, Ofcom expects this to rise from 30m to more than 360m by 2022. See Ofcom, *Spectrum Management Strategy*, 30 April 2014, Figure 3.

³ See Aegis and Machina research, *M2M application characteristics and their implication for spectrum*, report commissioned by Ofcom, April 2014. http://stakeholders.ofcom.org.uk/binaries/research/technology-research/2014/M2M_FinalReportApril2014.pdf

⁴ See Ofcom, *the future role of spectrum sharing for mobile and wireless data services*, April 2014, p.37, paragraph 6.7. http://stakeholders.ofcom.org.uk/binaries/consultations/spectrum-sharing/summary/Spectrum_Sharing.pdf

Utility and farming monitoring

Access to TV white spaces may help utility companies to match supply with consumer demand more efficiently. The use of resources may be automatically monitored and reported by white space devices, enabling providers to plan for and avoid peaks in demand they would not be in a position to meet.

Farmers may use the IoT to improve their yield and the quality of agricultural and livestock products. White space devices could be used to manage automatically the irrigation level, or the fertilisation of crops based on moisture levels or current and future weather. There have been trials in the US to use TV white space data links to control automated farming equipment such as tractors.

3.3.2 Providing Internet services to consumers

Access to TV white spaces may be used as a way to provide better Internet services to consumers, especially in hard-to-reach locations where superfast broadband is not available or in locations where wireless network connection is weak.

Increasing broadband speeds in hard-to-reach locations

There have been a number of trials using TV white spaces to provide broadband access in hard-to-reach locations including in Africa where fixed infrastructure may be scarce and in the US in rural locations.⁵ Although broadband coverage in Europe is normally high, there may be some scenarios where provision via TV white spaces makes commercial sense. For instance, one of the trial-lists in the UK will use TV White Spaces to deliver wireless Internet access to ferries operating between islands in the north of Scotland.

Second, access to TV white spaces may also increase Internet speeds in locations where superfast broadband is not available or where broadband speeds are limited. There are two possible scenarios for this:

- At locations with low population density deploying fibre may not be profitable. Using TV white spaces to deliver Internet at greater speeds may provide a cheaper alternative as it requires little initial investment in comparison to building or extending a fixed network;
- Allowing access to TV white spaces may reduce barriers to entry and allow potential wireless competitors to compete with fixed incumbents. Thus, even if there is already a fixed network, competition from wireless may result in lower prices and/or higher speeds.

These benefits depend on the availability of white spaces. TV white spaces are constrained by the need to protect DTT and PMSE use, but PMSE is likely to be rare in hard-to-reach locations. This means that the availability of TV white spaces in these areas is likely to be significantly greater, although some special events can occasionally require extensive spectrum resource assignment on a protected basis that would conflict with possible newly established WSD usage on non-protected basis.

An example of this type of application is one of the trials in the UK that will test the provision of broadband services in the South of England although solutions to provide Internet access may already exist in these locations.

However, as noted above these benefits are likely to be delivered to a small number of consumers in Europe because the number of homes with no access to high speed broadband is small and decreasing.

⁵ For instance, Google supported a trial in South Africa in 2013, to provide broadband access to 10 schools from Stellenbosch University in a 10-kilometer radius. Each school received a dedicated 2.5 Mbit/s connection. Similarly, both Google and Microsoft as member of the Air.U consortium have been involved in a project providing public Wi-Fi service on the campus of West Virginia since 2013. Finally, Microsoft has run trials in Africa. They range from enabling rural broadband access in Kenya and South Africa to building networks on university campuses in Tanzania. See Dougie Standford, *New FCC chair stresses importance of unlicensed spectrum*, Policy Tracker, December 2013

Adding additional capacity in wireless networks leading to faster internet speeds

In February 2014, the IEEE approved the 802.11af standard, which supports Wi-Fi over TV white spaces.⁶ This standard re-uses much of the traditional Wi-Fi technology, and could in theory achieve speeds up to 568 Mbps⁷. If manufacturers produce end-user devices that meet this standard, this may benefit consumers in two ways:

- By making additional spectrum available for Wi-Fi services, supplementing the existing Wi-Fi bands at 2.4 GHz and 5 GHz. As the existing bands become more congested (particularly the 2.4 GHz band), this may allow faster speeds than would otherwise be the case;
- As explained earlier, TV white space spectrum has favourable propagation characteristics compared to the existing Wi-Fi bands at 2.4 GHz and 5 GHz. This means using TV white spaces can provide access at a greater range, both indoors and outdoors, reaching locations that could not be reached with the existing Wi-Fi bands.

For example, within an in-home communication network, parts of the home can be difficult to reach with a Wi-Fi router operating on 2.4 GHz and/or 5 GHz spectrum. Using TV white spaces spectrum, it is much easier to achieve wireless connection in the entire household with transmitted power levels similar to what Wi-Fi uses today.

It is also possible that TV white space could be used by mobile operators as one way of adding capacity to their networks. If it were cost effective to do this, it could help to ease pressure on mobile networks' capacity resulting from steadily increasing demand for mobile data and coverage. However for this to be an option for mobile operators, there would need to be end user devices that supported the use of TV white spaces.

3.3.3 Providing backhaul

White space spectrum can also be used to provide backhaul links to access systems such as Wi-Fi hot spots. The 2.4 GHz and 5 GHz bands are not as well suited for backhaul due to the short range that can be achieved. In contrast, TVWS equipment can sustain links in more challenging environments without requiring a dense network of relays. Several of the trials in the UK have tested the viability of TVWS as a backhaul mechanism for Wi-Fi hotspots. In the US, TV White Spaces links are being used as a replacement for microwave fixed links in scenarios where non-line-of-sight conditions cannot be avoided.

3.3.4 Pico broadcasting

TV white spaces offer the possibility to deliver advertising content without Wi-Fi or cables/wires. In September 2012, a furniture store in Michigan started to use TV white spaces to beam content to 30 screens. More generally, TV white spaces may be used to deliver informational or advertising content in public places and offer the possibility to update in real time digital signs.⁸ A key advantage of TVWS for this type of application is that off-the-shelf TV receivers can be used – provided that the pico broadcast station transmits using standard DTV encoding. This application has also been successfully trialled in the UK.

⁶ The Institute of Electrical and Electronics Engineers (IEEE) is a worldwide corporate association that agrees on the standards to be used in wireless communications. The 802.11af standard is described here:

http://standards.ieee.org/news/2014/ieee802.11af_amendment.html

⁷ 35.6 Mbps per 8 MHz channels, 4 bonded channels, 4 MIMO streams per channel

⁸ For instance, see <http://www.meldtech.com/staging2/Online%20Pubs/The%20Space%20Between.pdf>

3.4 COSTS OF ALLOWING ACCESS TO TV WS

There are normally three costs drivers associated to opening access to a new spectrum band:

- Costs related to clearing the band from its existing users. Spectrum is now heavily used in most bands, so a NRA may have to clear the current use when it determines that a new use shall be allowed in a band. Current users are likely to incur in costs to reallocate to another band or to find a replacement for the service that had been provided in the cleared band. These costs can be substantial, for instance clearing the 800 MHz band to enable mobile use in the UK meant that DTT transmitters had to be retuned, and that TV receiver antennas had to be changed or upgraded at many locations across the country;
- Coexistence costs. When introducing a new spectrum use, there may be an increase in interference to existing users in adjacent bands – or existing users that share the band with the newcomer. As a result existing users may need to change or upgrade their equipment, or accept the degraded performance caused by the interference;
- Costs related to putting in place the new regulatory regime. The policy making process to enable a new use may require significant resources at the regulator. These are dedicated to the consultation process and to making regulations, to run a competitive award in some cases, and to support the new regulatory regime in an ongoing basis – for instance to police interference.

The first cost driver is not present in the case of enabling access to TVWS. This is because for its very nature, TVWS are spectrum resources that are unused, and hence incumbents in the TV band are not required to clear the spectrum or to move to another band. If access to TVWS is enabled on a non-interference basis, then the second cost element should not be present either. In any event, the level of interference that other users could suffer is driven by the power levels and channels that the geo-location database allocates to WS devices. The rules for the calculation of these are set by the regulator and can be very tight if tolerance to interference is low.

On the other hand, the costs incurred by the regulator could be higher than usual. This is because, in addition to the usual policy making work, WS operation requires a database. This means that the NRA has to engage in a number of tasks that would normally not be required... Depending on the framework that it decides to put in place with regards to the databases, the regulator may incur in the following:

- Collect and process incumbent data;
- Calculate TVWS availability;
- Select, approve and regulate databases – or alternatively run a database.

3.5 RISKS

This section considers some of the risks to the successful deployment of applications that use white spaces.

3.5.1 Not enough TV white space is available in locations when/where it is needed

The use of TV white spaces will be restricted as necessary to ensure a low probability of harmful interference. In particular, TV white spaces will need to be restricted to accommodate PMSE use. PMSE use will vary greatly from one location to another. For instance, PMSE use at a rural location is rare and therefore there will normally be more TV white space available in a rural location than in a city centre. Accommodating PMSE use may result in insufficient spectrum being available in locations where it is needed for some applications.

Also, TV white spaces may get congested because several white space devices are trying to access the resources at the same location⁹.

⁹ It could be argued that the lack of availability for this reason is evidence that applications using TV white spaces are successful

3.5.2 Availability of TV white space cannot be relied upon

While DTT use of spectrum is fairly stable over time PMSE use can change quickly and, in some cases, be unpredictable. This means that there is the possibility that a frequency channel that has been available for white space devices for some time could, at any time, be assigned to a PMSE user. The availability of TV white spaces is therefore not guaranteed at specific location. This unpredictability may preclude some services that must have guaranteed access.

3.5.3 TV white space spectrum may not be available indefinitely

As of 2015 there is some uncertainty over whether DTT remains the primary use of the UHF band. If the band were no longer used for DTT this could lead to the disappearance of TV white spaces. However, some countries have stated that DTT will remain an important platform for TV delivery at least until 2030. In addition, several European countries are considering to make the "700 MHz band" (694-790 MHz) available for mobile broadband. European harmonisation of the 700 MHz band is at an advanced stage at the time of publication of this report. The proposed change would involve moving parts of DTT and PMSE services from the 700 MHz band to other frequencies below. The combined effect of allocating 694 to 790 MHz to mobile, and moving the DTT and PMSE users there to the lower parts of the TV band could result in a material change to white space availability¹⁰.

3.5.4 TV white space spectrum may not be authorised throughout Europe

As of 2015 only a few countries have committed to open access to TV white spaces. Other countries are looking at doing so in the short or medium term. Although the details of the implementation vary, most of the countries that have implemented TV white spaces access are relying on a database providing WS devices with the information of the channels to use. However, the local circumstances may lead to different implementations and even different regulatory approaches. Furthermore depending on national legislation, which could exclude for specific reasons the possibility of sharing with DTT in the UHF Band, TV White spaces may not be possible to be implemented at all.

As a result, TV white spaces may not be available in Europe in a harmonised way.

¹⁰ See Ofcom, *Consultation on future use of the 700 MHz band. Cost-benefit analysis of changing its use to mobile services*, 28 May 2014, paragraph 1.10. <http://stakeholders.ofcom.org.uk/binaries/consultations/700MHz/summary/main.pdf>

4 EXISTING CEPT AND STANDARDISATION WORK

4.1 CEPT STUDIES ON REGULATORY ELEMENTS AND OPERATIONAL REQUIREMENTS FOR TV WHITE SPACE

The ECC Report 159 [3] was developed in order to address technical and operational requirements of white space devices in the frequency band 470-790 MHz in order to ensure the protection of the incumbent radio services. In the course of development of this report it was found out that it could be beneficial to continue looking at the matter in order to take into account latest developments in research and industry activities.

CEPT has subsequently developed ECC Report 185 [4] and ECC Report 186 [1] as complementary studies to ECC Report 159. The aim of ECC Report 185 was to complement the ECC Report 159 with additional technical investigations to facilitate development of the regulation for WSDs in the band 470-790 MHz. Importantly this included measurement campaigns which detailed DTT and PMSE protection ratios tests with example WSD technologies. ECC Report 186 reconfirmed a number of the initial conclusions from report 159. In some cases ECC Report 186 went further and was able to provide detailed framework proposals (for example RF coupling gains between victim DTT receiver installations and WSD for a range of reference geometries) based on new modelling techniques and a range of measurement campaigns.

ECC Report 186 assessed the appropriateness of the geo-location technique to provide the required protection to PMSE, RAS, ARNS and the services in the bands adjacent to 470-790 MHz. Initial considerations of the geo-location approach are contained in the ECC Report 159. The ECC Report 186 provides more detailed guidance on general principles and basic requirements for WSDs operating under the geo-location database.

4.2 ETSI STANDARDISATION

ETSI has worked on the use of TVWS since 2011. So far the following work has been completed:

- TR 102 907: Use Cases for Operation in White Space Frequency Bands (published in October 2011) [5];
- TS 102 946: System requirements for Operation in UHF TV Band White Spaces (published in July 2014) [6];
- TS 103 145: System Architecture and High Level Procedures for Coordinated and Uncoordinated Use of TV White Spaces (approved in December 2014) [7];
- TS 103 143: System architecture for information Exchange between different Geo-Location databases (GLDB's) enabling the operation of White Space Devices (WSDs) (approved in December 2014) [8];
- EN 301 598: White Space Devices (WSD); Wireless Access Systems operating in the 470 MHz to 790 MHz frequency band; Harmonised EN covering the essential requirements of article 3.2 of the R&TTE Directive (published in the OJ EU in September 2014) [2].

The next steps that are ongoing in ETSI will cover the preparation and publication of

- EN 303 144: Parameters and procedures for information exchange between different GLDBs [9];
- EN 303 387-1: Signalling Protocols and information Exchange for Coordinated use of TV White Spaces; part 1: Interface between Cognitive Radio System (CRS¹¹) and Spectrum Coordinator (SC) [10].

¹¹ A CRS represents a white spaces device (WSD) or network of WSDs (i.e. a master WSD and some slave WSDs).

4.2.1 ETSI EN 301 598

The harmonised standard EN 301 598 [2] contains a number of technical requirements and procedures to test against those requirements. Devices that meet the requirements of the EN benefit from a presumption of conformity with the essential requirements of article 3.2 of the R&TTE Directive. This article requires that radio equipment is constructed to uses the spectrum so as to avoid harmful interference.

Although meeting the requirements of ETSI EN is not the only route to placing in the market under the R&TTE directive, it is most likely that manufacturers will rely on this standard as a route to show compliance with the Directive. EN 301 598 [2] will therefore be cornerstone for the deployment of WS devices in Europe. Annex 1 presents a summary of the operational model that the ETSI EN relies on and the device requirements in the EN for compliance with the Directive.

4.2.2 Coordinated and uncoordinated use in ETSI work

The ETSI work covers two kinds of usages of the TV WS: in the uncoordinated usage of TVWS each master WSD uses the available spectrum independently, based on operational parameters received from the WSDB, without knowledge of the spectrum usage of other master WSDs. The coordinated usage of TVWS assumes the presence of a coordination function which ensures that master WSDs are coordinated to not cause harmful interference to each other, thus enabling a master WSD and its corresponding slave devices to operate with some predictable quality of service and potentially using dedicated channels. In the coordinated usage of TV White Spaces protection of incumbents is still controlled by a white space database. However, in the coordinated use of TV White Spaces a master WSD will additionally be required to interact with a coordination function.

The ETSI harmonised European standard EN 301 598 does not have device requirements related to coordinated use of TVWS. However, it does not preclude coordinated use either, and hence any master device that supports a coordination function and that complies with the requirements in the standard can be presumed to be in compliance with Article 3.2 of the R&TTE directive. When the standardisation work on the coordinated use is completed, it should be clarified whether essential requirements related to coordinated use of TVWS need to be specified, on a general basis or for certain devices.

4.3 IEEE STANDARDISATION

IEEE 802.19.1 [12]

IEEE 802.19.1-2014 has been ratified, in which the coordination for interference from one WS device to another WS device is provided by coexistence discovery and information server (CDIS), coexistence manager (CM) and coexistence enabler (CE). WSDB can have a set of these entities in addition to the geo-location database. There is however no known implementation in radio products.

IEEE 802.11af [13]

IEEE 802.11af standard was published in February 2014. It is an adaptation of the IEEE 802.11ac Wireless LAN standard, to enable use in the TV White Spaces. It covers MAC and PHY layers and supports 6, 7 and 8 MHz TV channels, for global applicability and allows for concatenation of up to four UHF channels (as shown in the diagram).

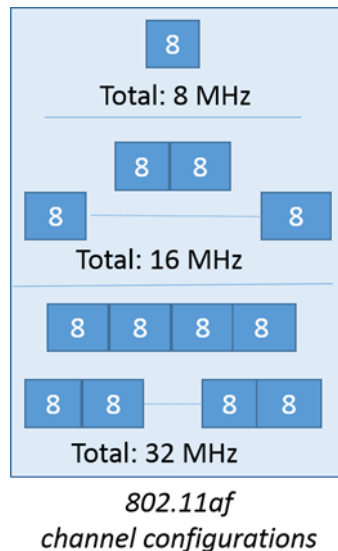

Figure 1: IEEE 802.11af channel configurations [13]

Each (8 MHz) channel supports up to 35.6 Mbit/s. The standard supports up to 4 TV channels bonded and 4 spatial paths, leading to a total maximum capacity of around 560 Mbps. Its politeness protocol is 'listen before talk' – enabling multiple access points to coexist in the same location. Further details at: http://standards.ieee.org/news/2014/ieee802.11af_amendment.html

4.4 IETF STANDARDISATION

The Internet Engineering Task Force (IETF) has developed the PAWS protocol for the communications between WS devices and WS databases. The protocol supports the following functions:

- Devices connect and register with a database;
- Devices provide geo-location and attributes to the database;
- Devices receive in return a list of available white space spectrum;
- Devices report to the database the anticipated spectrum usage.

The work is based on the assumption that the database will be reachable via the Internet, and that radio devices will have some form of Internet connectivity too, directly or indirectly. The specification reuses existing protocols and data encoding formats where possible – in particular HTTPS is used to secure the communications and JSON-RPC request/response objects are used to encode the data exchange.

4.5 OVERVIEW OF TVWS DEVELOPMENTS OUTSIDE EUROPE

In order to learn from developments outside Europe in the field of TVWS regulation, ECO has made a survey which gives information on the situation in Canada, Japan, South-Africa, and the USA. This survey can be found at <http://www.cept.org/ecc/topics/geolocation-databases> in section 'Information related to geo-location database regulations (TV WSD) outside of Europe'.

One of the reasons to provide this survey via the web is that the situation outside Europe is also still very much 'under construction' and so the various regulatory frameworks are not stable yet. Another finding worth to mention is that the survey illustrates the fact that different circumstances indeed lead to different implementations and even different regulatory approaches.

4.6 DYNAMIC SPECTRUM ALLIANCE

The Dynamic Spectrum Alliance has developed rules focussed on enabling licence-exempt access to the TV white spaces. Information is provided on its work is provided in ANNEX 3: of this report.

5 DEVICE AUTHORISATION

The notion of “white space” reflects a general concept that does not fit well within the regulatory regimes commonly used. In this report, the definition of “white space” from CEPT Report 24 (June 2008) [14] is used: White space is a part of the spectrum, which is available for a radiocommunication application (service, system) at a given time in a given geographical area on a non-interfering / non-protected basis with regard to primary services and other services with a higher priority on a national basis.

This definition actually does not tell what would be the applicable “authorisation regime”, which could be either “general” or “individual”. It just stipulates the hierarchy status of WSD with regard to incumbent usage that is deemed to be protected. The effective “authorisation regime” will depend upon the application, the frequency band, the circumstances and national policy. For instance, PMSEs are typical examples of “white space” applications. In some countries, radio microphones in the 470-790 MHz band are operated under an individual licensing regime (i.e. a specific channel is assigned to an individual user) in all circumstances and users and may be subject to licensing fees. In other countries, individual authorisation may apply only during “special events” and the baseline rule is “general authorisation”. On the other hand, wireless video cameras are commonly used under “individual authorisation regime”.

Radio-microphones share the band with DTT, and occupy the radio resources that DTT does not use at a given location. Therefore they can be seen as white space users with regards to the primary user of the band which is DTT.

5.1 GENERAL PRINCIPLES

Article 5.1 of the Authorisation Directive stipulates that “Member States shall, where possible, in particular where the risk of harmful interference is negligible, not make the use of radio frequencies subject to the grant of individual rights of use but shall include the conditions for usage of such radio frequencies in the general authorisation”.

ECC Report 132 [11] provides useful guidance on regulatory regimes based on the general authorisation principle. This report reviews the various terminologies that are commonly used to qualify the regulatory regimes, and shows that practices in various European countries reflect different interpretation of the terminologies. The report suggests some high level guidance on when general authorisation is appropriate:

- individual frequency planning and coordination (or individual frequency assignment) is not necessary;
- use in all parts of the country is possible;
- user individualisation is not necessary;
- the use of a frequency or of a frequency band is possible by a number of users within a particular area;
- spectrum is available on a long-term basis.

Although ECC Report 132 recommends using the terms “individual authorisation” and “general authorisation”, the terms “licensed” and “license exempt” use are also widely used. ECC Report 132 defines a licence exempt regime as “a general authorisation regulatory regime under a well-defined set of conditions that does not include any provision for registration and/or notification”. The Report on the “Collective Use of Spectrum” commissioned by the EC provides additional and useful characterisation of licence exemption: No individual authorisation or co-ordination is required and no fee payable for using the spectrum. Access is regulated solely by adherence to pre-defined regulatory conditions.

In addition, it is useful to consider light licensing which sits somewhere in between licence exemption and licensing. Light licensing is generally associated with registration of users and with some level of frequency coordination. A definition can be found in the Licence Exemption Framework Review from Ofcom UK: Light-licensing is a mechanism whereby the users of a band are awarded non-exclusive licences which are typically available to all, and are either free or only has a nominal fee attached to them. There may be further obligations associated with the provision of a licence such as the need to register the location of any transmitters and possibly to coordinate their deployment with other registered users.

The following table, taken from ECC Report 132 [11], provides a useful summary of these concepts:

Table 1: Differences between various regulatory options

Individual authorisation (Individual rights of use)		General authorisation (No individual rights of use)	
Individual licence	Light-licensing	Licence-exempt	
Individual frequency planning / coordination. Traditional procedure for issuing licences	Individual frequency planning / coordination Simplified procedure compared to traditional procedure for issuing licences. With limitations in the number of users	No individual frequency planning / coordination Registration and/or notification. No limitations in the number of users nor need for coordination	No individual frequency planning / coordination. No registration nor notification

5.2 AUTHORISATION REGIME FOR TV WSD

The key test for suitability of a general authorisation regime is in Article 5.1 of the Authorisation directive – is the risk of harmful interference negligible? In the case of TV WS, this is ensured by two elements:

- i) Database assisted operation: the database will carefully choose the radio resources for a WS device in order to avoid interference to incumbents
- ii) Devices compliant with requirements such that they will only radiate according to the parameters provided by a database. The starting point for this is the R&TTE directive, which requires that equipments put in the EU market must not cause harmful interference. The most common route to achieve this in practice is through compliance with an ETSI Harmonised Standard. For devices operating in the TVWS in Europe, Harmonised Standard EN 301 598 [2] contains the requirements for operation under the control of a database.

Once that the key test of mitigation of harmful interference has been satisfied, it is useful to consider as well whether the characteristics of the spectrum resource made available, and the uses and applications that stakeholders have suggested, are in line with the usual scenarios for licence exemption:

- The applications that have been put forward would rely not on large scale national network providers but rather on small scale networks deployed for instance in homes or locally. Furthermore, these uses may be largely geographically disparate and could be engineered so as not to compete in their demand for spectrum. For example, agricultural, industrial, campus and community networks would tend to operate in different areas and may not therefore be rivals for the same spectrum;
- If the applications described above take hold, it is possible that large numbers of WS devices are deployed in particular for IoT applications and for consumer use. It would not be feasible in practice to issue individual licences to each users;
- The “white space” concept is by nature “opportunistic”, which implies that no guarantee can be given on the availability of spectrum for use by WSD. The availability of “white spaces” is subject to the evolution of primary services in accordance with national spectrum policy, and not guaranteed at any specific location. The absence of guaranteed access is a characteristic closer to a general authorisation regime than to a fee based licensed regime. WS users need to understand the consequences of this approach when deciding to invest on the technology;
- It is worth noting however that there are means of reducing the uncertainty about the spectrum available. One element of uncertainty is the interference caused by other WS devices that the database does not know about. This can be mitigated by requiring the databases to share the information about the WS devices and the resources that they use (see section 7.2 for an elaboration of this);
- A key consideration in opening access to TVWS under a general authorisation regime is to stimulate innovative spectrum uses. Of course it is not possible to predict what innovative services may emerge but the UK trials and the US experience have already shown some applications that were not thought about when TVWS use was first hinted.

It is also useful to compare the proposed general authorisation of TVWS with existing general authorisation regimes. In a conventional Short Range Device license-exempt regulation, the “conditions of use of the spectrum” are explicit and stable. Under the concept of TV WSD using geo-location databases, the knowledge of the “conditions of use of the spectrum” is achieved by consulting a WSDB. The highly flexible approach together with the need to ensure that radio equipment operates in accordance with the specified rules implies that only this spectrum access mechanism (i.e. consulting a certified WSDB) can be permitted.

Overall, these considerations suggest that a general authorisation model is adequate for TV WS, and likely to achieve efficient use of spectrum. It is worth noting however that the database assisted management of spectrum is, in practice, more close to a light licensed model than a pure licence exempt general authorisation. The databases hold detailed information about each device, and carefully assign radio resources to avoid interference to incumbents. This is, in all but its name, a regime of frequency coordination. Therefore, although the spectrum regulator does not issue individual licences, the approach of assignment of frequencies is very similar to a regime of individual authorisation.

5.2.1 General authorisation

This section provides a set of principles that a NRA may want to consider when making regulation to allow access to the TVWS under general authorisation, in particular under a licence exemption regime where users are not required to obtain any form of licence from the NRA.

- No interference, no protection. WS devices must not cause interference to incumbents, and cannot claim protection from interference coming from incumbents;
- WS devices must only contact, for the purposes of operation in TV WS, a database that has been approved by the NRA with jurisdiction over the territory where the device is located. This is a requirement in ETSI EN 301 598 [2], and it is consistent with one key requirement in ECC Report 186 [1] which is that “WSD may only transmit in the territory of a country if it has successfully discovered a geo-location database approved by the NRA”. The list of approved databases is made available by the NRA on the internet;
- WS devices must only operate according to operational parameters that have been provided by an approved database. This is the requirement to prevent interference and it is the cornerstone of geo-location assisted operation – the database calculates parameters according to precise rules provided by the NRA, and the device’s transmissions comply with the parameters;
- It must not be possible that the user modifies or tampers with the hardware or software settings of the device related to the exchange of parameters with the database, or the parameters themselves. Regulators are particularly concerned with the possibility that unqualified end users gain access to the configuration of devices, because incorrect configuration could result in the WSDB providing operational parameters that do not protect the incumbent users in the proximity. This requirement notably precludes that the user of the device inputs device parameters such as location manually into the devices;
- Master devices must have geo-location capability. The location of a slave device can be inferred from the location of the serving master, but master devices must be able to provide their location to the database;
- No WSD has priority over the others. A WSDB must provide operational parameters to WSDs on a non-discriminatory basis i.e. any device of the same category at a specific location and time should be allowed to use the same spectrum. It is possible however that the database, as part of value added services arrangement, informs the device which subset of channels presents better characteristics, for instance in terms of incoming interference from incumbents or from other WS devices. These arrangements are outside of the basic licence exemption regime and may be set up by databases and device operators;
- Multiple databases must calculate the same operational parameters. If a device, with given technical characteristics and location, makes a query to multiple databases then it must get the same response from all (in the absence of value added services). This would help making sure that no WSD is prioritised over others. It also prevents that a particular database becomes preferred because it provides better availability than its pairs, which could result in a race to the bottom between databases;
- Devices must access the database directly i.e. there must not be an intermediate node that relays information from devices to databases. This is to prevent the scenario where a rogue entity, sitting between a device and the WSDB, relays incorrect information to the device;
- ECC Report 186 [1] defines “translation processes” for protection of existing services that can be used as guidance, but beyond that there are a number of aspects where the NRA can take its own view. The NRA has some leeway to specify how the databases must calculate parameters. For instance,

databases could either assign one specific channel for devices to operate in, or instead inform the devices of the available channel (with regards to incumbent usage) at a specific location and time, and let the devices decide on what channel to use.

The first four elements provide the basis for operation and it is unlikely that a NRA would omit them from their rules. On the other hand a NRA may take a view on how strictly the other elements need to be enforced. In any event, devices that are compliant with the ETSI EN 301 598 [2] will behave according to the high level principles outlined.

Finally, it could also be questioned whether this single possible method to get knowledge of the “conditions of use of the spectrum” (i.e. WS devices must contact a database that has been approved by the NRA) under the general authorisation model can be subject to fees charged to the end user. National administration may have to investigate whether the service consisting of providing knowledge on the usage of the “public domain” can be charged under such circumstances (NB: this concern does not apply in the context of “individual authorisation” where the “licensing fees” can obviously compensate for the cost incurred in developing the system).

5.2.2 Individual authorisation

There could however be some new applications for which the delivery of an “individual right of use” could be justified in accordance with the authorisation directive. Two scenarios would justify such approach:

- Market demand for devices which would cause interference if used under a general authorisation regime;
- Introduction of priority of access for certain WS devices.

These scenarios are considered below.

5.2.2.1 *Devices which would cause interference if used under a general authorisation regime*

There may be demand for devices / applications which are not fully compliant with the requirements for licence exemption, i.e. do not support all the requirements of the ETSI standard. One example of this could be professionally installed devices which, for cost or design considerations, could fail to meet requirements of the ETSI standard such as:

- Devices are manually configured i.e. the installer manually input parameters such as location or antenna characteristics.
- Master devices do not communicate with an approved database directly, but instead through another entity such a network control unit or a radio resources manager.
- Master devices that do not have geo-location capabilities – the location is provided to the device or the database by the installer.

Experience from the US and the UK suggest that there is interest in devices of these types. However they would be in breach of the ETSI standard and, more importantly, present some concerns from the perspective of harmful interference if allowed under a licence exemption regime. A regime where such devices are allowed but require a licence to be operated provides better control to the regulator than plain licence exemption, as the regulator can easily identify the WS user if interference to incumbent appears. Also, the requirement to obtain a licence would act as a hurdle to mass market deployment, and hence avoid – to some extent – that unqualified operators deploy the devices.

Under this regime, the licensee would not necessarily be better off in terms of access to spectrum than under licence exemption - access would still be on a non-interference, non-protection basis and on equal grounds as licence exempt devices. The licence merely allows the use of equipment which is excluded from the licence exemption regime.

5.2.2.2 *Priority access*

The opportunistic nature of the usage of the TV White Spaces does not support without employment of specific measures the deployment of services that require provisioning of QoS as there is uncertainty about the availability of spectrum resources and no protection from harmful interference from other WSD's. For example the utility companies would typically need reliable and stable connections for their smart metering applications. Employment of the coordinated use of TVWS could offer certainty for the availability of the required amount of spectrum and protection from harmful interference. Another example of an application that requires providing QoS may be Wireless Internet Service Provision.

Spectrum regulators may consider that there is value in allowing access to TVWS at some level of quality of service, so that if access to radio resources is requested by several WS devices concurrently then those devices with a higher quality of service requirement get priority (but remain below the current incumbents). Another aspect would be the sufficiency of available White Space spectrum.

Taking into account the definition given for WSD, one practical option could be to identify such newly authorised uses as new "incumbents". Another option could be to create a second, high priority tier of WS use above the general authorisation tier. This will require that the regulator defines rules for the coexistence of WS devices so that higher tier devices do not get interfered. Access to the higher priority tier would be through a licence, which most likely will carry a fee related to value of the WS radio resources that the licensee is securing.

6 WHITE SPACE DATABASE POLICY AND PROVISION

A spectrum management system that relies on database queries to assign resources – frequencies and powers – presents policy and implementations challenges to a NRA. Some of the questions to be considered are:

6.1 WSDB FUNCTIONS

This section details the functional blocks required to provide to WS devices the parameters that specify the available radio resources. The section also looks at the issues that a regulator will have to consider in order to decide which organisation should take responsibility for each of these blocks. The chart below outlines the process:

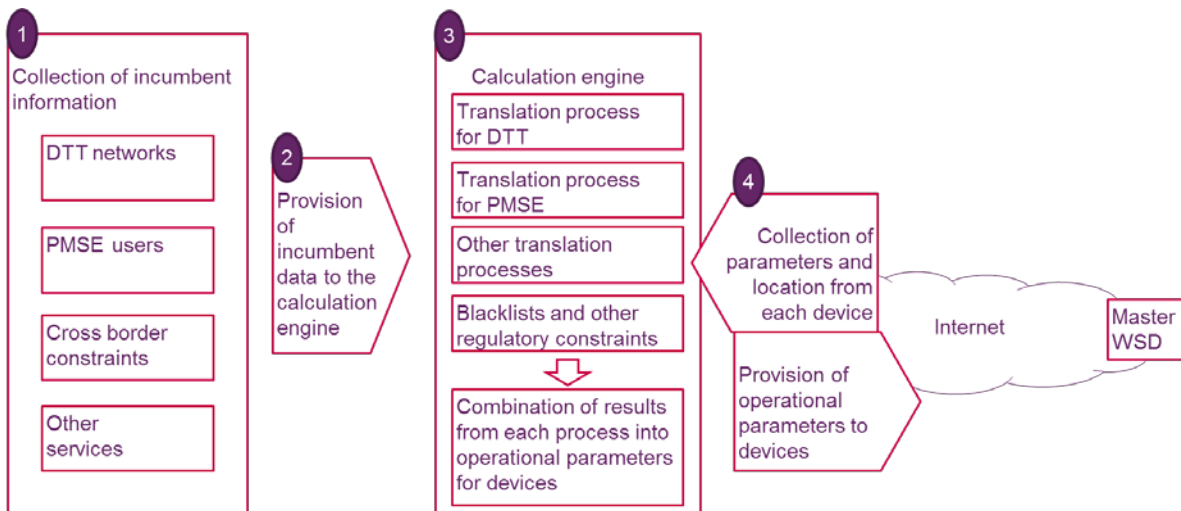

Figure 2: Block diagram outlining possible regulatory considerations

6.1.1 Collection of incumbent information

The first step is to gather the details of the incumbents' usage. There are several aspects that can make this process complex. First, incumbent information may not be available. For instance in some CEPT countries PMSE access is licence exempt and unregistered, hence its actual spectrum usage is unknown. The lack of such information is a key challenge in protecting PMSE against WSD. One example presented in ECC Report 186 [1] of trying to address this problem is to give users an easy overview of the spectrum available for PMSE in the band 470-790 MHz and to allow PMSE users to register their usage and thereby claim protection from WSD. The use of the band by the rest of users is generally well documented and hence the availability problem does not appear

A second question is who holds the spectrum usage information. In the simplest scenario the information will be held in the databases of the spectrum regulator. In other cases the regulator might have some but not all the data, or not to the level of detail needed for the protection calculations. A third scenario could be that the incumbents or a third party, perhaps appointed by the NRA, manages the frequency planning and hence hold the data.

It should be relatively straightforward for the NRA to share with a WSDB operator the incumbent information that the NRA owns, although there may be privacy aspects to consider when this information contains location data. On the other hand, when the information belongs to a third party, the incumbent user for instance, it may be more difficult to require the user to share. In particular, there may be considerations about intellectual property embedded in the dataset – such as antenna design for instance.

Finally, the task of collecting data may involve a cost that is non-negligible. It may be necessary to extract the relevant information from the existing data repositories and to get it in a shape that is useful for the calculation engine. If the collection of data is recurrent – for instance because new assignments are made on a regular basis – then it may be necessary to set up automated processes to generate and get the data ready. If the incumbents are required to incur on these costs, it may be necessary for the regulator to establish a regime to compensate them.

6.1.2 Provision of incumbent information

The datasets need to be made available to the computers that will carry out the calculations. The key considerations in this area are on the main related to implementation rather than policy. A set of data transfers mechanisms have to be agreed between the parties – the databases, the regulator, the incumbents or third party band managers. Some of the issues to be considered are:

- How frequently a dataset is updated, and how quickly does the database need to take the update into consideration in its calculations;
- What is the size of the dataset;
- What are the requirements for the transport method, notably with regards to security – authentication, integrity, confidentiality – and reliability;
- Are there data protection considerations or other legal constraints that may reduce the technical options? For instance, when the original data is not held by the regulator it may be necessary that the data passes through the regulator before it is made available to the entity carrying out the calculations.

6.1.3 Calculation engine

The calculation engine translates the information on incumbent services and the technical characteristics and location of the WS device into a list of allowed frequencies and associated transmit powers for devices. ECC report 186 [1] provides guidance on some of the approaches for the technical algorithms to be used in the translation processes to protect the services currently using the band in the CEPT countries, namely DTT, PMSE, Radio Astronomy and Aeronautical Radio Navigation, and the services in adjacent bands. By applying these or similar algorithms the calculation engine will determine the allowed channels and powers for WS use. In addition, the NRA may want to add additional constraints to the calculation process, such as a reduction in available power levels in a particular region or for a specific device. In all, the translation calculations can be computationally intensive.

The results of each translation calculation are merged and single power level figure is identified for each channel – normally the figures are the minimum of the values resulting from the translation processes for each channel. The dataset with this information and with additional parameters such as the time validity is the information that will be facilitated to the WS device.

A key consideration here is whether the regulator itself should carry out one or more of the translation processes. If so, the regulator would provide a dataset of results to the databases – in the form of powers and channels available for WS usage at all points in grid covering the country. This could be justified for instance for the DTT translation process: the DTT co-existence framework for calculating WSD powers may require a significant number of complex calculations, often using data which is sensitive to the incumbent DTT broadcasters.

For some NRAs it may be more practical to divide the overall responsibilities of the White space database into the following: The NRA enters a local agreement with the DTT network operator or operators where the NRA requests and is given a selected set of DTT network planning data. The NRA then independently calculates WSD power levels for each UHF channel on a national basis based on this underlying DTT data and publishes the calculated WSD operating characteristics to all relevant commercial WSDB providers. Commercial database providers would then be required to further add any protection requirements for PMSE services.

The NRA could consider this approach a necessary step, to ensure that the complex DTT co-existence calculations are consistently calculated, and common WSD powers (based on the DTT protection requirements) are used for all base-line calculations by all commercial database operators. In general DTT

platforms are relatively stable in their nature, therefore the burden imposed on the NRA will be low and the DTT co-existence calculations may only have to be conducted (approximately) on an annual basis.

NRAs should account for the risk associated with potential cumulative effect of WSD interference to incumbents when defining the rules to be implemented in the calculation engine (e.g. by setting adequate margin).

6.1.4 Communications with the WS devices

Once the operational parameters have been calculated then they can be sent to the device. The communications between devices and the calculation engine will normally be over the internet – although it is possible that organisations set up WS networks using an intranet – and will make use of proprietary protocols or a standardised protocol such as IETF PAWS. This step consists of managing an internet database that could potentially serve millions of requests from devices, and it is expected that it will normally be the responsibility of a database organisation - without direct involvement of NRA.

6.2 OPTIONS FOR PROVISION OF WSDB SERVICES

The previous section outlines the functional elements that are required to provide operational parameters to WS devices. A key policy decision for an NRA is which organisation is going to carry out those functions. As noted above, some are likely to be within the remit of the NRA itself - for instance procuring the information about incumbent usage. Furthermore, some NRAs already perform automated (or semi-automated, i.e. with some human intervention) licencing through their websites. This requires skills and resources that are not very different from those necessary to implement and run a WSDB. However, NRAs may also prefer to rely on external organisations for the WSDB tasks.

This section looks at the options that the NRA could have for this, and the elements that a NRA would normally consider when looking at this issue. One may look specifically at the following 3 alternatives:

- 1 The NRA manages the WSDB;
- 2 The NRA outsources the WSDB function;
- 3 Commercial WSDB provider(s).

6.2.1 Model 1 - the NRA manages the WSDB

The NRA develops controls and finances all the WSDB functions, much like an online licensing system. The NRA may outsource some IT tasks – writing the software that implements the algorithms, or the hosting of the site – but it is responsible and accountable for the operation of the system. It also decides what services the WSDB provides and how much end users are charged. This model has the following strengths and weaknesses:

Strengths

- The NRA is in full control of who accesses the spectrum, what radio resources each user is allocated, how much is charged. The NRA can adjust any of these to its policy requirements – a commercial entity would put its business needs first and these may not align with the policy considerations of the NRA, in particular if the latter takes into account social value considerations
- There is not a business operation risk that could affect the provision of services to the end users. A commercial WSDB may fail as a business and cease to operate, leaving its end users stranded.
- There is no conflict of interest. A commercial WSDB whose customers are WS device operators might be less careful with the WS availability calculation, or deliberately miscalculate it, in order to let its customers gain access to greater resources. Even if this was mitigated, incumbents will normally feel more comfortable with a scenario where the responsibility to manage WSDs resides entirely with the NRA.

Weaknesses

- It requires substantial involvement and financial investment from the NRA. The NRA may not have the technical, managerial and financial capability to develop and run what is, essentially, an internet database;
- It is unlikely that the NRA can be as innovative and as reactive to the end user needs as a commercial company. The NRA, as a public sector organisation, lacks the key private sector drive for innovation – the search for profit. This would be exacerbated by the fact that, under this model, there can be no competition in the provision of database services, which is often a key driver of innovation and cost reduction in markets.

6.2.2 Model 2 - the NRA outsources the WSDB function

The NRA specifies in detail the tasks that the WSDB provider will carry out – notably the services that the WSDB must provide to end users – and how much end users are charged. If the end users are charged a fee, this revenue goes to the NRA directly. The WSDB provider gets its revenue from the NRA – essentially the NRA contracts a service with the WSDB operator consisting in providing WS availability to WS devices. This model has the following strengths and weaknesses:

Strengths

- This outsourcing model has the advantage that it requires less investment from the NRA in terms of use of internal technical and management resources than the previous model. Financially, it may appear less attractive as the NRA will be procuring a full service. However, a competitive procurement process can go some way to mitigate this – potential providers would be bidding on the basis of who can provide this service to the NRA at lowest cost;
- The model maintains the control of the NRA over the conditions for access to spectrum, and hence can support policy goals such as universal and free access.

Weaknesses

- This approach still requires an important financial outlay from the NRA. A competitive tender of the project will mitigate the costs, but the tender is likely to include evaluation criteria other than cost;
- From the perspective of the subcontractor, the customer is the NRA. It does not obtain revenue from the end users, so it does not have an incentive to introduce new services or to seek more users. Services to the end users are specified upfront by the NRA. It may be possible to introduce clauses in the contract that allow for new services, but this will be via the NRA and not in a result of a commercial relation between the provider and the end user.

It is possible to enhance this model to address its drawbacks. This is how it could be done: the provider will be required to provide certain basic services under the conditions set by the NRA, but it would be allowed to leverage its platform to introduce new services and to charge for them. The subcontractor still charges the NRA to provide the basic service, but the NRA would normally see lower bids in the competitive tender as providers have an opportunity to develop a second revenue stream.

6.2.3 Model 3 - commercial WSDB provider(s)

The NRA authorises commercial providers to operate as a WSDB. The NRA specifies a minimum set of requirements for the WSDB(s) and has enforcement role in with regards to those requirements. The database operator decides on what services to provide, which WSD users to serve and how much to charge according to its business strategy.

The NRA will not pay the WSDB to perform the tasks. In fact, it may decide to charge it instead. The NRA may want to recover its own costs, which will arise from tasks such as the process of authorising a WSDB, or developing and running the infrastructure to provide the WSDB with the incumbent data on an ongoing basis. In this scenario it could be expected that the providers would be willing to bid to become a WSDB, since they will make a profit from serving the end users.

Considering the above, the NRA needs to decide whether: 1) it does not charge the WSDB at all, 2) it charges the WSDB to recover its costs, or 3) it authorises the WSDB following a competitive process where the provider willing to pay more gets the right to operate. The choice between these options will be driven by

a number of considerations, the main one being whether a single or multiple WSDBs are authorised. This specific question is explored in the section below.

Strengths

- The NRA's costs in this scenario arise from the WSDB authorisation process, ongoing monitoring of WSDB compliance, and the collection and provision of the incumbent information. These will be substantially lower than the costs involved in the previous models and, depending on the legal framework under which the NRA operates, could be recoverable via a cost-based charge;
- Regulatory intervention is kept to the minimum, i.e. to ensure that incumbents do not suffer interference. Beyond that, WSDBs providers have complete freedom to develop their service offer. The market of WS services would develop free of regulatory constraints.

Weaknesses

- The NRA has limited control over who accesses the band, and it may not be possible to guarantee policy goals such as universal access (as it is currently available in the 2.4 GHz licence exempt band). WSDBs may decide that serving certain users is not profitable, and evolve into closed systems i.e. serving only a few customers;
- This will not be the best option if there are doubts about the technical competency of the potential providers, or the viability of their business models¹². The NRA may not trust that the candidates will carry out the calculations correctly or that they can put in place the processes and systems to support interference management, or that they can subsist in the long term;
- Another cause of concern is the misalignment of incentives mentioned above. The WSDB's customers are the WS device operators, who benefit from larger access to resources. A WSDB may be tempted to sacrifice protection of incumbents in order to increase the WS availability communicated to its customers. This behaviour can be mitigated if the NRA can credibly threaten to place sanctions against the WSDB out of business if its actions result in interference.

There are ways to address some of these concerns. A NRA with policy goals related to universal access could introduce an additional requirement for WSDBs to offer a free, open to all, basic service. Also, a NRA can allow multiple WSDBs and reduce the barriers to become a WSDB in order to introduce competition. This would normally ensure that, if there is an economic profit in serving certain customers, a provider will take the opportunity. A penalty regime can motivate WSDBs to be rigorous about protecting incumbents. The NRA can also specify the calculation algorithms in detail and put in place a strict qualification process followed by continuous oversight to ensure that WSDBs implement them correctly (at the limit the transactions costs from such an approach may exceed the costs of more directly controlling the WSDB (i.e. model 1 or 2), although other benefits will remain e.g. in terms of innovation or service quality).

6.2.4 Conclusions

In summary, the choice between these models will depend on the relative importance for the NRA of the following key aspects:

- Degree of support of innovation vs. a tightly defined WSDB service;
- ability and willingness of the NRA to incur in costs in support of WS;
- capability of the NRA, in particular technical expertise, to operate a WSDB;
- choice between a framework with an single WSDB or with multiple WSDBs;
- and
- level of risk that the NRA is willing to take about WSDB providers will operating as specified.

¹² Although NRAs may be less concerned about the viability of business models adopted if a vibrant, well-functioning market is established with multiple databases. Exit is an important part of the competitive process and as long as sufficient alternative WSDBs remain in the market, it should not create disproportionate disruption for end users.

6.3 MULTIPLE WSDBS VS ONE WSDB

If the NRA concludes that the WSDB functions should be carried out by an independent, commercial provider – model 3 above – then it will have to consider how many WSDBs it will authorise, in particular whether there will be only one provider or multiple providers. This question is not relevant under model 1, where the NRA decides to become the WSDB itself. Model 2 also seems better suited to a single WSDB scenario where the WSDB can be seen as a subcontractor that provides a service to the NRA for a fee. This is because entering arrangements with multiple providers for the same service would only increase the costs to the NRA with no clear benefit – the NRA will be charged multiple times and will have to manage multiple contractors, but the service to end users will be the same from any of the providers (although this may be less true under the variant to model 2 described above).

On the other hand, a NRA that sets a framework where the WSDB acts as a third party (Model 3 above) will need to consider how many WSDBs to authorise.

This section analyses first the scenario where only one WSDB is authorised. It looks next at a scenario with multiple WSDBs. Finally, it considers whether the NRA should, after choosing the multiple WSDB alternative seek to decide on a fixed number¹³.

6.3.1 Single database provider

Under this model the NRA selects one WSDB operator. The selection process is not considered here, but it could be similar to a competitive award for a procurement contract or for spectrum. The NRA collects data on incumbent usage and then provides this data to the operator. The operator will then pass on to WS devices the radio access parameters, which will be based on the incumbent data

Strengths

- Potential database providers will be more willing to pay to be authorised by the NRA if only one provider could access the data, as it then secures a monopoly in supplying the data to downstream WSDs. From the NRA's perspective, this makes it easier to recoup its costs of data collection and processing;
- Less duplication of databases. Where there is a fixed cost of becoming a database provider, duplication would result in higher costs overall. This is also linked to the potential for economies of scale¹⁴ – where there are likely to be significant economies of scale, a single database provide may be more likely to achieve efficient scale;
- Easier to check accuracy (as only one database to cross check against the central data) and lower costs to the NRA of authorising and 'policing' the database;
- If co-ordination of devices was required, it would be easier for a single database provider to co-ordinate different WSDs to avoid interference, taking into account requests from other WSDs;
 - This is not relevant in the short term – technology can be expected to resolve interference issues at least in the absence of excess demand. It may be relevant if, in the future, high demand for spectrum from WSDs was resulting in congestion and that rationing is needed to promote efficient spectrum use;
- Some business models may only be viable (or may be significantly easier to establish) with one database provider e.g. setting up system to reserve spectrum for some WSDs (linked to co-ordination point above).

¹³ The analysis does not consider whether all authorised WSDBs must provide parameters to all WS devices, or WSDBs are free to choose who they serve.

¹⁴ Economies of scale are where the average cost of production falls as the quantity produced increases. For example, if the database provider has to deal with a high volume of requests from WSDs, it may be worthwhile for it to invest in more sophisticated software which allows it to deal with each request more quickly than if it only received a small number of requests.

Weaknesses

- Restricts competition in the market, potentially to the detriment of efficiency, choice and innovation. Efficiency may be secured to some extent through competition for the market in the bidding process – the provider who bids the most to access the data (or submits the lowest bid to provide the service) is the one who will provide highest value/lowest cost (although this depends to some extent on the bidding process e.g. auction vs. beauty contest). However, this does not guarantee on-going efficiency gains, or other benefits (e.g. choice, higher quality of service) in the same way competition between database providers would;
 - Would competition in the market or competition for the market be more effective in this case? This will depend on the likely size of the market i.e. whether demand will be sufficiently high (relative to costs) to sustain more than one database provider;
- Entering into a long-term contract with one database provider to the exclusion of others may prevent the market from adapting as new information becomes available e.g. may prevent higher value database provider from entering the market with a different business model. Given the nascent nature of the market, it is not clear that the NRA would have enough information to choose the 'best' potential entrant without significant risk of regulatory failure;
 - Extent of this risk depends on the selection process and how prescriptive the contract terms are i.e. how far they restrict the provider from changing its strategy once it has won;
- The NRA will have to regulate the business of the WSDB provider if it believes that it could take advantage of a monopolistic position. This could involve pricing regulation, but also quality of service regulation, and would have a cost to the NRA.

6.3.2 Multiple database providers

Under this model the NRA authorises one or more WSDB operators. The NRA collects data on incumbent usage and then provides this data to the operators. The operators will then pass on to WS devices the radio access parameters, which will be based on the incumbent data.

The revenue of the WSDB operators arises from charging WS users. The operators have freedom to decide on the level of charging, and, more generally, on their commercial proposition. On this basis, they would be willing to enter the business (and even to pay to get authorised by the NRA).

Strengths

- Potential for differentiation to provide more choice and higher value for WSDs e.g. tailor services to cater for specific areas of the market more efficiently
 - Depends on degree WSDs want/need differentiated service (if a 'generic' database is sufficient, this may not develop);
 - Depends on contract terms, which may restrict ability to differentiate e.g. if the NRA gives everyone the same data or has a requirement that all WSDs must get the same parameters;
- Greater incentive for innovation to devise value-added strategies in order to attract customers and be able to charge a premium;
 - However, some business models may be infeasible with more than one database e.g. reservation system/ 'band manager' role harder to establish with multiple databases;
- Even if there are no opportunities to differentiate, WS users will have a choice of providers and this will ensure quality of service (if the service that users receive from a provider is poor, they will have alternatives);
- Greater incentive for efficiency – incentive to reduce costs and ensure spectrum goes to those downstream users who values it most (depending on charging mechanism implemented);
- The NRA does not need to regulate the providers, beyond ensuring protection of incumbents from interference (the consumer interests regarding pricing and quality of service will be guaranteed by competition beyond providers). This results in lower costs to the NRA;
- The NRA needs to ensure that the WSDB providers translate the incumbent information into WS device parameters correctly. This is likely to involve complex algorithms. It will be easier for the NRA to verify that the calculations are done correctly if there is more than one entity implementing the calculations, as it will have multiple points for comparison.

Weaknesses

- Potential for inefficient duplication – if all of the database providers are using the same inputs (data, algorithms), then they could essentially be perfect substitutes. There may therefore not be much value in having more than one;
 - However, competition between databases would still ensure lower prices downstream;
 - If there is free entry and exit, any inefficiency caused by this is likely to be transitory (as if there are too many databases, not all will be sufficiently profitable and so some will exit the market);
- Risk of upheaval/market ‘failure’ – it is unclear how much demand there will be and whether this will be sufficient to sustain more than one database provider. This may mean that providers are unwilling to enter the market, or enter and then are forced to leave rapidly, and so the market may fail to develop;
- Higher enforcement and monitoring costs – these are likely to be proportional to the number of databases in operation;
- Data protection risks – having to share the data with multiple parties may dissuade incumbent licence holders from providing full and accurate information, particularly if certain types of parties (e.g. a licence holder’s direct competitors) applied. Note that this could also be an issue with a single database provider, depending on who that provider was;
 - This risk could be managed through effective contract terms e.g. guaranteeing Chinese walls within the database provider. In addition, the NRA would presumably have the discretion to refuse an application where concerns of this nature were raised;
- A mechanism to deal with coordination of WS devices would be more complex to establish than in the single WSDB case.

6.3.3 Limit on the number of WSDBs

Many of the benefits from having multiple databases arise from the potential this has to generate competition between WSDBs. This prompts the question of how many WSDBs would be needed to derive these competitive benefits, and whether the NRA should limit or encourage entry.

This is highly context dependent – how many WSDBs are needed for effective competition will depend on factors such as barriers to entry, switching costs and the degree of differentiation between providers. In addition, how many WSDBs the market can actually sustain will also be influenced by the number and willingness to pay of end users and the costs of setting up and running a WSDB. Not only are these factors likely to be very different between markets (and difficult to predict while the market is still nascent), but there is also likely to be scope for them to change within a market over time. There is therefore a significant risk of regulatory failure in the NRA trying to judge ex ante the ‘correct’ number of WSDBs.

This suggests that the NRA should not seek to artificially limit the number of WSDBs it authorises, subject to the need to ensure WSDBs will operate to the required standard (e.g. in terms of accuracy in providing information to WS end users). However, this could create high costs for the NRA if it needs to undertake significant pre-authorisation checks on the technical competency of prospective WSDBs, and the number of candidates is high. One option available to the NRA is to make this process as simple and light-touch as possible (while still providing an effective screen). If the cost were overall likely to be burdensome for the NRA (but the incremental cost of each check were relatively low), the NRA could consider charging for this authorisation process. This would both allow the NRA to recover its costs and also could act as a preliminary screening test (as only those who were likely to be authorised may be willing to pay an upfront cost).

However, this would also raise entry barriers and so could deter some potential entrants who would otherwise have entered the market (particularly where the upfront cost was high relative to the expected profits from entry)¹⁵. The NRA will need to balance the benefits of encouraging the development of effective competition against the costs of establishing a competitive market.

¹⁵ This could particularly be an issue where the authorisation process also created costs for the WSDB applicants e.g. through the need to prepare materials to prove their capability to meet the required standards.

6.3.4 Conclusions

The key elements to consider regarding the decision on the number of WSDBs to authorise are the following:

- Competition between database providers will be beneficial to end users, as it is likely to drive innovation and give users greater choice;
- The costs to authorise enforce and provide data to the WSDB would be easier to recoup in a single WSDB scenario. However, the NRA might need to incur additional costs to regulate a monopolistic provider;
- A multiple providers model will have lower risk of regulatory failure in that the NRA would not be attempting to choose the only supplier for a nascent market;
- A single database model may have some efficiency benefits, and may also provide greater certainty for potential database providers seeking to bid to enter;
- A regulator regime where WS devices will be coordinated is easier to implement with a single database provider;
- If multiple WSDBs are authorised, the NRA should not seek to decide which the right number is. This may carry high management costs to the NRA if the number of candidates is high. The NRA could recover the costs by charging for the authorisation process.

6.4 CHARGING AND COST RECOVERY CONSIDERATIONS

6.4.1 Introduction

Unlike traditional licence exemption, making TVWS available requires a significant infrastructure to be in place. This section looks at some of the issues around the costs involved and who should bear those costs. The analysis is based on a model that requires the following data exchanges between participants:

- The incumbent spectrum users tell the NRA what spectrum they are using and the characteristics of the use.
- The NRA then makes this information available to database provider, along with an algorithm to determine what of the available spectrum is suitable given the characteristics of the WS user and the need to minimise the risk of harmful interference.
- The database provider will use this information to tell each WSD user which radio resources are available. It may also provide value added services for an additional fee.

Flowing from these exchanges of information, the NRA and incumbents will face costs from collecting, aggregating and updating data on available spectrum for use by WSDs. The NRA will also incur costs in establishing and updating the algorithm and monitoring the accuracy of the third party database/s used by WSDs. Although making spectrum available to WSDs should not significantly increase the risk of interference to the licence holder if the coexistence framework is done right, there may nevertheless be an increase in the enforcement costs to the NRA of detecting and resolving interference. Finally, the database provider/s will also incur costs in setting up their systems and responding to WSDs' requests.

An NRA should consider who ultimately bears the costs of making spectrum available for WSD use, i.e. should incumbents, NRA or database providers be able to pass these costs on the end user. That is:

- 1 Whether incumbents should be reimbursed for providing information on available spectrum and if so, who should pay for this;
- 2 Whether the NRA should recover its costs of exchanging data, setting up the regulatory framework, monitoring WSDBs and managing interference;
and
- 3 Whether database providers should be able to charge end users for their services.

The NRA should consider cost recovery at each stage in the provision of information, although it is likely that the appropriate model for setting charges at each stage (including no charging) will be closely linked. This section provides first a framework for considering charging, and then applies the framework to these three steps.

The analysis in this section abstracts from any legal or policy considerations as to the charging regime and sets out a largely economic assessment of the factors which a regulator will need to take into account.

6.4.2 Charging framework

A long-established framework for analysing issues around charging and cost recovery in regulation is in the form of the six principles of cost recovery¹⁶. This framework provides a useful starting point for considering charging by each of these sets of parties. The six principles of cost recovery are:

- 1 Cost causation: costs should be recovered from those whose actions cause the costs to be incurred;
- 2 Cost minimisation: the mechanism for cost recovery should ensure that there are strong incentives to minimise costs;
- 3 Effective competition: the mechanism for cost recovery should not undermine or weaken the pressures for effective competition
- 4 Reciprocity: where services are provided reciprocally, charges should also be reciprocal.
- 5 Distribution of benefits: costs should be recovered from the beneficiaries especially where there are externalities; and
- 6 Practicability: the mechanism for cost recovery needs to be practicable and relatively easy to implement.

The following sections look at the applicability of these principles to the three charging questions presented above.

6.4.3 Costs incurred by the incumbents

6.4.3.1 Cost recovery considerations

Cost causation: The costs to incumbents are not caused by their activities, but by the activities of database providers and WSDs. The cost causation principle therefore suggests that the costs should not be borne by the incumbents, but by the downstream beneficiaries in the WSD market. However, in some cases costs will not be imposed on the incumbents (for example where the NRA already holds the information on what spectrum is available). There would be no reason to compensate them in such case.

Distribution of benefits: Benefits of use of TVWS accrue to those operating in the WSD market and not the incumbents. This suggests that the costs should be recovered from the WSD market, as this will ensure there is not inefficiently high demand from WSD users (as may arise if they do not face all the costs of their demand).

If the incumbents have some control on the amount of TVWS spectrum that is made available, there is a risk that they make little spectrum available if they cannot recover the costs they incur. Incumbents may also need an incentive to make as much spectrum available as possible

¹⁶ The six principles were first set out by Oftel (UK Ofcom's predecessor) in its submission to the Monopolies and Mergers Commission in July 1995 and they were adopted by the MMC in its report, *Telephone Number Portability: A Report on a reference under s13 of the Telecommunications Act 1984* (MMC, 1995). They have subsequently been used by Oftel and Ofcom in a range of contexts, including dispute resolution and market reviews.

This could be achieved through linking payment to the amount of spectrum provided (on top of the cost incurred in specifying what is available). However, the NRA would need to ensure this doesn't undermine the incentive to use the spectrum for its primary purpose i.e. the purpose for which it was allocated to the incumbent.¹⁷

Cost minimisation: The incumbents incur the costs and so are responsible for keeping them at efficient levels. However, if they recover those costs in some way, they would not have an incentive to keep them as low as possible. The NRA may have to intervene in some way if it believes that the incumbent is generating and providing the data in an efficient way.

Effective competition: If incumbents cannot recover their costs from the WSD market, there are two possible concerns which may arise in relation to competition:

- a) Is it likely that the costs would be so significant as to undermine the incumbents' business and force them from their 'primary' market?
- b) Is it likely that costs would fall equally on all incumbents (i.e. would some face higher costs than others e.g. if they have more variable use of spectrum and so need to update their data more regularly)?

Practicability: it is likely to be more practical for the incumbent to recover its costs from the NRA rather than from database providers or WSD users more directly (unless database providers/WSD users establish some direct commercial relationship with incumbents for the use of their spectrum). There could be a number of mechanisms for this, such as reduced spectrum fees or a charge to the NRA for data (the NRA should then be able of recovering this cost downstream).

6.4.3.2 Conclusion

This suggests that NRAs should consider allowing incumbents to charge to recover their costs, although there would need to be a mechanism to ensure those costs are efficiently incurred. The NRA may also want to let the incumbents recover some of the value of the spectrum they are making available, but this should not undermine the incentive to use it for its licensed purpose where this gives higher benefits.

6.4.4 Costs incurred by the NRA

6.4.4.1 Cost recovery considerations

Cost causation/Distribution of benefits: The costs are incurred for the benefit of a specific group of end-users (WSD users). It would therefore be efficient for these users to bear the costs.

Cost minimisation: It will be for the NRA to ensure its costs are efficiently incurred (although some costs will depend on the behaviour of other participants, for instance the costs of monitoring the accuracy of the databases will depend on the database providers).

Effective competition: If database providers and/or WSDs face the cost of making the spectrum available this should help to prevent inefficient market entry (too many database providers/WSDs). However, the costs should not be prohibitively high to discourage efficient entry so as not to undermine efficient competition (e.g. if the costs are too high, fewer database providers may be sustainable).

Practicability: In a licence exempt regime, it would be difficult to charge individual end users. The NRA can instead specify charging mechanisms in its database authorisation mechanism. In any case, efficient charging must ensure that there isn't over-recovery and that the charges match the underlying cost structure.

¹⁷ It is assumed that, since the spectrum has been allocated for use by the incumbent, this is the higher value use of the spectrum.

6.4.4.2 *Additional considerations*

There are some possible situations in which it may be justified for NRAs to absorb the costs rather than passing them onto database providers, which is discussed below. NRAs would need to assess whether these circumstances held in their particular case.

Proportionality: It may be disproportionately costly to develop and implement a charging mechanism, in which case it may be more practical for the NRA to absorb the costs. This will depend on the level of costs of gathering the data compared to the cost of implementing a charging mechanism.

Positive externalities:¹⁸ A situation where not all of the benefits of TVWS use accrue to the WSD users would normally result in a level of TVWS use that is below the socially optimal level. A way to reach the socially optimal level of use would be that WSD users pay less than the full cost, as this would increase demand. However, this approach has to be carefully tested as it is not always clear that there actually is a positive externality or that reducing the end user costs is the best way to deal with it. For instance, it is likely that TVWS use would be a means of attaining some external benefit rather than providing the benefit in itself. It would normally be better to subsidise the output that provides the benefit than to charge less for the use of the TVWS spectrum (which is a particular input to getting that benefit), because it will not risk distorting the decisions in how to reach that output.

Increased competition in downstream markets: This is a form of positive externality, as the increased competition from having other forms of providers benefits all consumers in the market, not just those who buy from the WSD provider. However, the NRA would need to be satisfied that there would be significant enough incremental competition benefits in the markets where WSDs are likely to be deployed for this to be a reasonable justification.

Hindrance of development of the market: a large charge on WSD users or on WSDBs could harm the development of the market if it was so large (relative to the size of the market and willingness to pay of WSD users) that database providers would not be able to profitably enter the market. However, this would suggest that the value of WSD services is less than their costs and so it may not be efficient for the market to develop anyway. Secondly, the NRA could decide to take on its costs for a period of time at the start of TVWS operation and to reserve itself the option to introduce a levy once the use of the band becomes established. The argument for this would be the support for innovation and for a nascent market.

6.4.4.3 *Conclusion*

This suggests that NRAs should consider recovering its costs from WSD users (or more practically from database providers) to ensure an efficient degree of use, but there would need to be a mechanism to ensure costs are efficiently incurred. The NRA should also consider how the structure of charges would affect efficiency, given the structure of costs. While there are possible arguments for NRAs to absorb these costs, it will need to consider how compelling these are given the circumstances in their markets.

¹⁸ A positive externality is where the actions of a private individual spill over onto others, creating an external benefit which is not taken into account in the individual's decision making.

6.4.5 Costs incurred by the WSDB provider

6.4.5.1 Cost recovery considerations

Cost causation/Distribution of benefits: The databases are there primarily for the benefit of WSD users and so ultimately they should pay for them. This suggests that WSD users should be charged for access to the data.

However, as set out above, in some cases WSD users may provide positive externalities. In this situation, not all of the benefits accrue to the WSD users, and so there may not be enough use by WSDs (compared to the socially optimal level of use). This would suggest that there should be some intervention to reach the socially optimal level of use (although as argued above it is more questionable whether this should be directly tied to the use of WSDs if this is only one possible way of providing the service).

Cost minimisation: Competition between database providers would ensure their costs are competed down to the efficient level, both in the short term and over time, and also provides an additional spur to add value and increase quality of service. Having a single database provider chosen through a competitive process would ensure costs are initially at the efficient level, but would not guarantee on-going efficiency gains over time. Therefore, there would be fewer issues with cost minimisation if the database market is competitive.

Effective competition: The costs passed on to WSDs should not be so high as to prohibit efficient deployment. They should also not be set so as to unduly discriminate between different WSDs such that competition between them is distorted. However, competition between database providers might prevent this (e.g. a database provider may be able to profitably provide services to a WSD user who was being discriminated against by another database provider).

Practicability: It is not clear that the NRA should be particularly concerned about how a database provider chose to charge for its services (per request, annual subscription fee, etc.) as this would be part of the business model it chose to deploy, unless there was a likelihood of anti-competitive charging behaviour arising. However, if there did not seem to be a practical way of charging for its service, database providers may choose not to enter the market. Therefore the NRA may need to engage with industry to determine whether this was likely to be a concern.

6.4.5.2 Conclusion

The above analysis suggests the NRA should consider allowing database providers to charge WSD users for access to their databases. Competition between database providers would ensure their costs are efficiently incurred (although they would also likely pass on costs from further upstream which may not be i.e. costs from the NRA and incumbents) and should ensure minimal distortion of competition in the downstream market for WSD users.

6.5 WSDBS REGULATION AND REQUIREMENTS

Database assisted operation is a new approach to managing spectrum and as a result there is no experience or a clearly defined framework for regulating databases. When considering how to put this in place, a NRA is likely to consider the following questions:

- 1 How to ensure that only databases approved by the NRA provide service to devices;
- 2 What is the legal instrument that enables WSDB operation;
- 3 What are the obligations of a WSDB.

These issues are considered below.

6.5.1 Avoiding non authorised WSDBs

A key requirement from an NRA perspective is that WS devices get their operating parameters from a database that has calculated them according to the rules laid out by the NRA. It may be difficult for the NRA to stop "rogue" database providers. This is because a database can be easily set up and made available in the internet, and it would be difficult for a NRA to police and enforce that this does not happen. In practice, this requirement is addressed more easily at the device level: the NRA may include in the relevant device regulations an obligation on devices to contact only the approved databases, and possibly list those databases in the regulations. This approach puts the burden on users and on device manufacturers. This is also the approach followed in the ETSI Harmonised Standard EN 301 598 [2], which includes explicit requirements that a) devices must get the list of approved databases from the NRA, and b) device can only transmit according to parameters provided by a database that is in the list.

6.5.2 Legal framework for WSDBs

WSDB providers will normally not operate transmitting equipment – as noted above a WSDB is a system that responds to queries over the internet – so the usual spectrum authorisation regime is not directly applicable to them. NRA may be able to put in place a certification regime and to regulate WSDBs directly, but the precise form of this will depend on the NRA powers and the legal framework in each jurisdiction. As a result the legal instrument that lays out the relationship between the NRA and the WSDBs will vary. For instance:

- In the UK, Ofcom operates under a framework that does not give it explicit powers to licence or authorise a WSDB. As result, Ofcom is managing its relationship with WSDB providers through a contract. This contract lays out in detail the obligations of the WSDBs and the incumbent data that WSDBs will get from Ofcom. Ofcom conducts a through qualification process with each candidates WSDB, at the end of which the provider becomes a qualifying WSDB and gets listed in the regulations and on a web list hosted by Ofcom;
- In the US, the FCC spelt out the criteria for a WSDB provider in the rules and then ran a process where providers could apply to be considered. In this application process the provider had to describe it's capabilities, plans and proposals for how it would develop and run a WSDB. The FCC chose 'viable' candidates and then the WSDB candidate had to go through a certification process. Once the FCC was satisfied that the WSDB and the WSDB operator were acceptable they published a notice (a letter in effect) that authorised the WSDB operator to provide service. There is no contract as in the UK, though some of the elements that are present in the Ofcom contract are described in the FCC rules, the application process, or were validated by the FCC during certification.

6.5.3 WSDB obligations

Independently of the legal instrument, it is likely that the NRA will want to ensure that WSDB behave in a certain way, and that they comply with certain requirements. Most notably, the NRA will want to be sure that a database performs the calculation process correctly as errors could lead to interference to incumbents. Other things that the NRA may want to capture are:

6.5.3.1 *Compliance with the NRA requirements*

There is likely to be some sort of certification process, whereby the candidate provider will show that it is capable of performing according to the NRA specification. This certification could include:

- a verification of the calculations. This could cover the correct implementation of the algorithms, and also the ability to incorporate incumbent data timely into the calculations. in particular when it is of dynamic nature;
- a self-declaration of how the provider complies with other requirements not easily observable;
- examination of the interactions of a real or a virtual device and the database under test.

6.5.3.2 Support to the NRA on interference management

NRAs are likely to be particularly cautious when it comes to interference from TVWS because of WS devices using the same frequencies as existing users and because the database assisted operation is a new approach. As a result, the NRA may require specific interference management functions from the database. In the case of the UK for instance, WSDB providers are required to offer to Ofcom:

- A WS information system, where Ofcom can see the locations and channels used by WS devices at any point in time;
- A function to turn down any WS device within a short period of time at the command of Ofcom;
- The ability to contact a person at the WSDB provider in case an emergency occurs.

6.5.3.3 Responsibilities in case of interference

The NRA may want to put part of responsibility for interference on the WSDB and have penalties in case it occurs. However there is likely to be pushback from the WSDB providers, as interference may occur for reasons that are beyond the control of the WSDB. For instance, a user could misconfigure the device, or the incumbent data could be wrong. Therefore it seems reasonable to limit the responsibilities of the WSDB to the parts of the framework that it performs, most notably the calculations.

6.5.3.4 Security

The NRA may want to include conditions about how the data is exchanged between the database and the devices, and about how the data is handled internally. The exchange of parameters with devices is a particular concern, as tampering with this data in transit could result in interference to incumbents.

6.5.3.5 Data capture and reporting

Database operation gives the NRA access to usage information in a way that is not available for existing licence exempt bands. Since all devices must get their parameters from a database, these can capture a wealth of data about the types of devices and the characteristics of the use.

The NRA may want to include requirements for WSDB to collect and report usage data, which the NRA can then use for policy making and spectrum management.

7 HOW TO PREVENT INTERFERENCE?

7.1 INTERFERENCE TO INCUMBENTS

A major issue for administrations considering the implementation of a national regulatory framework for TV WSD using geo-location databases is how to turn the conclusions of ECC technical deliverables (see section 4.1) into specific technical requirements for WSDB solutions.

The main responsibility of a NRA when implementing TVWS regulations is to ensure that incumbent users are protected. This is achieved by a set of rules that specify how the WSD availability is calculated by the WSDB.

This section follows from section 6.1 on what specific functions should the WSDB perform with the aim of providing a reference overall methodology and possible common terminologies for defining technical rules to be implemented on the so called “calculation engine” of WSDB solutions. This reference methodology is based on the technical rules that Ofcom has implemented for the UK pilot, in which the regulator itself carried some of the translation processes, and provide a dataset of results to the databases – in the form of powers and channels available for WS usage at all points in grid covering the country. This was in particular the case for the DTT translation process. The DTT co-existence framework for calculating WSD powers in the UK is based on a pre-agreed interference limits and requires complex calculations using data which is sensitive to the incumbent DTT broadcasters.

As DTT networks do not change frequently, a NRA that follows the UK models would have to repeat the calculations and deliver updated data files to WSDB providers only a few times in a year.

As opposed to DTT, information on PMSE frequency assignment – if available – may have to be updated quite frequently as PMSE use is dynamic in nature.

As underlined above, the overall methodology described in this report reflects the choices made by one administration at the time when the report was published. It is likely that various enhancements could be envisaged. National administration wishing to implement geo-located TVWS regulations should take due consideration of national situation and identify necessary adjustments.

A high level description of the rules that Ofcom has implemented for the UK pilot for calculation of operational parameters is provided in ANNEX 2.

Ofcom UK published in February 2015 a statement with the policy decisions on implementing TV white spaces. The statement includes conclusions on all aspects of the framework including coexistence and can be found here: <http://stakeholders.ofcom.org.uk/consultations/white-space-coexistence/statement>

7.1.1 Calculation of the WSD e.i.r.p. levels to ensure protection of incumbents

The figure below illustrates the various emission limits, and the entities responsible for their calculations, which need to be computed under the technical rules set in the UK:

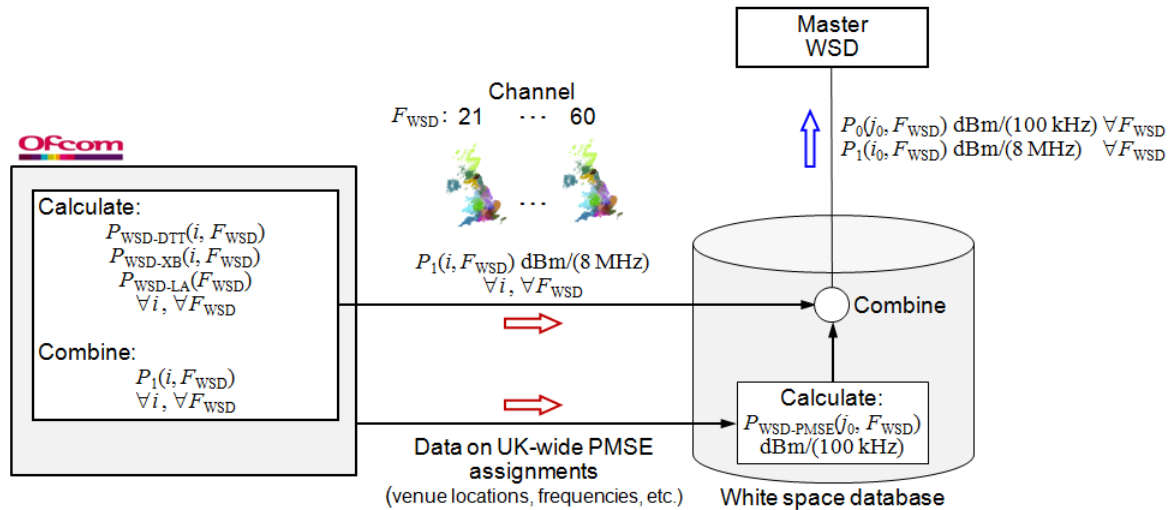

Figure 3: Spatial resolution: 100 metre x 100 metre geographic pixels (“pixels”)

The terms location and pixel are used interchangeably. A 100 m spatial resolution is used in the UK Planning Model (UK PM). For illustration, the area of the UK is covered by over 20 million pixels.

Frequency resolution:

- DTT: 8 MHz channels (21... 60);
- PMSE: 100 kHz channels.

WSD location and frequency index:

- i_{WSD} WSD transmitter location/pixel index;
- F_{WSD} WSD channel index, 21 to 60.

The methodologies for setting the protection calculations would be somewhat different for each of these incumbents:

- Protection of national DTT;
- Protection of cross border DTT, or other cross border incumbent usage;
- Protection of other usage, based on location agnostic limits;
- Protection of coordinated PMSE.

Limits:

$P_{WSD-DTT}(i, F_{WSD})$	e.i.r.p. limit in dBm/(8 MHz) for WSD to operate DTT channel F_{WSD} in geographic pixel i to protect DTT
$P_{WSD-XB}(i, F_{WSD})$	e.i.r.p. limit in dBm/(8 MHz) for WSD to operate DTT channel F_{WSD} in geographic pixel i to protect operate DTT channel F_{WSD} in neighbouring countries, or other incumbent usage, subject to relevant coordination trigger threshold
$P_{WSD-LA}(F_{WSD})$	e.i.r.p. limit in dBm/(8 MHz) specified by the NRA as location-agnostic limits in each channel $F_{WSD} = 21...60$.
$P_1(i, F_{WSD})$	The minimum of limits $P_{WSD-DTT}(i, F_{WSD})$, $P_{WSD-XB}(i, F_{WSD})$, and $P_{WSD-LA}(F_{WSD})$ limits in dBm/(8 MHz).
$P_{WSD-PMSE}(j, F_{WSD})$	e.i.r.p. limit in dBm/(100 kHz) for WSD to operate DTT channel F_{WSD} in geographic pixel j to protect PMSE equipment

7.1.1.1 Protection of DTT

The DTT network can be described using the following notation:

- i_{DTT} DTT receiver location/pixel index;
- F_{DTT} DTT channel index, 21 to 60;
- l_{DTT} DTT transmitter index.

At each DTT receiver pixel i_{DTT} , the NRA specifies a list of all serving DTT transmitters $\{l_{DTT}\}$ and protected DTT channels $\{F_{DTT}\}$.

Protected DTT channels $\{F_{DTT}\}$ refers to the channels served that should be taken into account in the computation of the $P_{WSD-DTT}(i, F_{WSD})$ limit. DTT channels in an unpopulated DTT pixel or which are not meeting certain criteria in a DTT pixel would be considered as “non protected” and therefore disregarded in the calculations.

WSD regulatory emission limit ($P_{WSD-DTT}$) to protect DTT

The WSD regulatory emission limit $P_{WSD-DTT}$ at location i_{WSD} and in channel F_{WSD} is given by:

$$P_{WSD-DTT}(i_{WSD}, F_{WSD}) = \min_{i_{DTT}, l_{DTT}, F_{DTT}} \left\{ P_{WSD}(i_{WSD}, F_{WSD}, i_{DTT}, l_{DTT}, F_{DTT}) \right\}$$

The WSD e.i.r.p. $P_{WSD}(F_{WSD}, F_{DTT}, i_{WSD}, i_{DTT}, l_{DTT})$ should be defined by the NRA as the function to ensure a desired protection criteria in DTT receiver pixel i_{DTT} , for protected DTT channel F_{DTT} served by DTT transmitters l_{DTT} .

It is defined in the UK model as a function of the coupling gain G , protection ratio r , and maximum permitted nuisance power Z (see ANNEX 2). It accounts among others for path loss, antenna discrimination, adjacent channel leakage ratio (ACLR) of the WSD and the adjacent channel selectivity (ACS) of the receiver.

Furthermore, for a given WSD location i_{WSD} , it is not necessary to calculate $P_{WSD}(F_{WSD}, F_{DTT}, i_{WSD}, i_{DTT}, l_{DTT})$ for all national DTT pixels, since a DTT pixel that is a large distance away would not affect the WSD regulatory limits, and as such is not relevant. For each WSD location i_{WSD} , a list of relevant DTT pixel locations $\{i_{DTT}\}$ can be calculated. Such DTT pixels will be defined as those that are a distance R_{REL} or less from the WSD location i_{WSD} , where distance is measured between the pixel centres. Ofcom is using a value of R_{REL} of 20 km for co-channel, and 2 km for adjacent channel calculations.

Finally, a WSD is not allowed to operate co-channel with a DTT channel that is protected at the DTT receiver pixel. In other words, $P_{WSD}(F_{WSD}, F_{DTT}, i_{WSD}, i_{DTT}, l_{DTT}) = 0$ if $F_{WSD} = F_{DTT}$.

In sum, the WSD regulatory emission limit $P_{WSD-DTT}$ at location i_{WSD} and in channel F_{WSD} will be derived by performing minimisation of P_{WSD} :

- For each protected location i_{DTT} (relevant to i_{WSD});
- For each protected DTT transmitter l_{DTT} (relevant to i_{WSD});
- For each protected DTT channel F_{DTT} (relevant to l_{DTT}).

The WSD regulatory emission limit $P_{WSD-DTT}$ will be calculated at all location i_{WSD} and for all channels F_{WSD} .

The output of this algorithm is a set of TVWS availability maps for protection of DTT. Ofcom generates a map for each combination of WSD emission class (5 in the current ETSI standard) and of a set of device heights. Each map provides the maximum e.i.r.p. that a WSD can use in each DTT channel and at each 100 meters x 100 metres pixel in the UK.

7.1.1.2 Emission limits for protection of cross border

In the relation to cross border DTT, or other cross border usage, the derivation of location-specific TVWS availability can be formulated as the following problem:

Calculate the maximum permitted WSD in-block e.i.r.p., $P_{WSD-XB}(i, F_{WSD})$, for a WSD located in a geographic pixel indexed as i , and radiating in channel F_{WSD} , subject to the received field strength in neighbouring countries not exceeding relevant international coordination trigger threshold in channel F_{WSD} .

The NRA would be responsible for generating TVWS availability datasets in relation to cross border DTT.

7.1.1.3 Calculation of location agnostic limits

Under this reference methodology, the WSD emission limits are simply specified by the NRA as location-agnostic limits, $P_{LA}(F_{WSD})$, in each channel $F_{WSD} = 21 \dots 60$.

Location-agnostic WSD emission limits would be applied in the UK in the context of seeking to ensure a low probability of harmful interference to uses above and below the UHF TV band, as well as PMSE usage in channel 38.

7.1.1.4 Combining of emission limits (P1)

The combination of the above limits measured in 8 MHz DTT channels consists of performing minimisation of $P_{WSD-DTT}(i, F_{WSD})$, $P_{WSD-XB}(i, F_{WSD})$, and $P_{WSD-LA}(F_{WSD})$. Cross border restrictions and location agnostic limit are in this approach applied as an overlay on the restrictions relating to national DTT.

The NRA could generate a unique TVWS availability dataset that provides $P_1(i, F_{WSD})$ limits.

P_1 is the Maximum in-block RF e.i.r.p. for a DTT channel, defined in the ETSI standard as one of the operational parameters that a WSDB provides to a WSD.

7.1.1.5 Emission limits for protection of PMSE

Specifically, the derivation of location-specific TVWS availability can be formulated as the following problem:

Calculate the maximum permitted WSD in-block e.i.r.p., $P_{WSD-PMSE}(j, F_{WSD})$, for a WSD located in a geographic location indexed as j , and radiating in channel F_{WSD} , subject to a given PMSE wanted-to-unwanted power ratio in any channel $F_{DTT} = 21$ to 60.

The limit $P_{WSD-PMSE}(j, F_{WSD})$ is measured over 100 kHz, since the vast majority of PMSE equipment operate in bandwidths of 200 kHz or less, and so a finer resolution than 8 MHz is required.

WSDBs would be responsible for performing the above calculations under this UK model. It implies that the NRA can provide the WSDB with a list of PMSE assignments including detailed characteristics of each assignment, such as location and equipment type.

The specific algorithm implemented in the UK is provided in Annex 2.

7.1.2 Calculation of operational parameters

Annex 2 presents an overview of how a WSDB operating in the UK would calculate specific operational parameters defined in ETSI EN 301 598 [2], including how location uncertainty is calculated.

7.2 INTERFERENCE FROM ONE WS DEVICE TO ANOTHER WS DEVICE AND DEALING WITH CONGESTION

The situation where two (or more) devices wish to access the radio resources at the same time and location may result in interference and ultimately congestion. The problem is of course not unique to access to white spaces, and it has been resolved in various ways in other spectrum bands. In some cases, for instance when the density of use is very low, the best solution may be to do nothing as the likelihood of interference will be low. In other cases the solution may be a centralised system that allocates resources so as to avoid interference and manage congestion, such as the Radio Resource Management function of mobile networks.

The NRA has therefore alternatives to deal with interference in TV WS. The choice of the most adequate is not straightforward and there is a risk of making the wrong regulatory choices in the absence of a clear understanding of what the interference scenario might look like. A key element for this is the knowledge of the types of applications and technologies that would be used in the band, and their characteristics in particular with regards to spectrum access profile (for instance short data bursts vs. continuous transmissions) and desired quality of service.

With regards to applications, the evidence from the US and from the UK pilot show interest from a raster of applications that have very different spectrum access profiles. For instance, machine-to-machine communications have very low data rates and occasional transmissions, whereas pico-broadcast occupy a DTT channel continuously but are unidirectional. The ideal contention and interference management techniques would be very different for each. However, at this stage of development of WS use it is very difficult to determine what type of applications will take hold.

Furthermore, the technologies that are deployed in WS could, without regulatory intervention, incorporate mechanisms to deal with contention such as polite protocols. IEEE 802.11af [13] for instance, shares the MAC layer with other 802.11 versions and incorporates CSMA/CA.

In the light of the uncertainty about the applications and technologies that would be causing and suffering the interference, it seems wise to adopt an initial watching brief from a regulatory perspective. This would allow NRAs to gain a better understanding of the applications and technologies that take hold in the band, and would also give the opportunity to the industry and standardisation organisations to develop their own solutions – before taking regulatory action. An initial regulatory do-nothing approach would be facilitated by the fact that the number of devices in the field is likely to remain low in the short term and hence interference would be unlikely to appear.

7.2.1 Options for dealing with interference and congestion

Following clear evidence of interference becoming a problem and a clearer picture of what the band is being used for, the NRA could consider taking action in broadly two forms.

- A first option could be to change the rules that WSDBs follow when providing parameters to devices.
- A second option could be that WSDBs, or a separate entity, coordinate the access to spectrum - in a way similar to the Radio Resources Management function of a mobile network. There are two sub-options for this approach: the NRA could allow WSDBs, acting on a voluntary i.e. not regulated basis to coordinate device access to the spectrum. Alternatively, the NRA could consider mandating WSDBs to share the information about WS use and to coordinate access.

These options are considered in more detail below:

7.2.1.1 *Device-based approach*

As a first option, it could be possible to rely on devices to deal with interference and congestion. This would be similar to the approach in other licence exempt bands. Devices that are polite, for instance by having a low duty cycle, low power or listen before transmit mechanisms could be given priority of access. For this, new device classes with associated politeness requirements could be introduced in the ETSI standard or the regulations. The regulator would then instruct the databases to change the calculation rules so that the new classes have priority. Congestion would be dealt with at two levels: impolite, older devices would be given lower priority, and polite devices would deal contention for the resources in a way similar to existing licence exempt bands.

In practice, this option would mean additional requirements mandated through the Harmonised Standard in the future. Certain device characteristics would be required to solve the interference issue between the WSDs or allow dealing with congestion.

Database assisted operation allows the regulator to easily and quickly change the rules to allow this. This is unlikely traditional licence exemption, where device that are already on the field cannot be instructed to yield to newer, more polite devices.

7.2.1.2 WSDB coordination

A second option is to rely on the WSDB service to deal with interference and congestion. The regulator could instruct databases to assign radio resources to WS devices in a way that mitigates interference among them. Devices would then access the resources in a coordinated manner, similar to a network. To a certain extent this approach could be put in place voluntarily by databases without NRA intervention as databases already have information about other devices (they have authorised) in the field. A database could calculate availability according to the rules specified by the NRA and then assign the resources to devices in a way that minimises interference. However, to be truly effective in a multiple database environment, all databases will need to share device information. This is something that some database operators may not voluntarily agree to do, and hence that the regulator would have to enforce.

In the context of coordinated use, there will be congestion when the demand for access is such that coordination cannot ensure interference free operation. The regulator will have to define rules that specify how resources are assigned after coordination techniques are exhausted and do not guarantee interference free operation for all. One such rule could be the introduction of a high priority tier, priority access. Use of the priority access could ensure that the applications that require access to sufficient spectrum resources can rely on the availability of spectrum. This could be combined to avoidance of harmful interference between the WSD's, allowing those applications to provide required QoS.

There are two important issues to be considered when making a regulatory requirement for database coordination:

- Competition. Coordination requires that databases exchange information about the WS devices with other databases. This should be done in anonymous manner as sharing customer information with competitors and could be considered a breach of competition law;
- Data privacy. The information that databases would need to exchange could be considered personal data in some jurisdictions. In particular this could be the case of the device location. Depending on the data protection regime, it may not be possible for databases to pass on that information to external organisations.

There are some technologies already that implement various forms of coordination functions. One such technology is being standardised at ETSI and is described below.

7.2.2 Coordination technologies

ETSI is working on the standardisation of coordinated use of TV WS, which ensures protection of CRS's from harmful interference from other CRS's, and facilitates mitigation of the aggregate interference from CRS's to the incumbents and other CRS's, which are both issues in the scope of article 3.2 of the Directive 1999/5/EC. The mechanisms defined as part of the coordinated use allow also access to defined spectrum resources with required certainty.

The ETSI defined TVWS System architecture that includes the use of both the coordinated and uncoordinated use of TVWS is captured in the figure below.

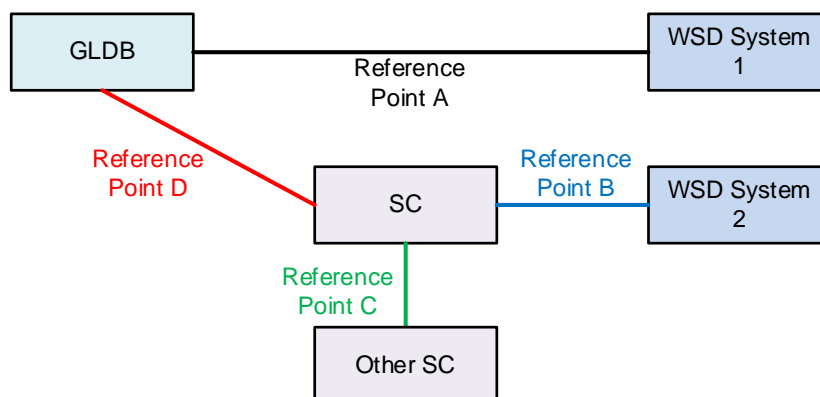

Figure 4: Overview of TV white spaces system TS 103 145 [7]

In the above figure, the WSD system represents a white spaces device (WSD) or network of WSDs (i.e. a master WSD and some slave WSDs). The WSD System uses available white space resources obtained with the help of geo-location database (GLDB) and/or the WSD System uses available white space resources obtained with the help of GLDB and with additional knowledge of spectrum usage by its neighbour WSD Systems provided by the spectrum coordinator (SC). In particular, the latter represents the coordinated usage of TVWS, which is covered through communication over reference points B, C, and D, which are being standardised by ETSI RRS.

The SC is responsible for coordinating spectrum usage of WSD Systems based on the information obtained from the GLDB, as well as supplemental spectrum usage data from different WSD Systems using its service. It is also responsible for managing the radio resources among a set of WSD Systems that are potentially interfering with each other and, allowing for channel assignment to a WSD System that wishes to operate exclusively on a channel and with priority over other WSD Systems (priority-based channel assignment). The priority-based channel assignment is managed by the SC based on some minimum protection requirements requested by the WSD System, which includes minimum bandwidth, minimum SINR (or maximum allowable interference), and some guaranteed minimum availability time. The SC translates these requirements into protection criteria, which are used by the GLDB to ensure that the priority-based channel assignment is maintained in the presence of other WSDs not using the services of the SC.

In a typical resource assignment process for coordinated usage, the master WSD sends device parameters to a GLDB via the SC. The SC acts as relay and can also store the device parameters of the master WSD. The SC, during the process, collects and maintains additional data about spectrum usage of the different WSD Systems using its service. This additional data contains information that reflects the current state of spectrum usage, possibly including spectrum measurement data from WSDs, and usage maps or areas of occupancy of the different WSD Systems. It also contains parameters specific to the Radio Access Technology of each WSD that facilitates coexistence. From the device parameters of the WSD, the GLDB determines specific operational parameters for the WSD that protect the incumbent. SC then determines the operational parameters using the information obtained from the GLDB as well as the additional data about spectrum usage of the different WSD Systems, and sends these refined operational parameters to the master WSD in response to the request for white space access. The operational parameters determined by the SC shall not violate the protection criteria of the incumbent, and are therefore compliant with the information obtained from the GLDB. The master WSD then sends the selected channel usage parameter to the GLDB via the SC. The SC will also update its additional spectrum usage data based on information sent by the WSD. At any time in the process of assigning channels to the WSD Systems, the SC could reconfigure the channel usage of the WSD Systems to ensure an efficient use of spectrum, such as for reducing fragmentation in the available spectrum.

The functionality implemented in the SC to allow coordinated usage of TVWS comprises of the following:

- **Coexistence functionality:** This functionality serves as the main engine in the spectrum coordination function. It uses the best-case operational parameters obtained from the GLDB (available channels and maximum power) and modifies these parameters to further allow different WSD Systems connected to the SC to operate (either on the same channel or adjacent channels) without harmful interference to each other. The coexistence functionality will collect the device parameters as well as additional RAT-specific information that is needed for coexistence from the WSD. Based on the current usage of the channels by the different WSDs, the coexistence function can request additional information to be obtained from the sensing function in order to make coexistence decisions;
- **Sensing and measurement functionality:** The sensing and measurement functionality configures appropriate sensing in the WSDs in order to detect the presence of other WSDs or incumbents which may cause coexistence issues for the WSDs themselves. The sensing results and the specific measurements performed by the WSDs according to its RAT are collected by the sensing functionality and used by the coexistence functionality to further define the allowable channels and operational parameters for WSD Systems to ensure coexistence. Such sensing results and measurements are used by the SC for determining the presence of other WSD Systems (which may or may not be using the services of the SC) or interference from nearby incumbent services in the operating or adjacent channel which may affect the WSD Systems. Information from the sensing and measurement functionality can be used by the coexistence functionality to define the operational parameters of the WSD Systems or provide further information to the WSD Systems to ensure coexistence;
- **Priority-Based Channel Assignment and negotiation functionality:** This functionality will allow the WSD Systems to reserve channels for priority access and provides all functionality related to negotiation between different WSD Systems that may request priority access for periods of time. It also collects and manages the requests for priority-based channel assignment from the WSD Systems, including authentication of users which are allowed to apply for priority-based channel assignment as well as negotiation for channel assignment. Such negotiation could include auctions managed by the SC, cost set through administration, or priority-based channel assignment to specific WSD Systems which are allowed to do so based on regulator policies.

Congestion as such is not covered by ETSI, but the priority use of TVWS facilitated by the coordinated use can ensure that services that require provisioning of QoS can be delivered even in the case the spectrum demand would otherwise block the channels.

8 OTHER TASKS OF THE NRA

8.1 ESTIMATION OF WHITE SPACE AVAILABILITY

Among critical tasks for NRAs, there should be the need to provide some visibility on “WS availability” in a useful way.

8.1.1 General UHF spectrum availability for WSD

WSD spectrum usage in the UHF band will be constrained by the requirement to protect incumbent primary users; There is a clear long-term risk to WSD services, that access to spectrum will change dependent upon overall changes to the long term use of the UHF spectrum, changes to the DTT network, PMSE deployments, changes to the co-existence framework for interference mitigation and the potential for other WSD users. However the WSD geo-location database approach allows regulators the capability to model WSD spectrum availability for a range of WSD technologies and deployment options. WSD spectrum availability is an important parameter for potential new TVWS service providers. TVWS service providers in this context might be geo-location database providers, network operators or technology vendors. The choice of WSD parameters directly affects WSD spectrum availability due to the requirement to protect the incumbent services. Examples of varying WSD parameters could include antenna height, RF coupling gain, or protection ratio class. In the UK, the regulator selects a range of the most likely WSD operating parameters, and uses this data to calculate then publish a range of WSD spectrum options. This is useful for potential WSD operators to determine if sufficient UHF spectrum is available for a particular type of application. For example rural broadband services might require high power radio links in remote rural areas, but other technologies might operate at significantly lower power levels in urban or sub-urban locations for local home networking or machine-to-machine applications. Without knowing the potential spectrum availability for a particular WSD technology, it is very difficult to establish if a particular application can be provided with sufficient UHF spectrum over a given geographical area, region or even country.

8.1.2 Longer Term WSD spectrum availability

It is important for regulators to evaluate and publish the potential long term spectrum availability for WSD. This is not a trivial task and requires both flexibility in modelling tools, which allow for the potential future changes in the use of the UHF spectrum, and the willingness to remodel WSD spectrum availability after events such as WRC-15. The UHF band is subject to future discussion at WRC-15 in terms of co-primary access of IMT services with DTT services in the 700MHz band and the potential deployment of PPDR. All of these factors will introduce new sharing studies and will have an impact on WSD spectrum availability. Modelling the potential WSD spectrum availability for a range of these outcomes by the regulator is essential in determining the WSD spectrum availability.

8.1.3 PMSE Usage

PMSE usage may also change the spectrum availability for WSD in certain geographical locations. Identifying normal PMSE usage patterns and building this into the WSD spectrum availability would also benefit potential WSD providers.

8.1.4 Undertaking the Calculations and publishing the spectrum availability data

It is useful for potential users of TVWS to understand the spectrum availability that they can expect if they were to deploy devices. For example, a potential service may require several channels at high power, which may not be available at the location where the service is to be deployed. A database may make availability information public, but this will not happen until a database has been approved. However, potential users may want to have a view of the overall availability in the country. The regulator is best positioned to provide this, as it most likely will lead on the definition of the rules for calculation and have visibility of the incumbent usage.

Calculating WSD spectrum availability is not trivial and can be computationally extensive, in particular if it is to generate results for a whole country. Also, the information has to be presented in a meaningful way - for instance a large data table is unlikely to be useful for an end user. Instead, summary charts and maps should be preferred. There can be a large number of parameter combinations (device height, allowed e.i.r.p., emissions class). A set of scenarios that present combinations of parameters that are likely in real life could be a useful way to filter the data. It may be useful to present results for selected locations, such as major cities or locations that have particularly good or bad availability, in addition to country-wide charts.

Finally, it is likely that the regulator does not get the rules right from the beginning of the policy making process. It would normally change and refine the rules as a result of stakeholder input or of measurement campaigns. This means that the availability results will normally change, perhaps substantially, during the process and the regulator will need to run the calculations several times.

The following figures, taken from past publications from Ofcom in the UK, provide an example of how TVWS availability can be presented (note that these charts do not accurately represent current TVWS availability in the UK).

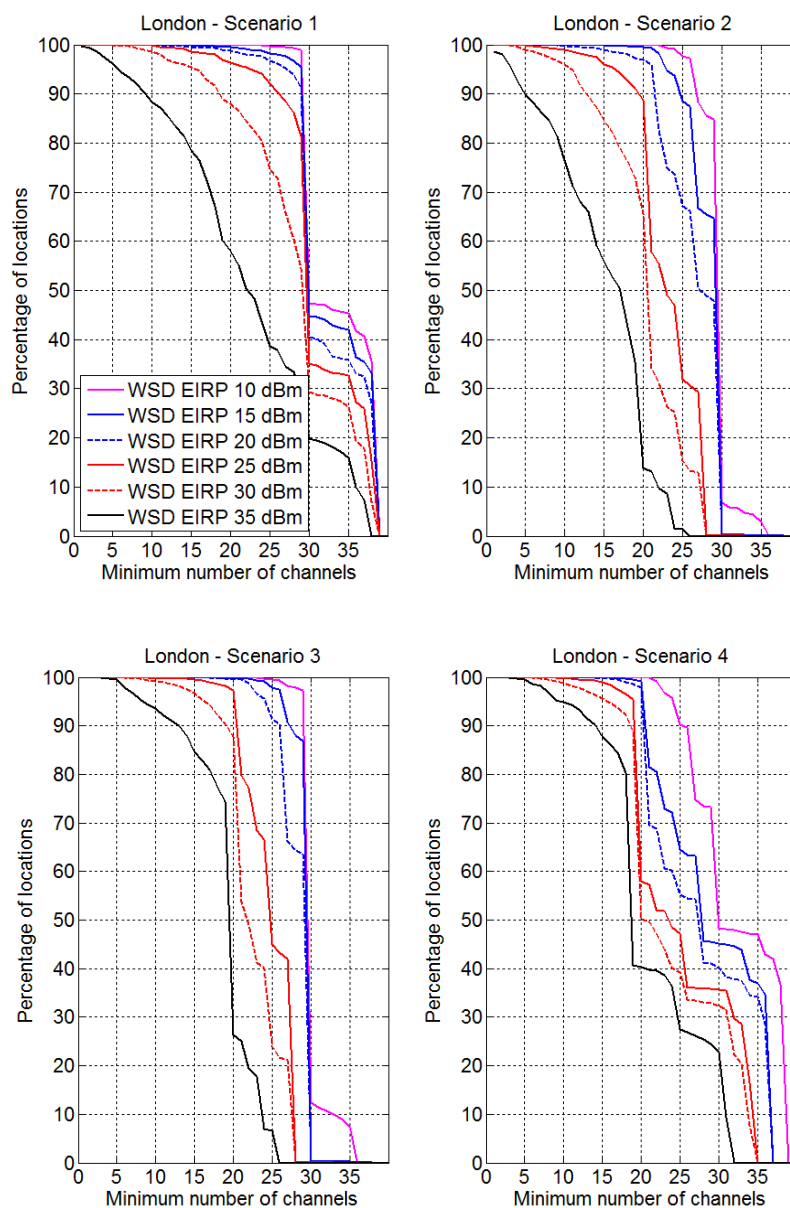

Figure 5: Examples of TVWS availability charts (NOT accurate results)

Figure 5 above represents the percentage of locations in the London area where a number of TVWS channels can be used, for 4 scenarios and different WS device powers. The charts take account of protection of DTT and of PMSE. The scenarios correspond to a geo-located device, with different combinations of antenna height and emissions class as follows: Scenario 1: antenna height 15 metres, emission class 1. Scenario 2: antenna height 10 metres, emission class 4. Scenario 3: antenna height 1.5 metres, emission class 4. Scenario 4: antenna height 1.5 metres, emission class 5. Geo-located device in all scenarios

For instance, the first chart (scenario 1) shows that a WSD operating at 35 dBm will be provided approximately 15 channels at 80% of locations in London.

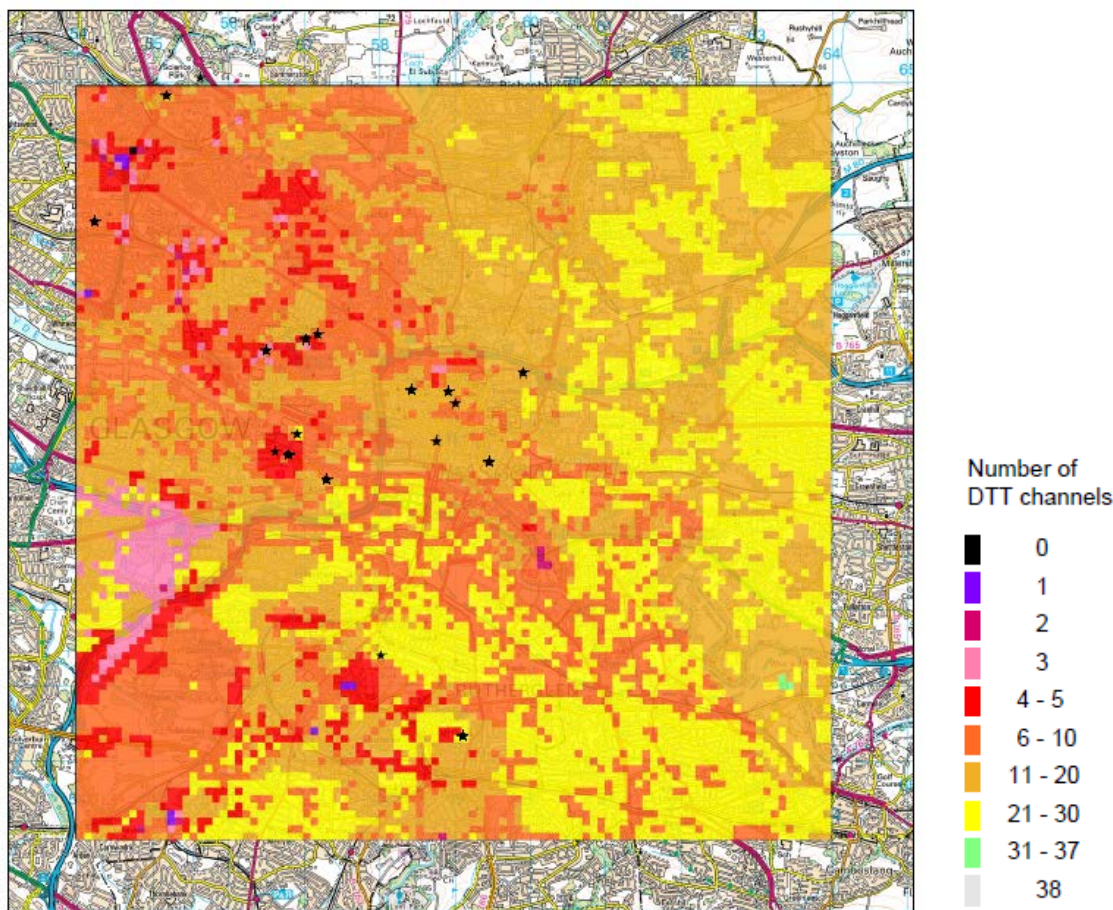

Figure 6: Example of TVWS availability map (NOT accurate results)

8.2 GATHERING INCUMBENT INFORMATION

In some jurisdictions the NRA may have detailed information of the incumbent use – this is for instance the case of the UK where PMSE usage is individually authorised and very detailed data about the DTT location probability is available. Other NRAs may not have such level of detail if, for instance, PMSE use is under a general authorisation regime. In such scenarios the NRA may need to put in place the mechanisms to capture incumbent use prior to allowing WS use.

8.3 QUALIFYING WSDBS AND MAINTAINING THE LIST OF QUALIFIED WSDBS

If WS resources are not correctly assigned to devices there is a significant risk of interference to incumbents. The WSDBs will play the key role of in this function, therefore it is paramount that they perform the function to a high standard. Prior to allowing a WSDB to operate the NRA will have to conduct an assessment of the ability of the operator to perform the task. Once a WSDB operator has passed the qualification, the NRA will

add it to the list of WSDBs authorised to operate in the regulatory domain. The NRA will have to maintain that list and make it accessible to devices via the internet.

8.4 ENFORCEMENT AND INTERFERENCE MANAGEMENT

Overview of the processes and functions required to deal with interference events, in particular through interaction with the WSDBs and taking advantage of the device functionality required by the ETSI EN.

8.5 IMPLEMENTATION CONSIDERATIONS: STAGED INTRODUCTION

Given the novelty of the database approach and the co-existence with services in the same band, a NRA may decide to start implementation with trials limited geographically or in terms of authorised RF power.

8.6 ONGOING REVIEW

There are several reasons why a NRA is likely to have an ongoing involvement in support of access to TVWS.

- It can be difficult to get the coexistence rules right with the first iteration. The rules involve a balance between maintaining the risk of interference to incumbents low, and allowing access to TVWS to a level that is sufficient to develop services. If coexistence is based on extreme worst scenarios of interference, it is likely that very little TVWS will be left. It is difficult to get this balance absolutely right on the basis of assumptions about TVWS deployments, hence it seems prudent to start with a relatively conservative approach to interference, and then re-evaluate and potentially relax if appears that actual TVWS use does not cause interference;
- It is unclear what services and applications will take hold. New applications may be developed, and require changes to the rules in some form to make them viable;
- Congestion may appear if TVWS use becomes successful, in which case the NRA may want to intervene if it appears that industry alone is not able of addressing the problem.

8.7 CROSS BORDER ISSUES

At each border of a country where WSDBs are operated, harmful interference from WSD(s) may occur to incumbents across the boundary. In principle the NRA is responsible to provide the necessary information to the WSDBs operated in its country about the constraints resulting from the coordination negotiations with neighbouring countries. These negotiations may overrule the baseline from GE06. However, even in this more tailored case this could result in rather static protection criteria based on worst case scenarios on both sides of the border. To avoid this, NRAs could consider imposing an interface between WSDBs on database operators. Each WSDB can communicate and exchange the information on its incumbent systems with adjacent WSDB(s), when available, through the interface. The WSDB can then protect the incumbent(s) in adjacent areas by using this information. ETSI is developing Technical Specifications and European Standards for this information exchange, see section 4.2.

9 CONCLUSIONS

This report aims to provide a comprehensive review of various issues to be considered by administrations wishing to implement TVWS regulations. Guidance is given in order to support proper assessment on costs and benefits, and on practical feasibility of national implementation.

It may be worth to mention the fact that different circumstances can lead to different implementations and even different regulatory approaches.

Depending on national legislation, which could exclude for specific reasons the possibility of sharing with DTT in the UHF Band, TV White spaces may not be possible to be implemented at all in the UHF band.

Finally, from a European implementation perspective, it should be noted that ETSI EN 301 598 [2] contains the concept of the web-listing, which is the list of White Space Databases authorised by a NRA to operate in the geographical domain under the NRA's jurisdiction, and that the EN includes requirements for White Space Master Devices to 1) obtain the web-listing and then 2) only contact a WSDB that appears in that web-listing.

In order to allow a timely update of regulatory information on national implementation status and provision of links to national web-listing when available, it is envisaged that ECC could manage through ECO a list of national web-listings within CEPT. The assumption is that each NRA which intends to implement TVWS regulations will create or make available a single web-listing which will contain web-links to the approved WSDBs for their territories. The national single web-listing would be a device-readable list of WSDBs certified by the NRA whereas a general repository managed by the ECO would basically be a human readable web page.

ANNEX 1: ETSI EN 301 598

EN 301 598 [2] is based on a model for access to TVWSs which involves four entities:

- White space databases WSDB – WSDBs provide devices the parameters for the radio transmissions, so that devices do not cause undue interference to the primary users;
- WSDB regulatory listing – this identifies the WSDBs that are authorised by a national regulatory authority (NRA) to provide service in the relevant jurisdiction;
- Master WSDs – geo-located devices capable of communicating with a WSDB and of accessing the regulatory list;
- Slave WSDs – devices that do not communicate directly with a WSDB, but instead operate under the control of a master WSD.

WSDBs and master devices exchange information to determine the parameters of the radio transmissions, EN 301 598 specifies three datasets for this:

- Device parameters are the parameters that WSDs will communicate to a WSDB in order to provide the WSDB with relevant information about the device. These parameters include the technical characteristics of the device and its location;
- Operational Parameters are generated by a WSDB and communicated to WSDs. They specify the radio resources (frequencies and powers) and other instructions which WSDs must comply with. There are two types of operational parameters;
 - Specific operational parameters; the WSDB derives these for a particular WSD, on the basis of the WSD’s specific device parameters;
 - Generic operational parameters; these parameters could be used by any slave WSD located in the coverage area of a master WSD;
- Channel Usage Parameters; these are reported back by a WSD to a WSDB to inform of the actual radio resources that it will use.

A typical sequence of events in the interactions between the four entities above is shown in Figure 7:

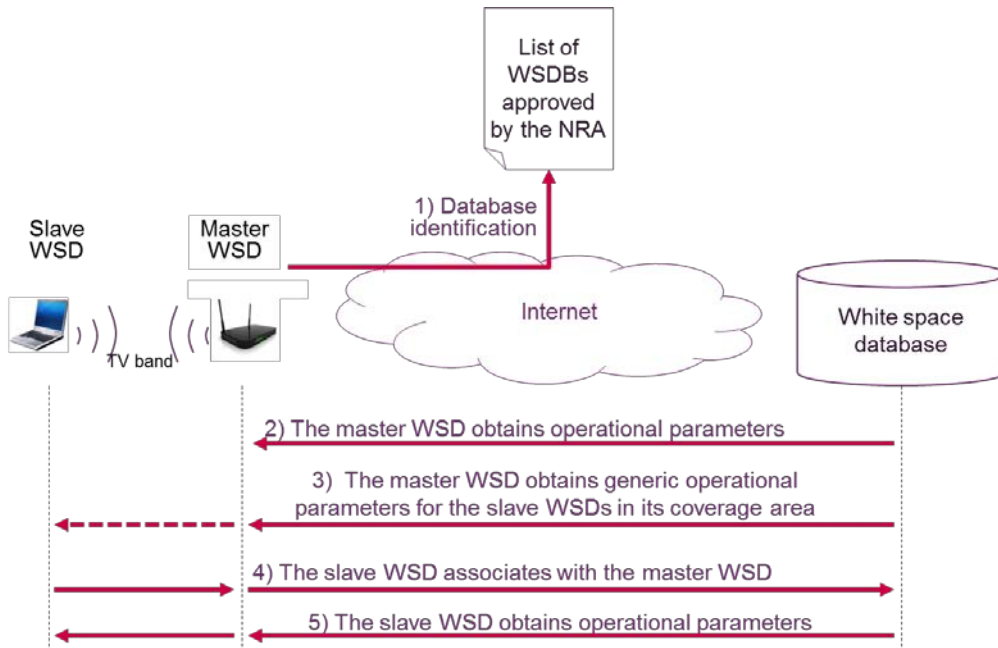

Figure 7: Sequence of events in the interactions

- 1 Database identification. The master WSD obtains the list of the WSDBs approved to operate in the regulatory domain. The list is hosted by the relevant NRA, and accessible over the internet. The master WSD selects a WSDB from the list for its operations;
- 2 Specific operational parameters for a master WSD. The master WSD communicates its device parameters to the chosen WSDB. The WSDB will generate the operational parameters on the basis of the information provided by the master WSD, and the information that it holds about the primary users. The operational parameters will include a range of channels and powers. The master device must select which of those it will use, and report its choice to the WSDB by means of the channel usage parameters. The device can then start transmissions;
- 3 Generic operational parameters for slave WSDs. These parameters identify the resources that any slave WSD in the coverage area of master WSD can use. The master WSD will make a request for these parameters to the WSDB. At this stage the WSDB does not know anything about the slave WSDs that could be using these parameters. The WSDB will use the information about the master WSD to calculate the master's coverage area, and then it calculate the generic operational parameters on the assumption that slaves could be at any location within the master's coverage area. The WSDB will then send the generic operational parameters to the master WSD, and the master WSD will broadcast them to its coverage area;
- 4 Association of a slave WSD with a serving master WSD. When switched on, a slave WSD will listen for a master's broadcasts. It will then use the channels and powers identified in the generic operational parameters to associate with the master WSD. This means that it will communicate its unique device identifier, or the full set of its device parameters. The slave WSD may now continue to use the radio resources identified in the generic operational parameters for data transmissions, or alternatively it may request specific operational parameters;
- 5 Specific operational parameters for a slave WSD. The radio resources allowed by the generic operational parameters will be limited because they are based on the conservative assumption that slave devices could be anywhere in the coverage area of the master. A slave WSD could get better access to the resources if it can provide additional information about itself, in particular its location. For this, a process similar to obtaining specific operational parameters for a master WSD will be followed.

The ETSI EN specifically requires that the master WSD contacts the web-list hosted by the NRA before reaching a WSDB, but it does not prescribe that the subsequent steps must occur in the order shown here, or that they must occur at all. For instance, it does not mandate that a slave device gets specific parameters - it may continue using the generic operational parameters for carrying traffic.

A1.1 DEVICE REQUIREMENTS IN EN 301 598

EN 301 598 [2] defines first the device types, then specifies a number of RF requirements, and finally includes a several non-RF requirements to deal with the fact that the radio parameters are communicated by a database.

A1.1.1 Device types

EN 301 598 [2] defines two types of WSDs:

- A Type A WSD is a device that is intended for fixed use only. This type of equipment can have integral, dedicated or external antennas.
- A Type B WSD is a device that is not intended for fixed use and which has an integral antenna or a dedicated antenna.

The classification corresponds to the applications that have so far have been identified. Professional installations, such as a base station serving rural broadband customers, will most likely be type A devices. Type-B WSDs correspond to mobile/portable equipment such as handsets, dongles, or access points which do not require installation and can be mass market. EN 301 598 requires these devices to have non-detachable antennas, to mitigate the risk of the end user tampering with the antenna.

A1.1.2 RF requirements

The RF requirements in EN 301 598 [2] address the prevention of harmful interference by ensuring that the wanted radiated power, and the unwanted radiated power (inside and outside the band) do not exceed specific limits. The specifications of limits outside the band are defined in the same manner as existing ENs.

On the other hand, the limits inside the UHF TV band are more complex. This is fundamentally because a WSD may operate in a single DTT channel, or simultaneously in a group of contiguous DTT channels, or in multiple non-contiguous DTT channels, or a mixture of contiguous and non-contiguous DTT channels. The EN includes requirements for the following parameters:

- Nominal channel A Nominal Channel is defined as one or more contiguous DTT channels that are used by a WSD for its wanted transmissions. The EN requirements are that;
 - The Nominal Channel Bandwidth used by a WSD shall not exceed the Maximum Nominal Channel Bandwidth specified by the WSDB;
 - The Total Nominal Channel Bandwidth, which is the sum of the bandwidth in all Nominal Channels, shall not exceed the Maximum Total Nominal Channel Bandwidth specified by the WSDB;
- In-block power and power spectral density. The requirement of EN 301 598 is that the device must not exceed the levels communicated by the WSDB;
- Unwanted emissions inside the band. The out-of-block e.i.r.p. spectral density, P_{OOB} , of a WSD shall satisfy the following requirement:

$$P_{OOB} \text{ (dBm / (100 kHz))} \leq \max \{P_{IB} \text{ (dBm / (8 MHz))} - \text{ACLR (dB)}, - 84 \text{ (dBm / (100 kHz))}\}$$

where P_{IB} is the in-block e.i.r.p. spectral density over 8 MHz, and ACLR is the adjacent channel leakage ratio. Each out-of-block e.i.r.p. spectral density is examined in relation to P_{IB} in the nearest (in frequency) DTT channel used by the WSD. The EN specifies 5 emissions classes with different OOB emissions masks.

A1.1.3 Data communication requirements

The objective of EN 301 598 is that the WSDs only communicate with approved WSDBs, and then provide the necessary device parameters to the WSDB and operate in accordance with the information received from the database.

The EN defines the contents of the operational parameters, the device parameters and the channel usage parameters, but their detailed specification (such as the format and size of the data) is left to the protocols that devices and WSDBs will use to communicate (such as IETF PAWS).

A1.1.3.1 Database identification

Database identification is the process by which a master WSD consults the list of WSDBs that have been approved by the relevant NRA for the provision of services at the geographical location of the master WSD.

At start up, and before initiating any transmissions, a master WSD must locate and consult the list. EN 301 598 further specifies that the master WSD must not transmit if it cannot consult the list, and that it must not request parameters from a WSDB that is not on the list. In addition, the master WSD must re-consult the list with a frequency that is specified in the list itself, and that would normally be in the order of one or several days.

The internet address for the lists for the various regulatory domains is provided in ETSI TR 103 231 [15].

A1.1.3.2 Data exchange and compliance with parameters

The dynamic nature of frequency and power allocations to WSDs led ETSI to specify precise requirements for the exchange of parameters between WSDBs and WSDs and subsequent compliance with OPs. The requirements are about what parameters a device is allowed to use, and what parameters it must communicate to other entities. These requirements can be summarised as follows:

- A WSD shall only transmit in accordance with operational parameters that it has received from a WSDB;

- A master or a slave WSD that require specific operational parameters from a WSDB must report their device parameters to the WSDB. A slave WSD that intends to use the generic operational parameters broadcasted by a master must report its unique device identifier (although it may report the rest of the device parameters if it wishes to);
- A master WSD must communicate its channel usage parameters to the WSDB prior to transmission, and slave device must do the same to the serving master WSD;
- A master WSD must relay the parameters between the WSDB and slave WSDs that it serves.

A1.1.3.3 Master and slave WSD update

NRAs have stated that it should be possible to switch off a device within a short time for interference management purposes. For this, EN 301 598 [2] requires a master WSD to support an update function, through which a WSDB can inform that the OPs of the master WSD and its served slave WSDs are no longer valid.

In addition, there are requirements to automatically stop transmissions when the connection between the master WSD and the WSDB is lost, and where the slave WSD stops receiving the signal of the serving master WSD.

A1.1.4 Other requirements

Accurate location of devices is an important element of operation under the framework. Also, special attention must be given to avoid the end user tampering with the elements of the device that are used in determining the operational parameters. The EN 301 598 includes specific requirements in these areas.

- Geo-location requirements: a master WSD must be able to geo-locate and report its location and location uncertainty to the WSDB. A slave WSD is not required to have this capability. In addition, WSDs which geo-locate must check its location at least every 60 seconds and renew the parameters if they move away from the location originally reported to the WSDB;
- User access restrictions and security measures: An important concern from the perspective of interference to incumbent primary services is the risk of users tampering with the WSDs. If a WSD user is capable of bypassing the process of receiving parameters from a WSDB, or is capable of inputting bogus device parameters into the WSD, then serious interference could result. For this reason, EN 301 598 [2] contains strict requirements to avoid the users gaining access to the configuration of the WSD, and to ensure that communications with a WSDB are secured and authenticated.

ANNEX 2: HIGH LEVEL DESCRIPTION OF THE TECHNICAL RULES IMPLEMENTED FOR THE UK PILOT FOR CALCULATION OF OPERATIONAL PARAMETERS

A2.1 IMPLEMENTATION OF TVWS RULES

The main task of an NRA is to ensure that incumbent users are protected. This is achieved by a set of rules that specify how the WSD availability is calculated by the WSDB. This section presents an example of the set of rules that a NRA may want to implement in practice. This section presents an example of how the coexistence frameworks in ECC Report 159 [3], ECC Report 185 [4] and ECC Report 186 [1] can be implemented in practice. The example is based on the UK model. Note however that:

- At the time of writing the databases that would support WSD in the UK were about to sign the contract with Ofcom and to go through a process of qualification. There may be differences between the descriptions in this document and the final requirements in the UK. The description here is based on the policy Statement that Ofcom published in February 2015¹⁹;
- The detail of the UK calculations is beyond the scope of this section, which presents a high level description. The reader interested in the comprehensive specification can use the Ofcom Statement, and other materials made available at Ofcom's website;
- The UK model is based on characteristics that may not be present in other jurisdictions, in particular;
 - UK Planning Model (UK PM) The UK has readily available information of the DTT coverage. Over the years the DTT community have developed detailed maps of the DTT signal levels at the populated locations of the UK;
 - PMSE information – PMSE use of the TV band in the UK is licensed. For PMSE use in DTT channels other than channel 38, the user must provide detailed information about the expected use – this includes time and location of operations, and the some technical characteristics of the PMSE equipment. Arqiva, acting on behalf of Ofcom, will coordinate PMSE assignments with DTT broadcasts and with other PMSE assignments. PMSE use in channel 38 is also licensed but it is not coordinated. In this case licenses allow PMSE use at any location in the UK over the duration of the licence which is one year;
 - DTT calculations – In the UK, the bulk of the calculations that generate the e.i.r.p. levels that WS devices is carried out by Ofcom. These calculations, described below, are very complex and Ofcom has taken the view that it is preferable to keep them in-house. A NRA may take the alternative approach and tasks the database provider with these calculations. In this case, these will be part of the agreement between the NRA and the provider.

The rest of this section covers is structured as follows:

First, it describes the calculations of the WSD e.i.r.p. levels to ensure protection of incumbents. We include here DTT in the UK, PMSE (coordinated and uncoordinated), users above and below the TV band, and DTT use in UK's international neighbours. The rules for the protection calculations are somewhat different for each of these incumbents:

- a) Protection of DTT in the UK: Ofcom calculates the maximum e.i.r.p. values that a WSD can use at all locations in the UK, for a combination of parameters;
- b) Protection of cross border DTT. Ofcom calculates the maximum e.i.r.p. values, and overlays this restriction over the datasets calculated for a);
- c) Protection of coordinated PMSE. Ofcom provides to the WSDBs the list of PMSE assignments, which includes the location and the technical characteristics of each assignment. On reception of a request for operational parameters from a WSD, the WSDBs calculate the maximum e.i.r.p. levels that ensure that no PMSE assignment in the list is interfered by the WSD;

¹⁹ <http://media.ofcom.org.uk/news/2015/tvws-statement/>

- d) Protection of uncoordinated PMSE in channel 38, and of users below and above the TV band (location agnostic limits). Ofcom calculates a table of WSD e.i.r.p. limits for each DTT channel, each WSD emission class, and each WS device type (i.e. type A and type B). These limits are location independent. The WSDB combines the limits from this table with the limits for protection of DTT, before providing the parameters to the device.

Second, the section explains how the WSDBs are required to deal with the uncertainty in the location of the WSD, and to combine the various limits that come out of the calculations in order to generate operational parameters that are compliant with the ETSI EN.

A2.1.1 Calculation of the WSD e.i.r.p. levels to ensure protection of incumbents

In this section we present a high-level description of the calculations necessary to derive the WSD regulatory emission limits in relation to other uses of the spectrum, and explain how and where these limits are combined. Figure 8 illustrates the various emission limits, and the entities responsible for their calculation

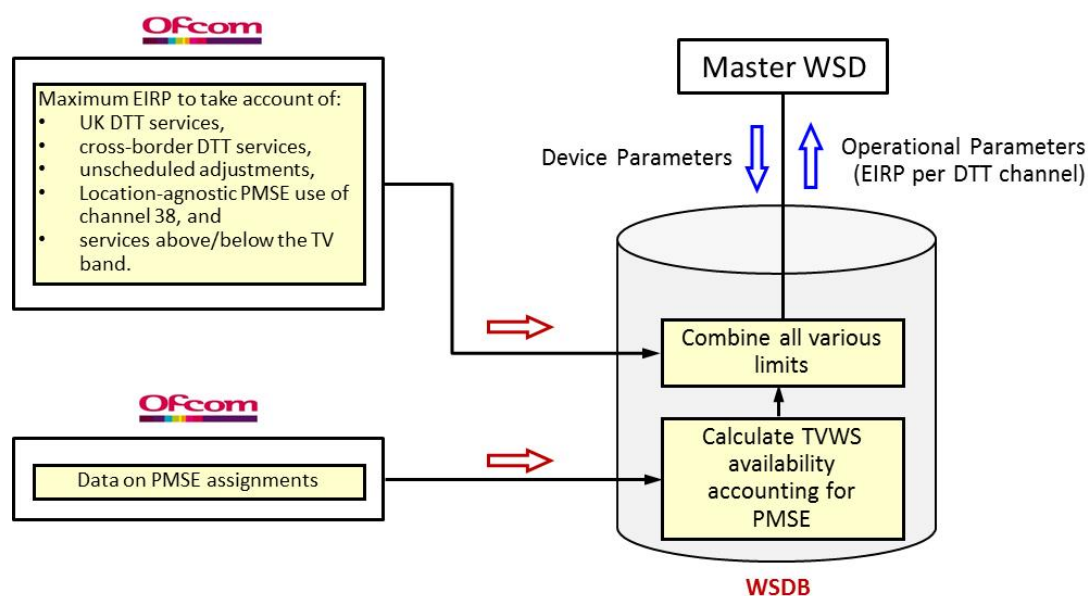

Figure 8: various emission limits, and the entities responsible for their calculation

A2.1.2 Emission limits for protection of DTT in the UK

The framework for access to TV white spaces in the UK is based on the premise that the impact of harmful interference on a DTT receiver is a function of the quality of the DTT coverage in the geographical area where the DTT receiver is located. The implication is that the regulatory emission limits for a WSD can be significantly increased in areas where the DTT signal-to-interference-plus-noise ratio (SINR) is high in the absence of WSDs. In other words, where the DTT coverage quality is good, WSDs can operate at higher powers.

Specifically, the derivation of location-specific TVWS availability can be formulated as the following problem:

Calculate the maximum permitted WSD in-block e.i.r.p., $P_{\text{WSD-DTT}}(i, F_{\text{WSD}})$, for a WSD located in a geographic pixel indexed as i , and radiating in channel F_{WSD} , subject to a given maximum reduction in DTT location probability in any channel $F_{\text{DTT}} = 21$ to 60 .

The limit $P_{\text{WSD-DTT}}(i, F_{\text{WSD}})$ is measured over 8 MHz, since DTT operates in 8 MHz channels. Also, in line with DTT planning in the UK, we use a spatial resolution that is based on 100 metre \times 100 metre geographic pixels ("pixels"). This results in over 20 million pixels to cover the UK.

Figure 9 shown an illustration of the regulatory e.i.r.p. limits at a given location.

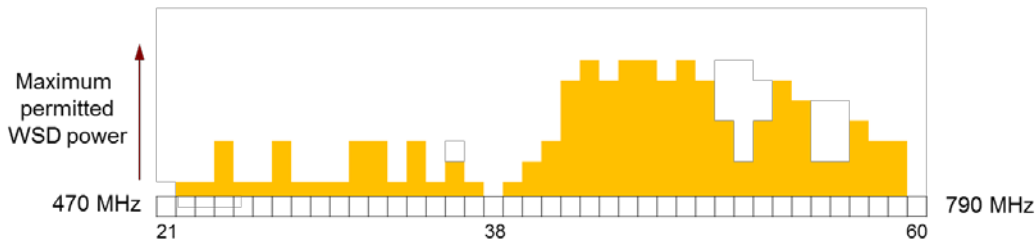

Figure 9: An illustration of WSD regulatory e.i.r.p. limits at a given location

The algorithm for calculation of the WSD limits is described next, using the following notation:

- i_{WSD} WSD transmitter location/pixel index;
- F_{WSD} WSD channel index, 21 to 60;
- i_{DTT} DTT receiver location/pixel index;
- F_{DTT} DTT channel index, 21 to 60;
- I_{DTT} DTT transmitter index.

The terms location and pixel are used interchangeably. The spatial resolution of the calculations is 100 metres. Table A2.1 describes how to calculate the maximum permitted WSD e.i.r.p.s at a given location i_{WSD} and in a given channel F_{WSD} in relation to various DTT receiver locations i_{DTT} , DTT channels F_{DTT} , and DTT transmitters I_{DTT} .

Table 2: High level structure of calculations

```

For each WSD location  $i_{WSD}$  in the UK
  → For each WSD channel  $F_{WSD} = 21 \dots 60$ 
  → → For each protected location  $i_{DTT}$  (relevant to  $i_{WSD}$ )
  → → → For each protected DTT transmitter  $I_{DTT}$  (relevant to  $i_{WSD}$ )
  → → → → For each protected DTT channel  $F_{DTT}$  (relevant to  $i_{DTT}$ )
  ¶
  → → → → Calculate WSD EIRP:  $P_{WSD}(F_{WSD}, F_{DTT}, i_{WSD}, i_{DTT}, I_{DTT})$ 
  → → → → ¶
  → → → → End ¶
  → → → End ¶
  → → End ¶
  → End ¶
End ¶
    
```

The term *protected* highlights the fact that it not necessary to examine every element in a parameter set. Specifically:

- If a DTT pixel is unpopulated, then it is by definition not protected, and we do not include it in our calculations;
- If a DTT pixel is served by certain protected TV transmitters via a number of protected DTT channels, then we do not include other DTT transmitters and channels in our calculations for that DTT pixel.

At each DTT receiver pixel i_{DTT} in the UK, Ofcom specifies a list of all serving DTT transmitters $\{l_{\text{DTT}}\}$ and protected DTT channels $\{F_{\text{DTT}}\}$. Note that while a DTT transmitter may provide service in a given DTT receiver location, it is possible that not all the channels in which it transmits are protected. This might be because for some channels the location probability (see later for definition) falls below a 70% threshold²⁰.

Example: The Hemel Hempstead DTT transmitter broadcasts on channels 41, 44, 47, 50, 55, and 59. Ofcom may specify that in a particular DTT receiver pixel the Hemel Hempstead is the serving DTT transmitter, but only channels 41, 44, 47, 50, and 55 are protected because their respective location probabilities exceeds 70%.

Furthermore, for a given WSD location i_{WSD} in the UK, it is not necessary to examine all DTT pixels in the UK, since a DTT pixel that is a large distance away would not affect the WSD regulatory limits, and as such is not relevant. For each WSD location i_{WSD} in the UK, a list of relevant DTT pixel locations $\{i_{\text{DTT}}\}$ can be calculated. Such DTT pixels will be defined as those that are a distance R_{REL} or less from the WSD location i_{WSD} , where distance is measured between the pixel centres. Ofcom is using a value of R_{REL} of 20 km for co-channel, and 2 km for adjacent channel calculations. [Example: If $R_{\text{REL}} = 20$ km, then $\{i_{\text{DTT}}\}$ will have [125,664] elements.]

Finally, a WSD is not allowed to operate co-channel with a DTT channel that is protected at the DTT receiver pixel. In other words, $P_{\text{WSD}}(F_{\text{WSD}}, F_{\text{DTT}}, i_{\text{WSD}}, i_{\text{DTT}}, l_{\text{DTT}}) = 0$ if $F_{\text{WSD}} = F_{\text{DTT}}$.

The WSD regulatory emission limit $P_{\text{WSD-DTT}}$ at location i_{WSD} and in channel F_{WSD} will be derived as:

$$P_{\text{WSD-DTT}}(i_{\text{WSD}}, F_{\text{WSD}}) = \min_{i_{\text{DTT}}, l_{\text{DTT}}, F_{\text{DTT}}} \left\{ P_{\text{WSD}}(i_{\text{WSD}}, F_{\text{WSD}}, i_{\text{DTT}}, l_{\text{DTT}}, F_{\text{DTT}}) \right\},$$

where minimisation is performed over all protected DTT receiver pixels, DTT transmitters, and DTT channels.

The output of this algorithm is a set of TVWS availability maps for protection of DTT. Ofcom generates a map for each combination of WSD emission class (5 in the current ETSI standard) and of a set of device heights (5 heights ranging from 1.5 metres to 20 metres). Each map provides the maximum e.i.r.p. that a WSD can use in each DTT channel and at each 100 meters x 100 metres pixel in the UK.

The following subsection outlines the approach for deriving the various parameters required for the calculation of $P_{\text{WSD}}(F_{\text{WSD}}, F_{\text{DTT}}, i_{\text{WSD}}, i_{\text{DTT}}, l_{\text{DTT}})$.

A2.1.3 Calculating P_{WSD}

The WSD e.i.r.p. $P_{\text{WSD}}(F_{\text{WSD}}, F_{\text{DTT}}, i_{\text{WSD}}, i_{\text{DTT}}, l_{\text{DTT}})$ will be calculated as a function of the coupling gain G , protection ratio r , and maximum permitted nuisance power Z . Specifically (in the linear domain),

$$P_{\text{WSD}} = \frac{Z}{rG}. \quad (\text{A2.2})$$

The parameters G , r and Z are defined next. Their detailed calculation is beyond the scope of this section and can be found in Ofcom Statement²¹.

²⁰ In the planning of the UK network, a pixel is considered served by DTT if the location probability for that pixel exceeds 70%. In calculating this location probability, the wanted received DTT signal power is predicted via 50%-time propagation models, while the unwanted received DTT signal powers are predicted via 1%-time propagation models.

²¹ <http://media.ofcom.org.uk/news/2015/tvws-statement/>

Coupling gain $G(F_{DTT}, i_{WSD}, i_{DTT}, I_{DTT})$

Coupling gain is the sum (in dB) of propagation gain (path loss) and DTT receiver antenna installation gain. In the Ofcom calculations, the coupling gain is calculated a function of

- a) the DTT channel F_{DTT} (path loss is frequency dependent);
- b) the WSD and DTT receiver antenna locations i_{WSD} and i_{DTT} (path loss is a function of the geographic separation between the WSD transmitter and DTT receiver), and
- c) the protected DTT transmitter (identifies the pointing angle of the household's DTT receiver antenna, and hence the appropriate antenna angular discrimination).

Ofcom uses the SEAMCAT Hata propagation model and classification of DTT receiver locations in three tiers, depending on their position relative to the WSD location.

Protection ratio $r(F_{WSD}, F_{DTT}, i_{DTT}, I_{DTT})$

Protection ratio specifies the ratio of received wanted over unwanted power at the point of receiver failure. Protection ratio is defined by the adjacent channel leakage ratio (ACLR) of the interferer and the adjacent channel selectivity (ACS) of the receiver.

Protection ratio is a function of

- d) the separation between the WSD channel and DTT channel, $\Delta F = F_{WSD} - F_{DTT}$, since both ACLR and ACS are also functions of ΔF , and
- e) the location of the DTT receiver and the serving TV transmitter, since ACS reduces (protection ratio increases) with increasing levels of DTT signal power as the receiver overloads.

The ACLR of a WSD is characterised by the five emission classes specified in the ETSI harmonised standard EN 301 598 [2].

The ACS characterises the overall behaviour of the receiver in response to the adjacent channel interferer, and captures effects ranging from frequency discrimination (i.e., various stages of filtering) to receiver susceptibility to the interferer's signal structure (e.g., inability of the receiver's automatic gain control to respond to large fluctuations in the interferer's power). Ofcom has evaluated in a test bench the ACS performance of 50 DTT receivers in the UK market, and taken the 70th percentile value of the ACS measurements.

Protection ratios are modelled for each class of WSD device and for different frequency separations.

Maximum permitted nuisance power $Z(i_{DTT}, F_{DTT}, I_{DTT})$

The maximum permitted nuisance power relates to the maximum amount of unwanted power a DTT receiver can tolerate.

The maximum permitted nuisance power is a function of

- a) the DTT receiver location i_{DTT} ;
- b) the DTT channel F_{DTT} , and
- c) the DTT transmitter I_{DTT} ,

and its value depends on the quality of DTT coverage, as described by the UKPM. Ofcom has calculated Z for each protected DTT location i_{DTT} (i.e. every populated pixel in the UK), for each protected DTT transmitter I_{DTT} , and for each "protected" DTT channel F_{DTT} . A detailed description of how Z is calculated can be found in Ofcom's statement

A2.1.4 Emission limits for protection of cross border UK

In the relation to cross border DTT, the derivation of location-specific TVWS availability can be formulated as the following problem:

Calculate the maximum permitted WSD in-block e.i.r.p., $P_{WSD-XB}(i, F_{WSD})$, for a WSD located in a geographic pixel indexed as i , and radiating in channel F_{WSD} , subject to the received field strength in neighbouring countries not exceeding relevant international coordination trigger threshold in channel F_{WSD} .

The limit $P_{WSD-XB}(i, F_{WSD})$ is measured over 8 MHz, since DTT operates in 8 MHz channels. Again, in line with DTT planning in the UK, we use a spatial resolution that is based on 100 metre \times 100 metre geographic pixels ("pixels").

Ofcom will be responsible for generating TVWS availability datasets in relation to cross border DTT. This dataset will be combined by Ofcom with the dataset for protection of DTT in the UK, in order to provide to WSDB a dataset of values for P_1 . P_1 is the Maximum in-block RF e.i.r.p. for a DTT channel, defined in the ETSI standard as one of the operational parameters that a WSDB provides to a WSD.

A2.1.5 Calculation of location agnostic limits

Location-agnostic WSD emission limits apply in the context of seeking to ensure a low probability of harmful interference to uses above and below the UHF TV band, as well as PMSE usage in channel 38.

These limits are not location-specific because information on the locations of the above uses is not available and therefore cannot be exploited in a database-assisted framework for access to TV white spaces. As a result, the WSD emission limits are simply specified by Ofcom as location-agnostic limits, $PLA(F_{WSD})$, in each channel $F_{WSD} = 21 \dots 60$.

The limit $P_{WSD-LA}(F_{WSD})$ is measured over 8 MHz.

A2.1.6 Combining of emission limits by Ofcom

As described above, Ofcom calculates the limits $P_{WSD-DTT}(i, F_{WSD})$, $P_{WSD-XB}(i, F_{WSD})$, and $P_{WSD-LA}(F_{WSD})$, all measured over 8 MHz, in the context of interference to UK DTT, cross border DTT, and PMSE use in channel 38 as well as uses immediately outside the UHF TV band, respectively. Ofcom will calculate the overall e.i.r.p. limit as

$$P_1(i, F_{WSD}) = \min \left\{ P_{WSD-DTT}(i, F_{WSD}), P_{WSD-XB}(i, F_{WSD}), P_{WSD-LA}(F_{WSD}) \right\}$$

measured in dBm/(8 MHz). That is to say, the restrictions relating to cross border DTT, uses in channel 38, and outside the UHF TV band, will be applied as an overlay on the restrictions relating to DTT in the UK. Ofcom will then communicate the values of $P_1(i, F_{WSD})$ to the WSDBs

Ofcom generates a unique TVWS availability dataset for each combination of the five WSD spectrum emission classes in ETSI EN 301 598 and a number of representative WSD antenna heights, all for type A WSDs. TVWS availability for type B devices will be inferred by WSDBs from availability for type A devices. Each dataset contains contain the $P_{WSD-DTT}$ value for each DTT channel at each of 100 metres \times 100 metres pixel in in the UK

A2.1.7 Emission limits for protection of PMSE

The approach to protection of PMSE is somewhat different from DTT. Here, absent information on the details of a deployment, we consider the quality of PMSE reception to be the same at every venue. However, the regulatory emission limits for a WSD can be significantly increased the further the WSD is located geographically from a PMSE receiver.

Specifically, the derivation of location-specific TVWS availability can be formulated as the following problem:

Calculate the maximum permitted WSD in-block e.i.r.p., $P_{\text{WSD-PMSE}}(j, F_{\text{WSD}})$, for a WSD located in a geographic location indexed as j , and radiating in channel F_{WSD} , subject to a given PMSE wanted-to-unwanted power ratio in any channel $F_{\text{DTT}} = 21$ to 60 .

The limit $P_{\text{WSD-PMSE}}(j, F_{\text{WSD}})$ is measured over 100 kHz, since the vast majority of PMSE equipment operate in bandwidths of 200 kHz or less, and so a finer resolution than 8 MHz is required.

WSDBs will be responsible for performing the above calculations. The WSDB receives from the requesting WSD the characteristics of the WSD, including location and the device parameters such as emission class or type. Ofcom provides the WSDB with a list of PMSE assignments including detailed characteristics of each assignment, such as location and equipment type. Ofcom also provides the WSDB with a list of PMSE venues and the contours of those venues. If a PMSE assignment is associated with a venue, the WSDB will make the assumption that the PMSE receiver could be anywhere within the venue, and calculate protection accordingly.

The WSDB calculate protection limits for each potential PMSE victim, and take into account the uncertainty in the location of the WSD. This aspect is described below.

$P_{\text{WSD-PMSE}}$ is calculated as the minimum of the following limits:

$P_{\text{WSD_PR_PMSE}}$ in dBm/(100 kHz), an EIRP spectral density limit to ensure a low probability of “direct” transmissions from the WSD to the PMSE receiver causing harmful interference; and

$P_{\text{WSD-PMSE-PMSE}}$ in dBm/(100 kHz), an EIRP spectral density limit to ensure a low probability of “PMSE transmit intermodulation” interference (generated in response to interference from the WSD) causing harmful interference; and

a 36 dBm/8 MHz cap i.e. 16.97 dBm/100 kHz.

that is:

$$P_{\text{WSD-PMSE(dBm/(100kHz))}} = \min\{P_{\text{WSD_PR_PMSE}}, P_{\text{WSD_PMSE_PMSE}}, 16.96\}$$

$P_{\text{WSD_PR_PMSE}}$ in a specific DTT channel and at a specific WSD candidate location shall be calculated according to:

$$P_{\text{WSD_PR_PMSE}} = P_{\text{S,0 (dBm/B)}} - r(\Delta F)_{\text{(dB)}} - m_{\text{G1(dB)}} - \gamma_{\text{(dB)}} - 10\log_{10}(80)$$

where

$P_{\text{S,0}}$ is the wanted PMSE received signal power (over bandwidth B),

B is the nominal channel bandwidth of the PMSE device,

m_{G1} is the WSD-to-PMSE median coupling gain,

$r(\Delta F)$ is the WSD-to-PMSE protection ratio defined as the ratio of PMSE received wanted signal power (in dBm/(B kHz)) over WSD received unwanted signal power (in dBm/(8 MHz)) at the point of PMSE receiver failure,

ΔF is the WSD-to-PMSE DTT channel separation (in units of 8 MHz),

γ is a margin (≥ 0 dB),

$10\log_{10}(80)$ converts the calculated EIRP from a bandwidth of 8 MHz to a bandwidth of 100 kHz

$P_{\text{WSD-PMSE-PMSE}}$ in dBm/(100 kHz), shall be calculated according to:

$$P_{\text{WSD-PMSE-PMSE}} = P_{\text{I,T (dBm/B)}} - m_{\text{G2(dB)}} - m_{\text{G3(dB)}} - C_{\text{IM1}} - 10\log_{10}(80)$$

where

$P_{\text{I,T}}$ is the target received interference at PMSE (over bandwidth 200 kHz),

m_{G2} is the median coupling gain between WSD and the PMSE transmitter which is generating the PMSE transmit intermodulation interference,

m_{G3} is the median coupling gain between PMSE transmitter which is generating the PMSE transmit intermodulation interference and the victim PMSE receiver,

C_{IM1} is an adjustable parameter for intermodulation product.

$10\log_{10}(80)$ converts the calculated EIRP from a bandwidth of 8 MHz to a bandwidth of 100 kHz

A2.2 CALCULATION OF OPERATIONAL PARAMETERS

A2.2.1 Operational parameters and device parameters

The UK framework is based on exchange of the following parameter sets between a WSDB and a WSD. These parameter sets are in line with the definitions in ETSI EN 301 598.

Table 3: Operational parameters

Parameters	Description
Lists of DTT channel edge frequency pairs	This is the list of frequency blocks where the TVWSD is allowed to transmit
Maximum in-block RF e.i.r.p. spectral density for each DTT channel edge frequency pair	$P_{0,i}$ (dBm / (0,1 MHz)) over the frequency interval $f_{L,i}$ to $f_{U,i}$
Maximum in-block RF e.i.r.p. for each DTT channel edge frequency pair	$P_{1,i}$ (dBm) over the frequency interval $f_{L,i}$ to $f_{U,i}$
Maximum nominal channel bandwidth	Maximum contiguous bandwidth (in Hz) allowed
Maximum total bandwidth	Maximum total bandwidth (in Hz) allowed, which may or may not be contiguous
Time validity start (T_{ValStart})	Time when the operational parameters start being valid
Time validity end (T_{ValEnd})	Time when the operational parameters stop being valid
Location validity (L_{Val})	Radius (in metres) of the circle centred on the reported location of the TVWSD, outside of which the operational parameters are not valid
Simultaneous channel operation power restriction	Can take values of 0 or 1. A value of 1 indicates the device that the power restriction in clause 4.2.3.2 of the EN applies, a value of 0 indicates that the power restriction does not apply. The default value is 0
Update timer (T_{Update})	This timer indicates how often (in seconds) the master TVWSD shall check with the TVWSDB that the operational parameters are still valid

Table 4: Device parameters

Parameter Name	Description
Antenna location	Latitude and longitude coordinates and altitude, e.g. in WGS84 format.
Antenna location uncertainty	Latitude, longitude, and altitude uncertainties specified as $\pm\Delta x$, $\pm\Delta y$ and $\pm\Delta z$ metres respectively, corresponding to a 95 % confidence level.
Device type	Type A or Type B.
Device category	Master or slave.
Unique device identifier	A set of characters that allows to uniquely identify a device
Technology identifier	A set of characters representing that allows to uniquely identifying the technology. This may include: name of the organisation responsible for the technology specifications; specification number, version and issue date.
Device Emission class	Class 1, Class 2, Class 3, Class 4 or Class 5. The device emission class number reported by the TVWSD to the TVWSDB is the Class with which the device complies with as specified in table 3.

This section presents an overview of how a WSDB operating in the UK would calculate specific operational parameters. Some of the detailed elements of the algorithm are omitted for clarity but can be consulted on Ofcom's reference.

Specific operational parameters are operational parameters that a WSDB calculates using the device parameters of a specific WSD as input. A WSDB will only provide specific operational parameters for a TVWSD if it has received the device parameters of that WSD²².

The UK framework also supports operation according to generic operational parameters. These can be used by any slave device located in the coverage area of a master device, even if the precise location of the slave is not available. WSDBs will calculate generic operational parameters on the basis of the location of the serving master device, and an estimation of its coverage area. The rules for calculation of generic operational parameters are not described here and but be obtained from Ofcom website.

The device parameters that a WSDB requires in order to calculate specific operational parameters are considered in the following section.

A2.2.2 Calculation of specific operational parameters for a master WSD

List of available DTT channels

This is the indexes of all DTT channels in the UHF TV band, i.e. channels 21 to 60 that the Master WSD may use. Where Ofcom decides that certain channels are not available for use by WSDs, Ofcom will inform the WSDBs and the channels will be excluded from the list. Furthermore, a WSDB may choose not to provide

²² The ETSI standard also defines Generic operational parameters, which are the operational parameters that any slave TVWSD in the coverage area of a serving master TVWSD can use. A WSDB will provide generic operational parameters to a master TVWSD, and the master will broadcast these parameters for all slave WSDs in its coverage area. The WSDB will calculate generic operational parameters using, as input, the device parameters of the master WSD and a set of assumptions about the slave WSDs. WSDBs operating in the UK are also required to calculate generic operational parameters. The detail about how this is done is in the Ofcom documentation

Operational Parameters for a certain subset of DTT channels, in which case these may also be excluded from the list of available DTT channels.

Maximum permitted in-block e.i.r.p. P_1 in dBm/(8 MHz) in each DTT channel

This limit is calculated to ensure a low probability of harmful interference to DTT and other services with the exception of location-specific PMSE, on the basis of the reported horizontal location (x,y) and location uncertainty (Δx , Δy) reported by the Master WSD (as well as other Device Parameters).

The WSDB shall use the reported horizontal location and location uncertainty of the Master WSD to define a geographical area within which the Master WSD might be located (the area of potential locations).

The 100 metres x 100 metres pixels in the UK NGR which totally or partially overlap with the area of potential locations will be designated as WSD candidate pixels. This is shown in the figure below:

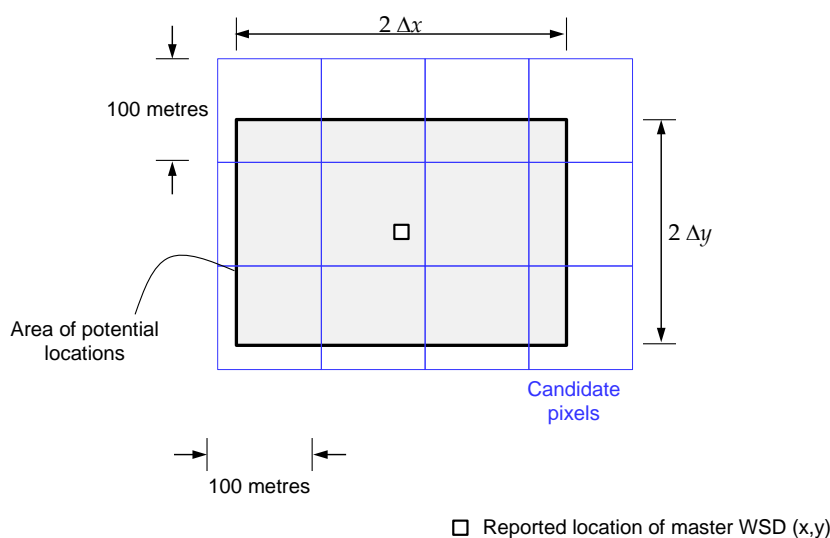

Figure 10: Candidate pixels for calculation of the maximum permitted in-block e.i.r.p. for a Master WSD

For each candidate pixel, i , and each channel, F , in the list of available DTT channels, the WSDB shall look up the P_{DTT} value in the datasets provided by Ofcom. The following parameters will also be used for the look up:

- The Master WSD emission class reported by the device;
- The height reported by the device.

If the a candidate pixel is not included in the DTT datasets, i.e. the pixel is outside the geographical area provided by Ofcom, then the P_{DTT} value for that pixel in 0 mW in all DTT channels.

Repeating the above for each candidate pixel and each available channel, the result will be a number of e.i.r.p. values $P_{DTT}(i,F)$.

For an available channel F_0 , $P_{DTT}(F_0)$ will be the smallest of the $P_{DTT}(i,F_0)$ values over the candidate WSD pixels.

The WSDB shall next calculate $P_1(F_0)$ as the minimum of:

- 36 dBm
- $P_{DTT}(F_0)$ as calculated above
- $P_{LA}(F_0)$, the location agnostic limit for that channel. $P_{LA}(F_0)$ accounts for protection of spectrum use above and below the TV band, and for protection of PMSE use in channel 38. The limit is a function of

the emission class of the device, the type of the device and the channel. The WSDB shall look up $P_{LA}(F_0)$ from the table in schedule.

- $P_{UA}(F_0)$, the unscheduled adjustment limit that Ofcom may introduce at any time for certain locations. If the location reported by the Master WSD is within any of the unscheduled adjustment regions provided by Ofcom, then $P_{UA}(F_0)$ is the limit in the unscheduled adjustment file for that region for that channel.

Maximum permitted in-block e.i.r.p. spectral density P_0 in dBm/(100 kHz) in each DTT channel

The value of P_0 at a specific DTT channel is calculated by the WSDB as the minimum of two values, one for protection of DTT derived from P1 above, and one for protection of PMSE, PWSD-PMSE, calculated as described in the following paragraphs;

As above, the WSDB shall use the reported horizontal location and location uncertainty of the Master WSD to define a geographical area within which the WSD might be located (the area of potential locations);

The WSDB shall evaluate PWSD-PMSE at a set of candidate locations. The candidate locations shall correspond to those grid points whose squares totally or partially overlap with the area of potential locations of a WSD. The grid itself shall be aligned with the NGR grid and shall have a resolution D of 10 metres. This shown in the Figure 11:

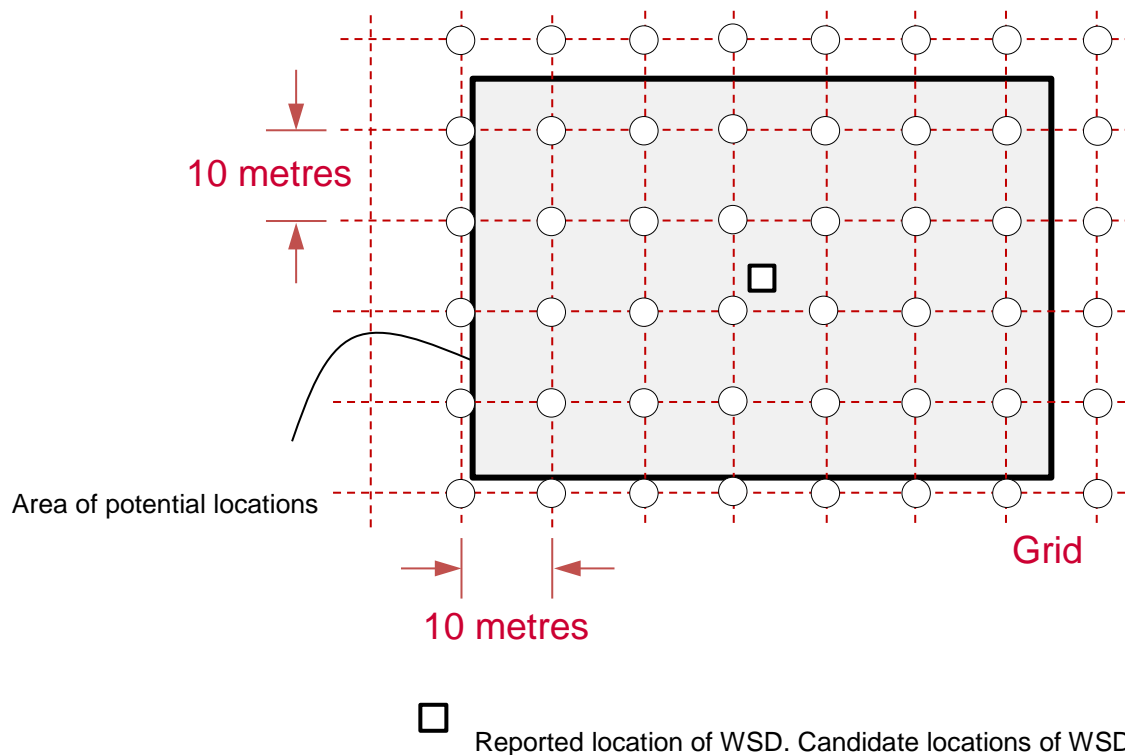

Figure 11: Candidate locations for calculation of the Maximum permitted in-block e.i.r.p. spectral density to ensure a low probability of harmful interference to PMSE, PWSD-PMSE

For each PMSE assignment which is active at any point in time between the Time validity start ($T_{ValStart}$) time and the time validity end (T_{ValEnd}) time of the operational parameters:

For each candidate location, i , and each channel, F , in the list of available DTT channels, the WSDB shall calculate the maximum permitted in-block e.i.r.p. spectral density according to the procedure in A2.1.6. The following parameters are used:

- The WSD emission class;
and
- WSD antenna height.

Repeating the procedure in A2.1.6 for each candidate Master WSD location and each available channel, the result will be a number of e.i.r.p. spectral density values $P_{\text{WSD-PMSE}}(i,F)$ for protection of a specific PMSE assignment.

For an available channel, F_0 , the WSDB shall then derive the maximum permitted e.i.r.p. spectral density $P_{\text{WSD-PMSE}}(F_0)$ as the smallest of the $P_{\text{WSD-PMSE}}(i,F_0)$ values, over the candidate WSD locations and over the different PMSE assignments.

For each PMSE assignment, it may be possible to identify $P_{\text{WSD-PMSE}}(F_0)$ without having to exhaustively calculate $P_{\text{WSD-PMSE}}(i,F_0)$ at all candidate locations – for instance by evaluating $P_{\text{WSD-PMSE}}(i,F_0)$ at a limited number of candidate locations that are geographically closest to the PMSE victims, in the absence of unscheduled adjustments. The WSDB may optimise its processes in this way provided that the $P_{\text{WSD-PMSE}}(F_0)$ obtained is equal to the value obtained through the exhaustive procedure.

It may also be possible to identify the PMSE assignments which are close enough to the WSD to be relevant for the calculations, and hence limit the PMSE assignments that are evaluated against.

Finally, the e.i.r.p. spectral density $P_0(F_0)$ in dBm/(100 kHz) included in the WSD Operational Parameters will be the minimum of the following two values:

- a) $P_{\text{WSD-PMSE}}(F_0)$, and
- b) $P_1(F_0) - 10\log_{10}(80)$, where $P_1(F_0)$ is the maximum permitted in-block e.i.r.p. calculated above.

Time validity start and time validity end

The time validity of the Operational Parameters will normally be defined by changes in the PMSE usage. The WSDB may decide on the start and end times of the validity of a particular operational parameter set. However the WSDB shall ensure that all PMSE assignments that are active during the time interval defined by T_{ValStart} and T_{ValEnd} are accounted for and protected.

Rest of parameters

- The WSDB must set the following operational parameters to the values provided by Ofcom;
- Location validity;
- Maximum permitted nominal channel bandwidth;
- Maximum total bandwidth;
- Update timer;
- Simultaneous channel operation power restriction.

ANNEX 3: INFORMATION ON DYNAMIC SPECTRUM ALLIANCE

The Dynamic Spectrum Alliance²³, whose members include industry and academia, was formed in 2012 to promote awareness of the benefits from dynamic spectrum access and best practice exchange between those developing enabling regulations. The DSA recognises that developing these regulations can be a daunting prospect for some administrations and has therefore produced a summary of what it sees as best practice so far – drawing on the regulatory frameworks developed by FCC in the US and Ofcom in the UK.

Although the rules are focussed on enabling licence-exempt access to the TV white spaces, the principles and general approach are considered applicable to white spaces in other bands.

The model rules:

- Identify the core issues to be addressed by regulation;
- Present relevant options for implementation of a framework;
- Focus on the use geo-location databases to facilitate licence-exempt access to unused spectrum (e.g. TV white spaces), but also present spectrum sensing is as an option that regulators may wish to consider;
- Allow for variable transmission power and fixed power approaches for white space devices (the latter being used by the FCC).

The [DSA website](#) hosts three documents introducing and describing the rules in detail:

- [Background and Context to the Model Rules](#);
- [Suggested Technical Rules and Regulations for the Use of Television White Spaces](#);
- [Frequently Asked Questions](#);

²³ <http://www.dynamicspectrumalliance.org>

ANNEX 4: LIST OF REFERENCE

- [1] ECC Report 186: Technical and operational requirements for the operation of white space devices under geo-location approach
- [2] ETSI EN 301 598: White Space Devices (WSD); Wireless Access Systems operating in the 470 MHz to 790 MHz frequency band; Harmonised EN covering the essential requirements of article 3.2 of the R&TTE Directive
- [3] ECC Report 159: Technical and operational requirements for the possible operation of cognitive radio systems in the 'white spaces' of the frequency band 470-790 MHz
- [4] ECC Report 185: Complementary Report to ECC Report 159. Further definition of technical and operational requirements for the operation of white space devices in the band 470-790 MHz
- [5] ETSI TR 102 907: Use Cases for Operation in White Space Frequency Bands
- [6] ETSI TS 102 946: System requirements for Operation in UHF TV Band White Spaces
- [7] ETSI TS 103 145: System Architecture and High Level Procedures for Coordinated and Uncoordinated Use of TV White Spaces
- [8] ETSI TS 103 143: System architecture for information Exchange between different Geo-Location databases (GLDB's) enabling the operation of White Space Devices (WSDs)
- [9] ETSI EN 303 144: Parameters and procedures for information exchange between different GLDBs
- [10] ETSI EN 303 387-1: Signalling Protocols and information Exchange for Coordinated use of TV White Spaces; part 1: Interface between Cognitive Radio System (CRS) and Spectrum Coordinator (SC)
- [11] ECC Report 132: Light Licensing, Licence-Exempt and Commons
- [12] IEEE 802.19.1-2014: Standard for Information technology- Telecommunications and information exchange between systems - Local and metropolitan area networks - Specific requirements - TV White Space Coexistence Methods
- [13] IEEE 802.11af: Standard for Information Technology - Telecommunications and Information Exchange Between Systems - Local and Metropolitan Area Networks - Specific Requirements - Wireless LAN Medium Access Control (MAC) and Physical Layer (PHY) Specifications- TV White Spaces Operation
- [14] CEPT Report 24: "Technical considerations regarding harmonisation options for the Digital Dividend". A preliminary assessment of the feasibility of fitting new/future applications/services into non-harmonised spectrum of the digital dividend (namely the so-called "white spaces" between allotments)
- [15] ETSI TR 103 231: White Space Devices (WSD); Wireless Access Systems operating in the 470 MHz to 790 MHz TV broadcast band; Information on web-listings of TV White Space Databases (TWWSDBs)