



# ECC Report 219

Characteristics of PMSE digital video links to be used in compatibility and sharing studies

Approved October 2014

## **0 EXECUTIVE SUMMARY**

There are a wide range of video PMSE applications and many further operational scenarios. However, for the purposes of sharing and compatibility studies, these cases have been reduced to 11 combinations of parameters, based on applications and height configurations. In order to determine the use-cases that may be permitted, each of these 11 combinations should be used in studies, except for studies for spectrum below 5 GHz which do not need to include the four combinations related to temporary point-to-point links.

## TABLE OF CONTENTS

<b>0 EXECUTIVE SUMMARY .....</b>	<b>2</b>
<b>1 INTRODUCTION.....</b>	<b>5</b>
<b>2 APPLICATIONS .....</b>	<b>7</b>
<b>3 PMSE WIRELESS VIDEO LINK CHARACTERISTICS TO BE USED IN SHARING AND COMPATIBILITY STUDIES .....</b>	<b>10</b>
3.1 Cordless camera link.....	10
3.2 Portable video link.....	11
3.3 Mobile video link.....	12
3.4 Temporary point-to-point video link.....	15
<b>4 CONCLUSIONS.....</b>	<b>16</b>
<b>ANNEX 1: INDICATIVE ANTENNA PATERNS .....</b>	<b>17</b>
<b>ANNEX 2: LIST OF REFERENCES .....</b>	<b>22</b>

## LIST OF ABBREVIATIONS

<b>Abbreviation</b>	<b>Explanation</b>
<b>AGL</b>	Above Ground Level
<b>AVC</b>	Advanced Video Coding
<b>BER</b>	Bit Error Rate
<b>C/N</b>	carrier-to-noise ratio
<b>C/(I+N)</b>	carrier-to-(interference + noise) ratio
<b>CCL</b>	Cordless Camera Link
<b>CEPT</b>	European Conference of Postal and Telecommunications Administrations
<b>COFDM</b>	Coded Orthogonal Frequency Division Modulation
<b>DVB-S2</b>	Digital Video Broadcasting - Satellite second generation
<b>DVB-T</b>	Digital Video Broadcasting - Terrestrial
<b>DVB-T2</b>	Digital Video Broadcasting - Terrestrial second generation
<b>ECC</b>	Electronic Communications Committee
<b>ENG</b>	Electronic News Gathering
<b>ETSI</b>	<a href="http://www.etsi.org">European Telecommunications Standards Institute</a>
<b>f/s</b>	frames per second
<b>HD</b>	High Definition
<b>HDTV</b>	High Definition Television
<b>HEVC</b>	High Efficiency Video Coding
<b>ISDB-T</b>	Integrated System for Digital Broadcasting - Terrestrial
<b>JPEG2000</b>	Joint Program Experts Group 2000
<b>LMS-T</b>	Link Modulation System - Terrestrial
<b>MIMO</b>	Multiple-Input-Multiple-Output
<b>MPEG2</b>	Moving Pictures Expert Group 2
<b>MPEG4</b>	Moving Pictures Expert Group 4
<b>MRC</b>	Maximum Ratio Combining
<b>MVL</b>	Mobile Video Link
<b>OB</b>	Outside Broadcast
<b>PMSE</b>	Programme Making and Special Events
<b>PVL</b>	Portable Video Link
<b>QEF</b>	Quasi error free
<b>RF</b>	Radio Frequency
<b>Rx</b>	Receiver
<b>SAB</b>	Services Ancillary to Broadcasting
<b>SAP</b>	Services Ancillary to Programme making
<b>Tx</b>	Transmitter
<b>UAV</b>	Unmanned Aerial Vehicle

## 1 INTRODUCTION

The term Programme Making<sup>1</sup> and Special Events<sup>2</sup> applications (PMSE) describes radio applications used for SAP/SAB, ENG/OB and applications used in meetings, conferences, cultural and education activities, trade fairs, local entertainment, sport, religious and other public or private events for perceived real-time presentation of audiovisual information.

The definitions of SAP/SAB and ENG/OB are set out as follows:

**SAP:** Services Ancillary to Programme making (SAP) support the activities carried out in the making of “programmes”, such as film making, advertisements, corporate videos, concerts, theatre and similar activities not initially meant for broadcasting to general public.

**SAB:** Services Ancillary to Broadcasting (SAB) support the activities of broadcasting industry carried out in the production of their program material.

The definitions of SAP and SAB are not necessarily mutually exclusive. Therefore they are often used together as “SAP/SAB” to refer generally to the whole variety of services to transmit sound and video material over the radio links.

**ENG:** Electronic News Gathering (ENG) is the collection of video and/or sound material by means of small, often hand-held wireless cameras and/or microphones with radio links to the news room and/or to the portable tape or other recorders.

**OB:** Outside broadcasting (OB) is the temporary provision of programme making facilities at the location of on-going news, sport or other events, lasting from a few hours to several weeks. Mobile and/or portable radio links are required for wireless cameras or microphones at the OB location. Additionally, radio links may be required for temporary point to point connections between the OB vehicle, additional locations around it, and the studio.

The definitions of ENG and OB are not mutually exclusive and certain operations could equally well reside in either or both categories. Therefore, it has been a long practice within the CEPT to consider all types of such operations under the combined term “ENG/OB”. It is also understood that ENG/OB refers to terrestrial radio communication services, as opposed to SNG/OB term, which refers to similar applications but over the satellite radio communication channels.

The SAP/SAB applications include both ENG/OB and SNG/OB applications, but also the communication links that may be used in the production of programmes, such as talk-back or personal monitoring of soundtrack, telecommand, telecontrol and similar applications.

ECC Report 204 [1] provides background information on the use of video PMSE.

Due to technology developments in video PMSE applications, namely the move to digital coding and transmission schemes, there is a requirement to provide information on these systems to assist CEPT with sharing and compatibility studies between video PMSE and other services.

Digital video links are now the industry standard for PMSE use. This Report provides technical characteristics, which should be used in any future compatibility studies. The tables provide information for the various forms of vision equipment and recommends that temporary Point to Point video links are not considered for study in bands below 5 GHz.

<sup>1</sup> *Programme Making* includes the making of a programme for broadcast, the making of a film, presentation, advertisement or audio or video recordings, and the staging or performance of an entertainment, sporting or other public event.

<sup>2</sup> A *Special Event* is an occurrence of limited duration, typically between one day and a few weeks, which take place on specifically defined locations. Examples include large cultural, sport, entertainment, religious and other festivals, conferences and trade fairs. In the entertainment industry, theatrical productions may run for considerably longer.

The demands for higher video quality have resulted in a multitude of modulation techniques and other parameters for all classes of video PMSE equipment. This Report condenses these parameters to provide a typical set of values to be used in studies for each class of equipment.

As Video PMSE is normally a licensed service the parameters, such as power for an individual event or activity can be adjusted via the licence conditions for future bands.

## 2 APPLICATIONS

The applications of digital video PMSE to be considered in sharing and compatibility studies are shown in Table 1.

**Table 1: Categories of PMSE video links in regular use**

Type of link	Definition
Radio camera (line-of-sight)	Handheld or otherwise mounted camera with integrated or Clip-on transmitter, power pack and antenna for carrying broadcast-quality video together with sound signals over short-ranges line-of-sight
Radio cameras (non-line-of-sight)	Handheld or otherwise mounted camera with integrated or Clip-on transmitter, power pack and antenna for carrying broadcast-quality video together with sound signals over short-ranges non-line-of-sight
Miniature camera/links	Very small transmitter and miniature camera for specialist action shots, e.g. helmet cam, covert assignments, UAV, etc. Can be body worn or covert assignments.
Portable video link	Small transmitter, for deployment over greater ranges, typically up to 2km
Mobile air-to-ground video link	Video transmission system employing radio transmitter and receivers mounted on helicopters, airships or other aircraft.(includes repeaters and relays)
Mobile vehicular video link (including ground-to-air)	Video transmission system employing radio transmitter mounted in/on motorcycles, racing motorbikes, pedal cycles, cars, racing cars or boats. One or both link terminals may be used while moving.
Temporary point-to-point video links	Temporary link between two points (e.g. part of a link between an OB site and a studio or network terminating point), used for carrying broadcast quality video/audio signals. Link terminals are mounted on tripods, temporary platforms, purpose built vehicles or hydraulic hoists. Two-way links are often required.

Some or all of the PMSE elements described above are in the form of a digital transport stream which can include a number and combination of video, audio, data and metadata elementary streams.

A variety of different modulation schemes are used, with different parameters chosen to suit the particular application and link quality. The following technologies, generally used for television broadcast distribution, are in common use also for video PMSE equipment:

- DVB-T      DVB-T2      LMS-T      RUBY      ISDB-T      DVB-S2

Most cordless camera links and mobile video links use Coded Orthogonal Frequency Division Multiplexing (COFDM) modulation. OFDM aims to compensate for the effects of multi-path propagation, and coding can reduce the effects of shadowing in non-line-of-sight transmission conditions. Most broadcasters and facility providers worldwide are currently using DVB-T although many vendors are now offering DVB-T2 with the improved performance this provides. There are also proprietary modulation schemes e.g. LMS-T (which incorporates most of the benefits of DVB-T2, plus a few additional ones) and RUBY (which is designed for more difficult obstructed paths, e.g. where line-of-sight transmission cannot be maintained).

DVB-S2 is used for point-to-point links, air-to-ground mobile video links from aircraft, and for Sat-coms, where line-of-sight transmission can be maintained at all times, since it provides capacity advantages over the COFDM systems.

Diversity reception using Maximum Ratio Combining (MRC) can be combined with COFDM and improves the performance of the receiver on non-line-of-sight transmission paths.





For the purposes of carrying out sharing and compatibility studies, these types of link can be reduced to four basic categories, as shown in Table 3.

**Table 3: Categories of PMSE video links for spectrum study purposes**

Type of link	Definition
Cordless camera link	Handheld or otherwise mounted camera with integrated or Clip-on transmitter, power pack and antenna for carrying broadcast-quality video together with sound signals over short-ranges (line-of-sight and non-line-of-sight).
Portable video link	Small transmitter, for deployment over greater ranges, typically up to 2 km
Mobile video link	Video transmission system employing radio transmitter and receivers mounted in/on motorcycles, racing motorbikes, pedal cycles, cars, racing cars, boats, helicopters, airships or other aircraft (includes repeaters and relays). One or both link terminals may be used while moving.
Temporary point-to-point video links	Temporary link between two points (e.g. part of a link between an OB site and a studio or network terminating point), used for carrying broadcast quality video/audio signals. Link terminals are mounted on tripods, temporary platforms, purpose built vehicles or hydraulic hoists. Two-way links are often required.

### 3 PMSE WIRELESS VIDEO LINK CHARACTERISTICS TO BE USED IN SHARING AND COMPATIBILITY STUDIES

Spectrum for video PMSE applications is usually allocated in blocks of 10 MHz. The parameters in the following tables are based on DVB-T technology for a nominal occupied bandwidth of 8 MHz (where the signal bandwidth is 7.86 MHz). The given C/N, or respectively C/(I+N) values are required for a QEF transmission (BER  $\leq 1E-11$  after error correction).

Details of the spectrum emission mask for Wireless Video Links (WVL) can be found in ETSI EN 302 064 [2].

#### 3.1 CORDLESS CAMERA LINK

These are handheld cameras with integrated transmitter, power pack and antenna. Normally they are used by a cameraman to send a video link to an OB vehicle at short distance. The emitted power is therefore lower than in other cases.

Figure 1 below depicts the situation.

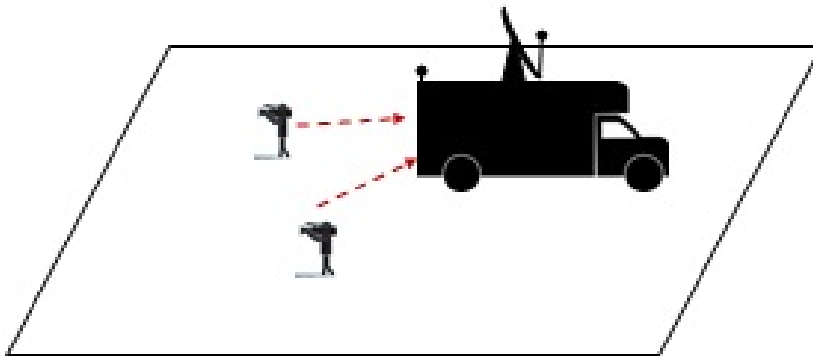

**Figure 1: Cordless camera link**

**Table 4: Cordless camera link characteristics**

Cordless camera link characteristics	Parameter values		Unit	Notes
Channel bandwidth	10		MHz	
Occupied bandwidth	8		MHz	
Frequency band	2 to 8		GHz	
Height configurations	Tx height	Rx height		
CCL-1	2	2	m	
CCL-2	2	20	m	
<b>Receiver</b>				
Receiver Typical Antenna Gain	3		dBi	ANNEX 1:, Figure 8
Receiver Maximum Antenna Gain	13		dBi	ANNEX 1:, Figure 9 or Figure 10
Receiver Noise Figure	4		dB	
C/N	9		dB	
I/N	-10 or -6 (Note 1)		dB	
Adjacent Channel Selectivity	30		dB	
Rx threshold	-92		dBm	
<b>Transmitter</b>				
Transmitter output Power	20		dBm	
Transmitter Spurious emissions	see ETSI EN 302 064		dBm/MHz	
Transmitter Adjacent Channel Leakage Ratio (relative to maximum Tx power)	see ETSI EN 302 064		dB	
Transmitter Typical Antenna Gain	0		dBi	ANNEX 1:, Figure 6
Transmitter Maximum Antenna Gain	3		dBi	ANNEX 1:, Figure 7

Note 1: see Recommendation ITU-R F.1777 [5] and Recommendation ITU-R M.1824 [6] for further information.

### 3.2 PORTABLE VIDEO LINK

Portable links are mostly handheld cameras with a separate body worn transmitter, power pack and antenna. The emitted power is normally greater than in the case of cordless camera but lower than in the case of mobile links.

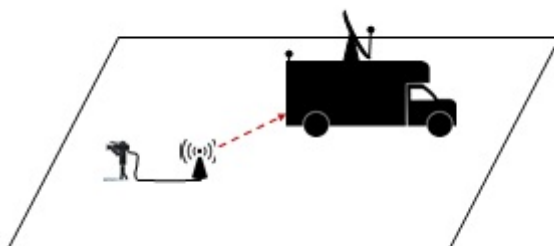

**Figure 2: Portable video link**

**Table 5: Portable video link characteristics**

Portable video link characteristics	Parameter values		Unit	Notes
Channel bandwidth	10		MHz	
Occupied bandwidth	8		MHz	
Frequency band	2 to 8		GHz	
Height configurations	Tx height	Rx height		
PVL-1	2	4	m	
PVL-2	2	50	m	
<b>Receiver</b>				
Receiver Typical Antenna Gain	9		dBi	ANNEX 1: Figure 15
Receiver Maximum Antenna Gain	17		dBi	ANNEX 1: Figure 13
Receiver Noise Figure	4		dB	
C/N	9		dB	
I/N	-10 or -6 (Note 1)		dB	
Adjacent Channel Selectivity	30		dB	
Rx threshold	-92		dBm	
<b>Transmitter</b>				
Transmitter output Power	33		dBm	
Transmitter Spurious emissions	see ETSI EN 302 064		dBm/MHz	
Transmitter Adjacent Channel Leakage Ratio (relative to maximum Tx power)	see ETSI EN 302 064		dB	
Transmitter Typical Antenna Gain	6		dBi	ANNEX 1:, Figure 11
Transmitter Maximum Antenna Gain	14		dBi	ANNEX 1:, Figure 12

Note 1: see Recommendation ITU-R F.1777 [5] and Recommendation ITU-R M.1824 [6] for further information.

For portable links high gain antennas are not usually used on both the transmit and receive sides of the same link. Portable links will typically use a low gain omnidirectional antenna on the transmitter and a high gain directional antenna on the receiver and this configuration should be used for sharing and compatibility studies.

### 3.3 MOBILE VIDEO LINK

These are camera links where, for the uplink, the transmitter is on a vehicle, typically on a motorcycle, and the receiver is on a helicopter.

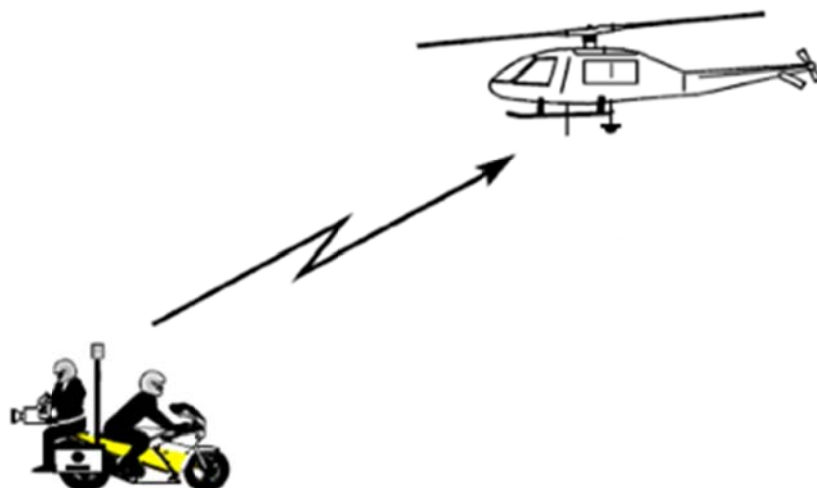

**Figure 3: Mobile video up-link**

**Table 6: Mobile video up-link characteristics**

Mobile video link characteristics	Parameter values		Unit	Notes
Channel bandwidth	10		MHz	
Occupied bandwidth	8		MHz	
Frequency band	2 to 3.5		GHz	
Height configurations	Tx-height	Rx-height		
MVL-1	2	300	m	
<b>Receiver</b>				
Receiver Typical Antenna Gain	3		dBi	ANNEX 1:, Figure 8
Receiver Maximum Antenna Gain	9		dBi	ANNEX 1:, Figure 15
Receiver Noise Figure	4		dB	
C/N	9		dB	
I/N	-10 or -6 (Note 1)		dB	
Adjacent Channel Selectivity	30		dB	
Rx threshold	-92		dBm	
<b>Transmitter</b>				
Transmitter output Power	30		dBm	
Transmitter Spurious emissions	see ETSI EN 302 064		dBm/MHz	
Transmitter Adjacent Channel Leakage Ratio (relative to maximum Tx power)	see ETSI EN 302 064		dB	
Transmitter Typical Antenna Gain	3		dBi	ANNEX 1:, Figure 8
Transmitter Maximum Antenna Gain	6		dBi	ANNEX 1:, Figure 11

Note 1: see Recommendation ITU-R F.1777 [5] and Recommendation ITU-R M.1824 [6] for further information.

These are camera links where, for the downlink, the transmitter is on a helicopter and the receiver is on a platform or on the ground.

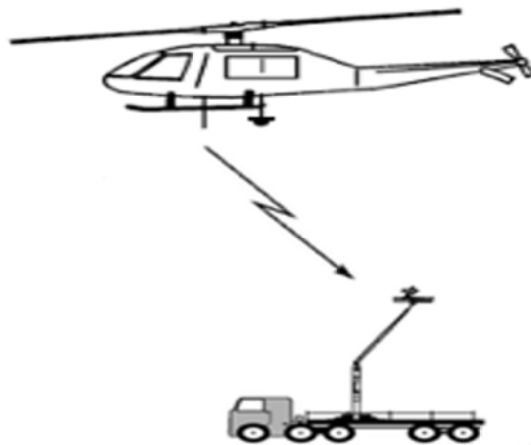

Figure 4: Mobile video down-link

Table 7: Mobile video down-link characteristics

Mobile video link characteristics	Parameter values		Unit	Notes
Channel bandwidth	10		MHz	
Occupied bandwidth	8		MHz	
Frequency band	2 to 8		GHz	
Height configurations	Tx height	Rx height		
MVL-2	300	30	m	
MVL-3	300	2	m	
<b>Receiver</b>				
Receiver Typical Antenna Gain	17		dBi	ANNEX 1: Figure 13
Receiver Maximum Antenna Gain	24		dBi	ANNEX 1:, Figure 16
Receiver Noise Figure	4		dB	
C/N	9		dB	
I/N	-10 or -6 (Note 1)		dB	
Adjacent Channel Selectivity	30		dB	
Rx threshold	-92		dBm	
<b>Transmitter</b>				
Transmitter output Power	36		dBm	
Transmitter Spurious emissions	see ETSI EN 302 064		dBm/MHz	
Transmitter Adjacent Channel Leakage Ratio (relative to maximum Tx power)	see ETSI EN 302 064		dB	
Transmitter Typical Antenna Gain	3		dBi	ANNEX 1: Figure 14
Transmitter Maximum Antenna Gain	9		dBi	ANNEX 1: Figure 15

Note 1: see Recommendation ITU-R F.1777 [5] and Recommendation ITU-R M.1824 [6] for further information.

3.4 TEMPORARY POINT-TO-POINT VIDEO LINK

These are video links, where the transmitter is on a platform, and the receiver is on tower, or vice-versa.

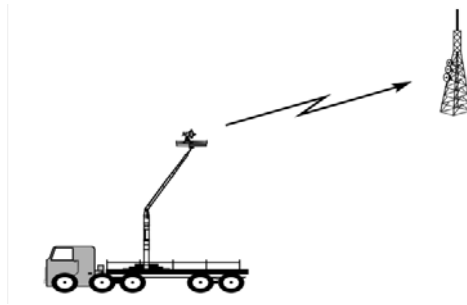

Figure 5: Temporary point-to-point video link

Table 8: Temporary point-to-point video link characteristics

Point-to-point link characteristics	Parameter values		Unit	Notes
Channel bandwidth	10		MHz	
Occupied bandwidth	8		MHz	
Frequency band	>5		GHz	
Height configurations	Tx height	Rx height		
P2P-1	20	20	m	
P2P-2	150	20	m	
P2P-3	20	150	m	
P2P-4	150	150	m	
<b>Receiver</b>				
Receiver Antenna Gain	@5 GHz 27		dBi	ANNEX 1:, Figure 17
	@7 GHz 30		dBi	
	@10 GHz 34		dBi	ANNEX 1: Figure 18
Receiver Noise Figure	5		dB	
C/N	20		dB	
I/N	-10 or -6		dB	
Adjacent Channel Selectivity	30		dB	
Rx threshold	-80		dBm	
<b>Transmitter</b>				
Transmitter output Power	33		dBm	
Transmitter Spurious emissions	see ETSI EN 302 064		dBm	
Transmitter Adjacent Channel Leakage Ratio (relative to maximum Tx power)	see ETSI EN 302 064		dB	
Transmitter Antenna Gain	@5 GHz 27		dBi	ANNEX 1:, Figure 17
	@7 GHz 30		dBi	
	@10 GHz 34		dBi	ANNEX 1:, Figure 18

Note 1: see Recommendation ITU-R F.1777 [5] and Recommendation ITU-R M.1824 [6] for further information.

## 4 CONCLUSIONS

There are a wide range of video PMSE applications and many further operational scenarios. However, for the purposes of sharing and compatibility studies, these cases have been reduced to 11 combinations of parameters based on applications and height configurations. In order to determine the use-cases that may be permitted, each of these 11 combinations should be used in studies, except for studies for spectrum below 5 GHz which do not need to include the four combinations related to temporary point-to-point links.



**ANNEX 1: INDICATIVE ANTENNA PATTERNS**

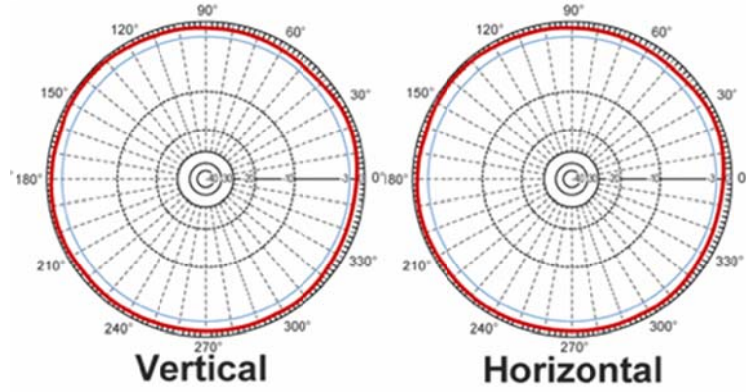

**Figure 6: 0 dBi isotropic TX antenna**

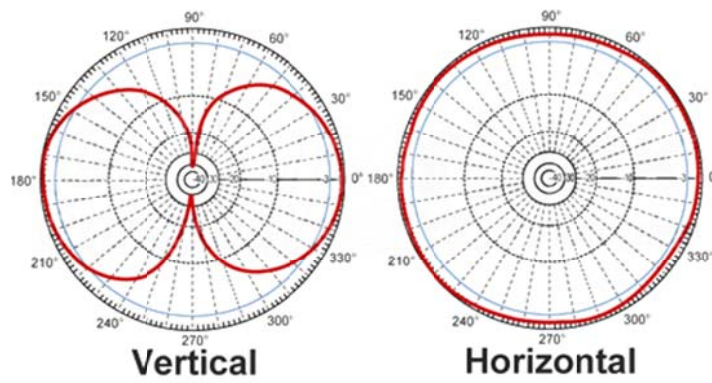

**Figure 7: 3 dBi omni directional TX antenna**

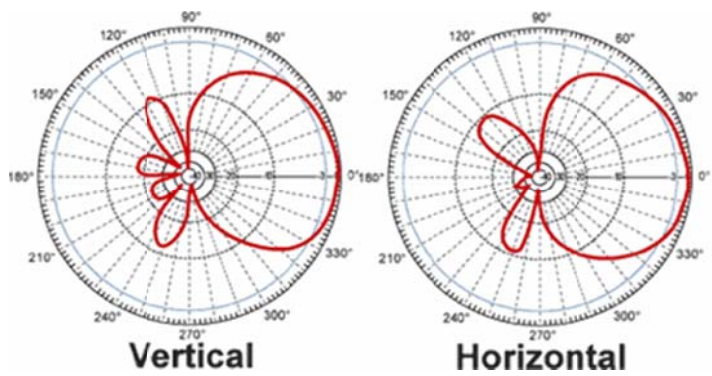

**Figure 8: 3 dBi directional Rx antenna**

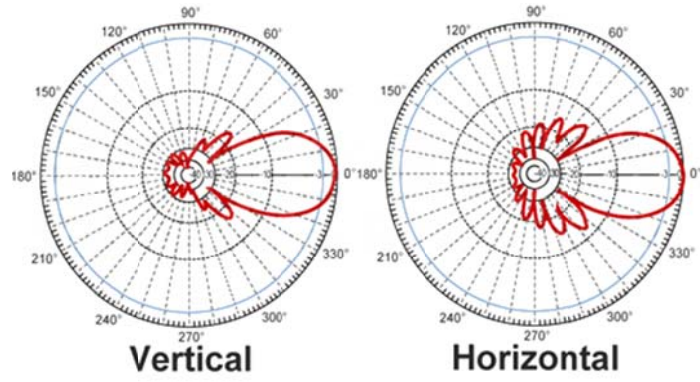

Figure 9: 13 dBi directional Rx antenna

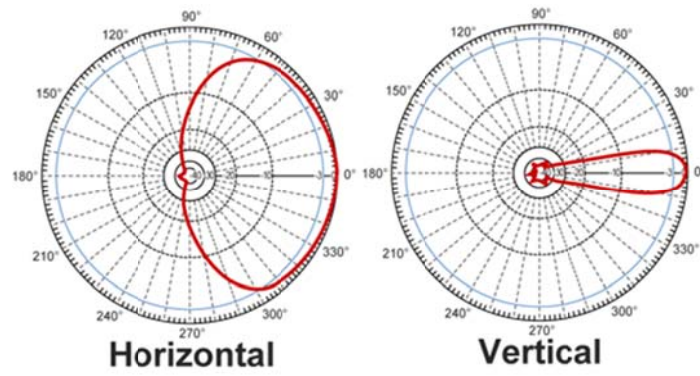

Figure 10: 13 dBi directional Rx sector antenna

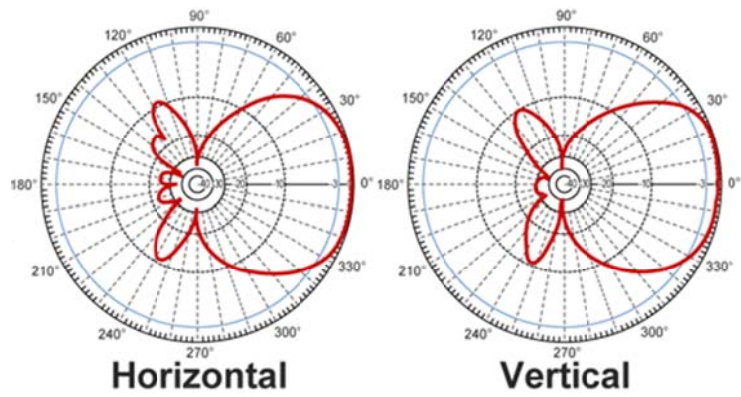

Figure 11: 6 dBi directional Tx antenna

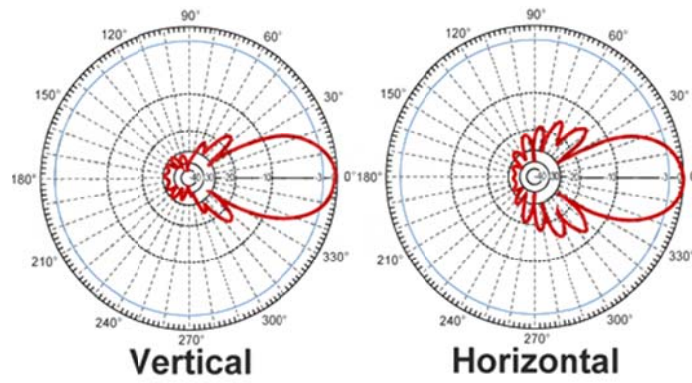

Figure 12: 14 dBi directional Tx antenna

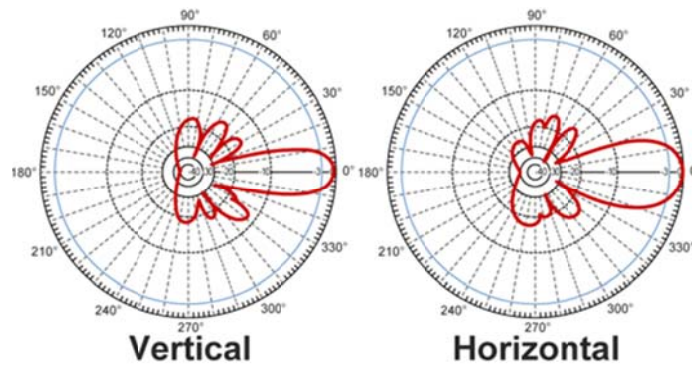

Figure 13: 17 dBi directional Rx antenna

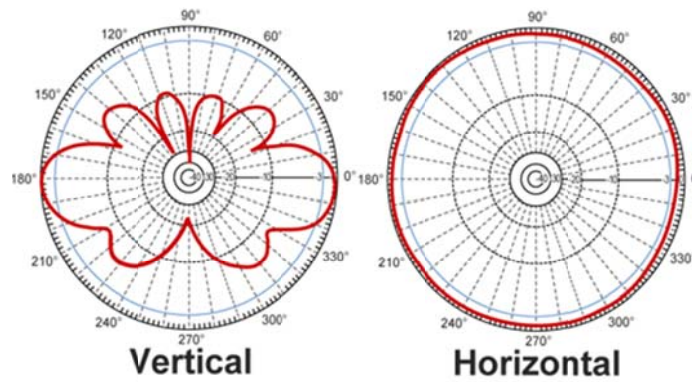

Figure 14: 3 dBi omni directional Tx antenna

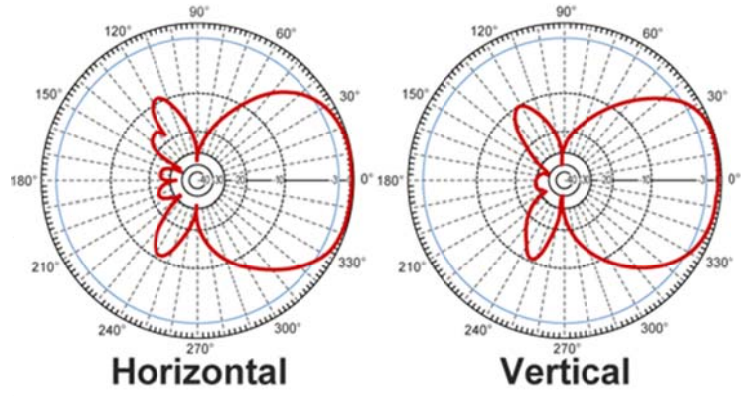

Figure 15: 9 dBi directional auto-tracking Tx antenna

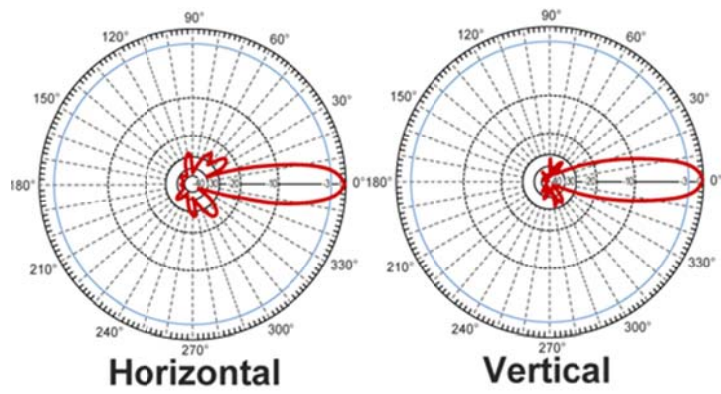

Figure 16: 24 dBi directional Rx antenna

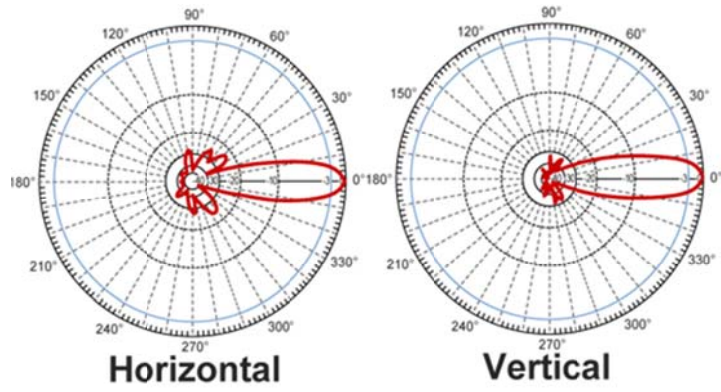

Figure 17: 24 dBi directional Tx/Rx antenna

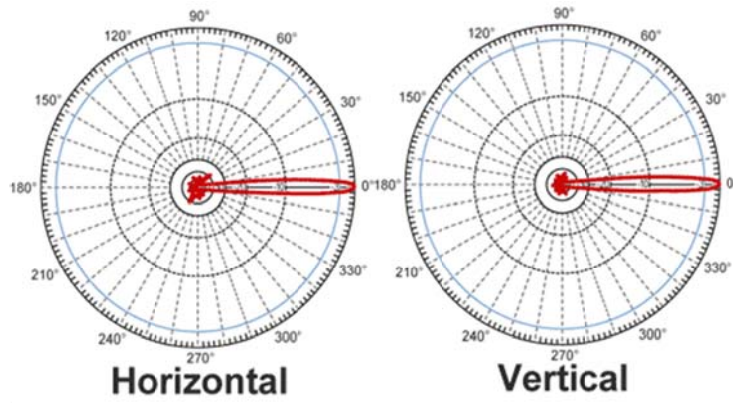

Figure 18: 34 dBi directional Tx/Rx antenna

## ANNEX 2: LIST OF REFERENCES

- [1] ECC Report 204: Spectrum use and future requirements for PMSE
- [2] ETSI EN 302 064: Electromagnetic compatibility and Radio spectrum Matters (ERM); Wireless Video Links (WVL) operating in the 1,3 GHz to 50 GHz frequency band
- [3] Recommendation ITU-T H.264: Advanced video coding for generic audiovisual services
- [4] Recommendation ITU-T H.265: High efficiency video coding
- [5] Recommendation ITU-R F.1777: System characteristics of television outside broadcast, electronic news gathering and electronic field production in the fixed service for use in sharing studies
- [6] Recommendation ITU-R M.1824: System characteristics of television outside broadcast, electronic news gathering and electronic field production in the mobile service for use in sharing studies